

h3+

Moulded Case Circuit Breakers

Reliable protection against overloads and short circuits: h3+ moulded case circuit breakers provide additional safety for electrical installations in commercial buildings, through the advanced features and functionality of electronic trip options.

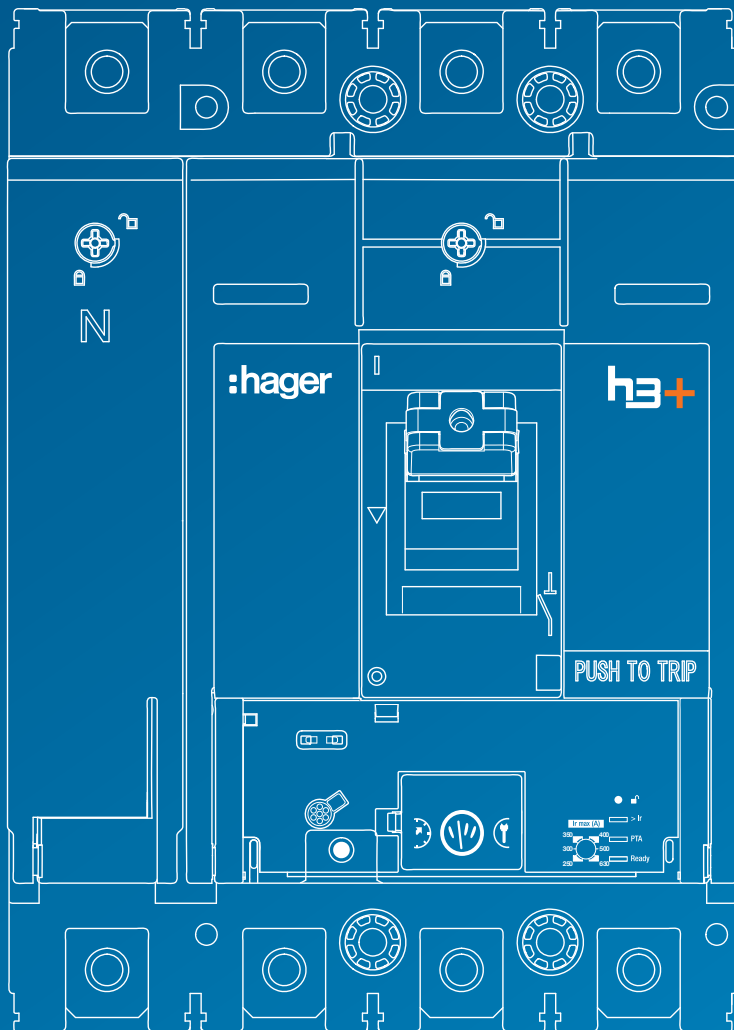

Disclaimer:

Whilst every effort has been made to ensure the reliability of the information is correct at time of publication, Hager cannot guarantee the accuracy of all information contained herein. Corrections and amendments, once verified, will be included in future editions

Index

Page

01 h3+ presentation	5
Range overview, h3+ communication system, h3+ Energy highlights, General characteristics	
02 List of references	17
P160 MCCBs, P250 MCCBs, P630 MCCBs, RCD add-on blocks, Switch disconnectors, Connections, Connections, Electronic devices and accessories, Auxiliaries, Handles and locking kits, Mechanical interlocking, Motor operators, Plug-in and withdrawable systems	
03 h3+ electromechanical range	41
TM and MAG (ICB) trip units	
04 h3+ electronic range	45
Electronic trip units, Communication devices	
05 Switch-disconnector range	65
Presentation	
06 Accessories	69
Overview, Earth leakage protection, Connection accessories, Insulation accessories, Auxiliaries, Mounting types, Handles and motor operators, Locking and sealing accessories	
07 Installation and operating recommendations	101
Installation and operating conditions 2, Safety clearances and minimum distances, Power loss	
08 Dimensions and connections	111
Circuit breakers and RCD add-on block, Circuit breakers plug-in, Circuit breakers withdrawables, Handles and motor operators, Front panel cut-outs, Power connections, Panel display	
09 Technical Characteristics	147
Time Current Characteristics, Earth Fault Loop Impedance Data, Let-Through Energy, Peak Current Cut Off Characteristics, Electronic Trip Versions	
10 Glossary	157

h3+ presentation

List of references

h3+ electromechanical range

h3+ electronic range

Switch-disconnector range

Accessories

Installation and operating recommendations

Dimensions and connections

Technical Characteristics

Glossary

h3+ presentation

	Page
01 Range overview	6
02 h3+ communication system	10
03 h3+ Energy highlights	11
04 General characteristics	12

The new generation of Hager Moulded Case Circuit Breakers h3+ ensures reliable protection against overloads and short circuits, combined with accurate integrated energy monitoring for all low voltage distribution systems. With a compact frame size, available from 25 to 630A in 3 and 4 poles & 16 to 125A in 1 Pole, h3+ offers high protection performance with a breaking capacity up to 110 kA.

h3+ MCCBs, available with either a built-in thermal-magnetic trip unit or electronic trip unit, offer flexible protection settings to ease discrimination in all electrical distribution installations.

Hager is meeting the latest energy efficiency standards by introducing new features to its offer of Moulded Case Circuit Breakers.

Users will benefit from a class 1 energy monitoring and communication system compatible with Modbus RTU protocol, that will allow them to configure protections parameters, monitor energy consumptions and manage alarms.

Special attention has been given to ergonomics in order to facilitate the integration of h3+ MCCB in electrical LV switch boards. Different methods of mounting are proposed along with different types of connections to increase the flexibility of installation.



h3+ P160 3P Energy



h3+ P250 3P Energy



h3+ P630 Energy 3P Energy

h3+ Moulded Case Circuit Breaker at a glance

The h3+ range of MCCB can be briefly described as follows:

- Three frame sizes: P160, P250 and P630
- Rated current from 25 A to 630 A
- Icu and Ics up to 110 kA (415 V~)
- Available in 3 and 4 poles
- Rated nominal voltage Ue up to 690 V~
- Thermal-Magnetic, Magnetic and Electronic Trip Units
- Wide range of accessories

Energy electronic trip unit with:

- Embedded display
- Measurement features (I, U, P, E, PF, THD...)
- Class 1 accuracy on energy measurements according to IEC 61557-12
- Alarm management and event histories
- Output contacts (PTA, OAC)
- Modbus RTU communication for remote monitoring and control
- MIP Connector
- Communication accessories (Panel display, COM module...)

h3+ Switch-disconnectors

- P160 ratings: 125 A, 160 A
- P250 ratings: 200 A, 250 A
- P630 ratings: 400 A, 630 A

	H	N	M	E	P	TM	MAG (CBI)	LSnI	LSI	LSIG	Energy
	25 kA	40 kA	50 kA	70 kA	110 kA						
P160	X	X	X	X		25 to 160 A		40 to 160 A		-	40 to 160 A
P250	X	X	X	X		50 to 250 A	100 to 250 A	40 to 250 A			
P630		X	X	X	X	-			250 to 630 A		

Range overview

Switch-disconnector



Switch

Magnetic



MAG (CBI)

Thermal-magnetic



TM adj

Accessories

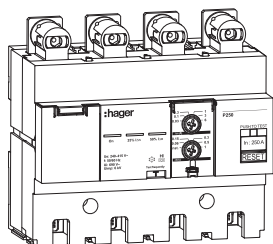

Earth leakage

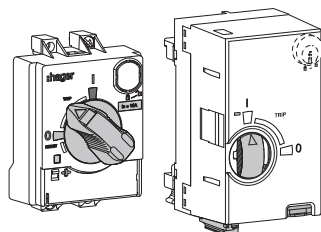

Handles and motor operator

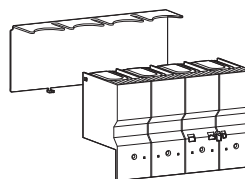

Insulation

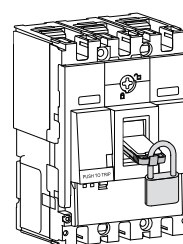

Locking and sealing

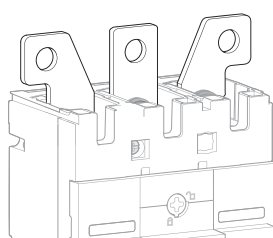

Connections

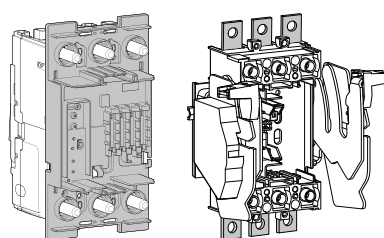

Mounting types

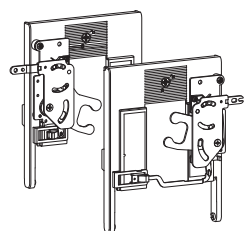

Interlocking accessories

Electronic Range



LSn1



LSI



LSIG



Energy

Communication devices

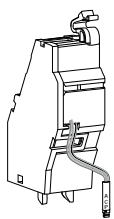

AX/AL Energy

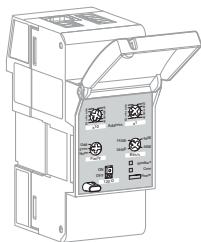

**Modbus
Modules**

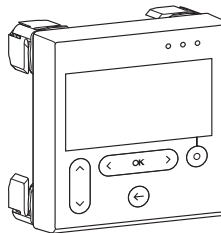

Display

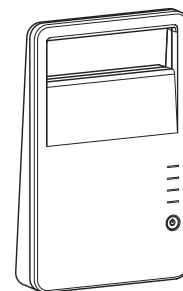

Configuration tool

Auxiliaries

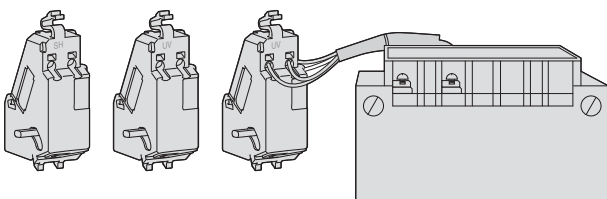

Shunt trip and under voltage releases

h3+ communication system



h3+ communication schematic

The h3+ communication system allows the establishment of local and remote communication between the Energy MCCB and its surroundings.

Local monitoring is done using either the embedded display or the panel display on which the user can see all the measurements collected by the power meter integrated in the Energy MCCB. As for the local controlling, it can be done using either the OAC output contact or the PTA output contact. In addition to that, a dedicated port exists to connect the MCCB locally to the h3+ Configuration tool that will allow to do the configuration and the test of the MCCB along with a visualisation of all measurements collected by the MCCB itself.

Remote monitoring can be done by connecting the MCCB Energy via the Modbus COM Module to any Modbus network with Modbus RTU protocol.

The h3+ communication system contributes in increasing energy efficiency, improving electrical power quality, maintaining the continuity of supply and alerting the user in case of any malfunction.

Overview of the main functionalities provided by the h3+ communication system:

- Checking MCCB status:
On/Off position, trip indication and fault-trip indication
- Visualising measurements:
mainly I, U, f, P, E, and THD.
- Configuration of the protection settings, measurement parameters and custom alarms.
- Managing alarms by the means of embedded output contacts: PTA and OAC.
- Operating commands:
open, close, and trip by the means of accessories such as the motor operator and the Shunt trip/Undervoltage releases.
- Operating data:
settings, alarms, events and maintenance indicators.

The Maintenance Interface Port (MIP) located at the front of the electronic trip units is used to interface the MCCB to the h3+ Configuration tool.

This tool is suitable for an expert use of the h3+ electronic trip units. It provides functions such as configuration, monitoring and test.

h3+ Energy highlights

h3+ presentation



Fast opening 1/4 turn screw
Eases the access to auxiliary and communication cavities.



Integrated padlocking facility
Up to 4 mm Ø padlocks handled without accessory tool.



Auxiliary indication windows
Presence of auxiliaries easily visible.



Integrated PTA output contact
Output contact dedicated to the overload prealarm.



Integrated OAC output contact
Output contact assignable to a custom alarm with access behind the front cover.



h3+ Configuration tool

Wireless access to the electronic trip units for configuration, test and diagnostic.



High contrast display

Display on h3+ Energy MCCB benefits from OLED technology and can be oriented in any direction to match the MCCB orientation..

Information on product

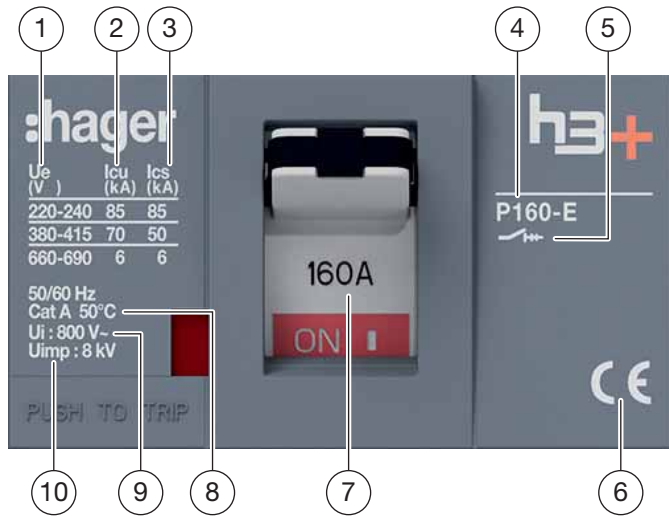

Standardised characteristics on the product

- ① U_e: Operational voltage
- ② I_{cu}: Ultimate breaking capacity per rated operational voltage U_e
- ③ I_{cs}: Service breaking capacity per rated operational voltage U_e
- ④ Circuit breaker type, frame size and breaking capacity classification
- ⑤ Symbol for Circuit Breaker suitable for isolation
- ⑥ Approvals and Standard Compliance
- ⑦ Nominal rating
- ⑧ Calibration temperature
- ⑨ U_i: Rated insulation voltage
- ⑩ U_{imp}: Rated impulse withstand voltage

Breaking capacity classification:

	I _{cu} (380 – 415 V~)
H	25 kA
N	40 kA
M	50 kA
E	70 kA
P	110 kA

Compliance with standards

h3+ circuit breakers and auxiliaries comply to the following Standards:

International standards:

- IEC 60947-1: general rules
- IEC 60947-2: circuit breakers
- IEC 60947-3: switch-disconnectors
- IEC 60947-5-1: control circuit devices and switching elements

European standards

- EN 60947-1: General rules
- EN 60947-2: Circuit breakers
- EN 60947-3: Switch disconnectors
- EN 60947-5-1: Control circuit devices and switching elements

National standards:

- China CCC, GB/T140248.2
- China CCC, GB/T140248.3
- China CCC, GB/T140248.1

Pollution degree

h3+ circuit breakers are certified for operation in pollution degree 3 environments as defined by IEC standards 60947-1.

Ambient temperature

h3+ P160, P250 and P630 circuit breakers can be used from -25 °C to 70 °C.

For ambient temperatures greater than 50 °C, TM devices must be derated.

Electronic circuit breakers must be derated when the ambient temperature is greater than 50 °C.

Please refer to chapter “Installation and operating recommendations” on page 101.

h3+ P160, P250 and P630 circuit breakers should be put into service under normal ambient, operating temperature conditions.

The acceptable storage temperature range in the original packing is from -35 °C to 70 °C.

Electromagnetic disturbances

h3+ circuit breakers are protected against:

- Overvoltage caused by circuit switching,
- Overvoltage caused by atmospheric disturbances or a distribution-system outage (e.g. failure of a lighting system),
- Devices emitting radio waves (walkie-talkies, radar, etc.),
- Electrostatic discharges produced directly by users.

Immunity levels for h3+ comply with:

- IEC/EN 60947-2: Low-voltage switchgear and controlgear, part 2: Circuit breakers.
- Annex F 4.1: Harmonic of current, Annex F 4.7: Deep current.
- Annex B: Immunity tests for residual current protection
- IEC/EN 61000-4-2: Electrostatic-discharge immunity tests.
- IEC/EN 61000-4-3: Radiated, radio-frequency, electromagnetic-field immunity tests.
- IEC/EN 61000-4-4: Electrical fast transient/burst immunity tests.
- IEC/EN 61000-4-5: Surge immunity tests.
- IEC/EN 61000-4-6: Immunity tests for conducted disturbances induced by radio-frequency fields.
- CISPR 11: Limits and methods of measurement of electromagnetic disturbance characteristics of industrial, scientific and medical (ISM) radio-frequency equipment.

Over-current Discrimination (Selectivity)

h3+ circuit breakers provide all characteristics required to apply over-current protective co-ordination as defined in the IEC 60947-1.

Depending on the type of two or more h3+ MCCBs in series, total or partial discrimination (selectivity) can be achieved.

Total over-current discrimination (Total selectivity):

In case of two MCCBs in series, the circuit breaker at the downstream level ensures the protection without tripping the circuit breaker at the upstream level.

Partial over-current discrimination (Partial selectivity):

In case of two MCCBs in series, the MCCB at the downstream level ensures the protection up to a given value of over-current level without tripping the MCCB at the upstream level.

Discrimination tables between different associations of protection devices (ACB-MCCB-MCB) are given in a separate document.

Cascading

Cascading or back-up protection means that the current limiting capacity of a MCCB makes it possible to install downstream circuit breakers that have lower Icu levels.

The different values of short-circuit currents between different associations of protection devices (ACB-MCCB-MCB) are given in cascading tables that are published in a separate document.

Suitable for isolation with positive contact indication

All h3+ P160, P250 and P630 circuit breakers are suitable for isolation as defined in IEC 60947-2 standard :

- The isolation position corresponds to the O (OFF) position.
- The operating handle does not indicate the OFF position unless contacts are open and respect the insulation distances.
- Padlocks cannot be installed unless contacts are open and the operating handle is in a stable position. Installation of a rotary handle does not alter the reliability of the position-indication system.

The isolation function is certified by tests guaranteeing:

- Mechanical reliability of the position indication system,
- Absence of leakage currents,
- Capacity to withstand overvoltage between upstream and downstream connections.

The tripped position does not ensure isolation with positive contact indication; only the OFF position guarantees isolation.

Vibrations

h3+ P160, P250 and P630 circuit breakers withstand mechanical vibrations.

h3+ circuit breakers comply to IEC 60068-2-52:

- 2.0 to 13.2 Hz and amplitude ± 1 mm.
- 13.2 to 100 Hz acceleration ± 0.7 G.
- Resonance frequency (± 1 mm/ ± 0.7 g during 90 min.

Excessive vibration may cause false tripping and/or damage to connections and/or mechanical parts.

Circuit breakers	P160	P250	P630
Number of poles	3, 4	3, 4	3, 4

General characteristics

Rated current at 50 °C	In (A)	160	250	630
Current rated range	(A)	25 - 160 (Thermal Magnetic), 40 - 160 (Electronic)	50 - 250 (Thermal Magnetic), 40 - 250 (Electronic)	250 - 630
Operational voltage, (AC)	Ue (V)	220 - 690	220 - 690	220 - 690
Frequency	f (Hz)	50/60	50/60	50/60
Rated insulation voltage	Ui (V)	800	800	800
Rated impulse withstand voltage	Uimp (kV)	8	8	8
Suitability for isolation		yes	yes	yes
Utilisation category (IEC60947-2)		A	A	B ≤400A A > 400A
Pollution degree		3	3	3
Breaking capacity level		H N M E	H N M E	N M E P

Rated ultimate short-circuit breaking capacity, (Icu)

(AC) 50/60 Hz 220/240 V	Icu (kA)	35	50	65	85	35	50	65	85	70	85	100	125
(AC) 50/60 Hz 380/415 V	Icu (kA)	25	40	50	70	25	40	50	70	40	50	70	110
(AC) 50/60 Hz 660/690 V	Icu (kA)	6	6	6	6	6	6	6	6	7	12	12	12

Rated service short-circuit breaking capacity, (Ics)

(AC) 50/60 Hz 220/240 V	Ics (kA)	35	50	65	85	35	50	65	85	70	85	100	125
(AC) 50/60 Hz 380/415 V	Ics (kA)	25	40	50	50	25	40	50	50	40	50	70	110
(AC) 50/60 Hz 660/690 V	Ics (kA)	6	6	6	6	6	6	6	6	7	12	12	12
Mechanical endurance in number of operations (IEC 60947-2)		40 000				40 000				30 000			
Electrical endurance in number of cycles at 440 V~ (IEC 60947-2)		10 000				10 000				6 000 ≤400A 4 000 > 400A			

Environment

Operating temperature		-25 °C to +70 °C	-25 °C to +70 °C	-25 °C to +70 °C
Storage temperature		-35 °C to +70 °C	-35 °C to +70 °C	-35 °C to +70 °C
Tropicalisation		95 % HR at 55 °C	95 % HR at 55 °C	95 % HR at 55 °C
Altitude	(m)	≤ 2000	≤ 2000	≤ 2000

Terminations

Pitch	(mm)	30	35	45
Maximal terminal torque	(Nm)	6	12	18
Terminal width	(mm)	21	25	32

Dimensions

Height	(mm)	130	165	260
Width	3P (mm)	90	105	140
	4P (mm)	120	140	185
Depth	(mm)	97	97	150
Weight	3P (kg)	1.1	1.5	5.8
	4P (kg)	1.4	1.9	7.6

Circuit breakers	P160	P250	P630
Protection	yes	yes	yes
MAG (CBI): li adjustable	yes	yes	no
TM (Thermal magnetic): Ir adjustable, li adjustable, neutral protection adjustable on 4P	yes	yes	no
LSnI: Ir adjustable, tr fixed, lsd adjustable, tsd fixed, li fixed, neutral protection adjustable on 4P	yes	yes	no
LSI: Ir & tr adjustable, lsd & tsd adjustable, li adjustable, neutral protection adjustable on 4P	yes	yes	yes
LSIG: Ir & tr adjustable, lsd & tsd adjustable, li adjustable, lg & tg fixed, neutral protection adjustable on 4P	no	yes	yes
Energy: Ir & tr adjustable, lsd & tsd adjustable, li adjustable, lg & tg adjustable, neutral protection adjustable on 4P	yes	yes	yes
Earth leakage protection with add-on block	no	yes	yes
Earth leakage protection with relay	yes	yes	yes

Measurement and advanced functions

Trip unit version	LSnI	LSI	Energy	LSnI	LSI	LSIG	Energy	LSI	LSIG	Energy
Embedded display of measurements and trip causes	no	no	yes	no	no	no	yes	no	no	yes
PTA output contact	no	yes	yes	no	yes	yes	yes	yes	yes	yes
OAC output contact	no	no	yes	no	no	no	yes	no	no	yes
MIP connector for Configuration tool	yes	yes	yes	yes	yes	yes	yes	yes	yes	yes

Options

Panel display	no	no	yes	no	no	no	yes	no	no	yes
Communication module	no	no	yes	no	no	no	yes	no	no	yes
MCCB status, operation and trip counters via AX/AL Energy	no	no	yes	no	no	no	yes	no	no	yes
Configuration tool	yes*	yes*	yes	yes*	yes*	yes*	yes	yes*	yes*	yes

(*) limited to certain functions.

List of references

	Page
01 P160 MCCBs	18
02 P250 MCCBs	23
03 P630 MCCBs	27
04 RCD add-on blocks	29
05 Switch disconnectors	30
06 Connections	31
07 Electronic devices and accessories	33
08 Auxiliaries	35
09 Handles and locking kits	36
10 Mechanical interlocking	37
11 Motor operators	38
12 Plug-in and withdrawable systems	39

h3+ P160 - TM adjustable with cable terminals



HES161DC

Icu / Ics 400 - 415 V~	In (A)	3 poles	4 poles N: 0-100 %	1 Pole Icu / Ics 25kA / 20kA
25 kA / 25 kA	16	-	-	HHS014EC
	20	-	-	HHS018EC
	25	HHS025DC	HHS026DC	HHS023EC
	32	-	-	HHS030EC
	40	HHS040DC	HHS041DC	HHS038EC
	50	-	-	HHS048EC
	63	HHS063DC	HHS064DC	HHS061EC
	80	HHS080DC	HHS081DC	HHS078EC
	100	HHS100DC	HHS101DC	HHS098EC
	125	HHS125DC	HHS126DC	HHS123EC
	160	HHS160DC	HHS161DC	-
40 kA / 40 kA	25	HNS025DC	HNS026DC	-
	40	HNS040DC	HNS041DC	-
	63	HNS063DC	HNS064DC	-
	80	HNS080DC	HNS081DC	-
	100	HNS100DC	HNS101DC	-
	125	HNS125DC	HNS126DC	-
	160	HNS160DC	HNS161DC	-
50 kA / 50 kA	25	HMS025DC	HMS026DC	-
	40	HMS040DC	HMS041DC	-
	63	HMS063DC	HMS064DC	-
	80	HMS080DC	HMS081DC	-
	100	HMS100DC	HMS101DC	-
	125	HMS125DC	HMS126DC	-
	160	HMS160DC	HMS161DC	-
70 kA / 50 kA	25	HES025DC	HES026DC	-
	40	HES040DC	HES041DC	-
	63	HES063DC	HES064DC	-
	80	HES080DC	HES081DC	-
	100	HES100DC	HES101DC	-
	125	HES125DC	HES126DC	-
	160	HES160DC	HES161DC	-

h3+ P160 - MAG with cable terminals



HES161BC

Icu / Ics 400 - 415 V~	In (A)	3 poles	4 poles
25 kA / 25 kA	25	HHS025BC	HHS026BC
	40	HHS040BC	HHS041BC
	50	HHS050BC	HHS051BC
	63	HHS063BC	HHS064BC
	80	HHS080BC	HHS081BC
	100	HHS100BC	HHS101BC
	125	HHS125BC	HHS126BC
	160	HHS160BC	HHS161BC
40 kA / 40 kA	25	HNS025BC	HNS026BC
	40	HNS040BC	HNS041BC
	50	HNS050BC	HNS051BC
	63	HNS063BC	HNS064BC
	80	HNS080BC	HNS081BC
	100	HNS100BC	HNS101BC
	125	HNS125BC	HNS126BC
	160	HNS160BC	HNS161BC
50 kA / 50 kA	25	HMS025BC	HMS026BC
	40	HMS040BC	HMS041BC
	50	HMS050BC	HMS051BC
	63	HMS063BC	HMS064BC
	80	HMS080BC	HMS081BC
	100	HMS100BC	HMS101BC
	125	HMS125BC	HMS126BC
	160	HMS160BC	HMS161BC
70 kA / 50 kA	25	HES025BC	HES026BC
	40	HES040BC	HES041BC
	50	HES050BC	HES051BC
	63	HES063BC	HES064BC
	80	HES080BC	HES081BC
	100	HES100BC	HES101BC
	125	HES125BC	HES126BC
	160	HES160BC	HES161BC

List of references

h3+ P160 - LSnl with cable terminals



HES161GC

Icu / Ics 400 - 415 V~	In (A)	3 poles	4 poles N: 0-50-100%
25 kA / 25 kA	40	HHS040GC	HHS041GC
	100	HHS100GC	HHS101GC
	160	HHS160GC	HHS161GC
40 kA / 40 kA	40	HNS040GC	HNS041GC
	100	HNS100GC	HNS101GC
	160	HNS160GC	HNS161GC
50 kA / 50 kA	40	HMS040GC	HMS041GC
	100	HMS100GC	HMS101GC
	160	HMS160GC	HMS161GC
70 kA / 50 kA	40	HES040GC	HES041GC
	100	HES100GC	HES101GC
	160	HES160GC	HES161GC

h3+ P160 - LSI with cable terminals



HES161JC

Icu / Ics 400 - 415 V~	In (A)	3 poles	4 poles N: 0-50-100%
25 kA / 25 kA	40	HHS040JC	HHS041JC
	100	HHS100JC	HHS101JC
	160	HHS160JC	HHS161JC
40 kA / 40 kA	40	HNS040JC	HNS041JC
	100	HNS100JC	HNS101JC
	160	HNS160JC	HNS161JC
50 kA / 50 kA	40	HMS040JC	HMS041JC
	100	HMS100JC	HMS101JC
	160	HMS160JC	HMS161JC
70 kA / 50 kA	40	HES040JC	HES041JC
	100	HES100JC	HES101JC
	160	HES160JC	HES161JC

List of references

h3+ P160 - Energy with cable terminals



HES161NC

Icu / Ics 400 - 415 V~	In (A)	3 poles	4 poles N: 0-50-100%
25 kA / 25 kA	40	HHS040NC	HHS041NC
	100	HHS100NC	HHS101NC
	160	HHS160NC	HHS161NC
40 kA / 40 kA	40	HNS040NC	HNS041NC
	100	HNS100NC	HNS101NC
	160	HNS160NC	HNS161NC
50 kA / 50 kA	40	HMS040NC	HMS041NC
	100	HMS100NC	HMS101NC
	160	HMS160NC	HMS161NC
70 kA / 50 kA	40	HES040NC	HES041NC
	100	HES100NC	HES101NC
	160	HES160NC	HES161NC

h3+ P250 - TM adjustable with front connection



HET251DR

Icu / Ics 400 - 415 V~	In (A)	3 poles	4 poles N: 0-100 %
25 kA / 25 kA	50	HHT050DR	HHT051DR
	63	HHT063DR	HHT064DR
	100	HHT100DR	HHT101DR
	125	HHT125DR	HHT126DR
	160	HHT160DR	HHT161DR
	200	HHT200DR	HHT201DR
	250	HHT250DR	HHT251DR
40 kA / 40 kA	50	HNT050DR	HNT051DR
	63	HNT063DR	HNT064DR
	100	HNT100DR	HNT101DR
	125	HNT125DR	HNT126DR
	160	HNT160DR	HNT161DR
	200	HNT200DR	HNT201DR
	250	HNT250DR	HNT251DR
50 kA / 50 kA	50	HMT050DR	HMT051DR
	63	HMT063DR	HMT064DR
	100	HMT100DR	HMT101DR
	125	HMT125DR	HMT126DR
	160	HMT160DR	HMT161DR
	200	HMT200DR	HMT201DR
	250	HMT250DR	HMT251DR
70 kA / 50 kA	50	HET050DR	HET051DR
	63	HET063DR	HET064DR
	100	HET100DR	HET101DR
	125	HET125DR	HET126DR
	160	HET160DR	HET161DR
	200	HET200DR	HET201DR
	250	HET250DR	HET251DR

h3+ P250 - MAG with front connection



HET251BR

Icu / Ics 400 - 415 V~	In (A)	3 poles	4 poles
25 kA / 25 kA	100	HHT100BR	HHT101BR
	125	HHT125BR	HHT126BR
	160	HHT160BR	HHT161BR
	200	HHT200BR	HHT201BR
	250	HHT250BR	HHT251BR
40 kA / 40 kA	100	HNT100BR	HNT101BR
	125	HNT125BR	HNT126BR
	160	HNT160BR	HNT161BR
	200	HNT200BR	HNT201BR
	250	HNT250BR	HNT251BR
50 kA / 50 kA	100	HMT100BR	HMT101BR
	125	HMT125BR	HMT126BR
	160	HMT160BR	HMT161BR
	200	HMT200BR	HMT201BR
	250	HMT250BR	HMT251BR

h3+ P250 - LSnl with front connection



HET251GR

Icu / Ics 400 - 415 V~	In (A)	3 poles	4 poles N: 0-50-100%
25 kA / 25 kA	40	HHT040GR	HHT041GR
	100	HHT100GR	HHT101GR
	160	HHT160GR	HHT161GR
	250	HHT250GR	HHT251GR
40 kA / 40 kA	40	HNT040GR	HNT041GR
	100	HNT100GR	HNT101GR
	160	HNT160GR	HNT161GR
	250	HNT250GR	HNT251GR
50 kA / 50 kA	40	HMT040GR	HMT041GR
	100	HMT100GR	HMT101GR
	160	HMT160GR	HMT161GR
	250	HMT250GR	HMT251GR
70 kA / 50 kA	40	HET040GR	HET041GR
	100	HET100GR	HET101GR
	160	HET160GR	HET161GR
	250	HET250GR	HET251GR

h3+ P250 - LSI with front connection



HET251JR

Icu / Ics 400 - 415 V~	In (A)	3 poles		4 poles
		N: 0-50-100%		
25 kA / 25 kA	40	HHT040JR	HHT041JR	
	100	HHT100JR	HHT101JR	
	160	HHT160JR	HHT161JR	
	250	HHT250JR	HHT251JR	
40 kA / 40 kA	40	HNT040JR	HNT041JR	
	100	HNT100JR	HNT101JR	
	160	HNT160JR	HNT161JR	
	250	HNT250JR	HNT251JR	
50 kA / 50 kA	40	HMT040JR	HMT041JR	
	100	HMT100JR	HMT101JR	
	160	HMT160JR	HMT161JR	
	250	HMT250JR	HMT251JR	
70 kA / 50 kA	40	HET040JR	HET041JR	
	100	HET100JR	HET101JR	
	160	HET160JR	HET161JR	
	250	HET250JR	HET251JR	

h3+ P250 - LSIg with front connection



HET250LR

Icu / Ics 400 - 415 V~	In (A)	4 poles	
		N: 0-50-100%	
25 kA / 25 kA	40	HHT041LR	
	100	HHT101LR	
	160	HHT161LR	
	250	HHT251LR	
40 kA / 40 kA	40	HNT041LR	
	100	HNT101LR	
	160	HNT161LR	
	250	HNT251LR	
50 kA / 50 kA	40	HMT041LR	
	100	HMT101LR	
	160	HMT161LR	
	250	HMT251LR	
70 kA / 50 kA	40	HET041LR	
	100	HET101LR	
	160	HET161LR	
	250	HET251LR	

h3+ P250 - Energy with front connection



HET251NR

Icu / Ics 400 - 415 V~	In (A)	3 poles	4 poles N: 0-50-100%
25 kA / 25 kA	40	HHT040NR	HHT041NR
	100	HHT100NR	HHT101NR
	160	HHT160NR	HHT161NR
	250	HHT250NR	HHT251NR
40 kA / 40 kA	40	HNT040NR	HNT041NR
	100	HNT100NR	HNT101NR
	160	HNT160NR	HNT161NR
	250	HNT250NR	HNT251NR
50 kA / 50 kA	40	HMT040NR	HMT041NR
	100	HMT100NR	HMT101NR
	160	HMT160NR	HMT161NR
	250	HMT250NR	HMT251NR
70 kA / 50 kA	40	HET040NR	HET041NR
	100	HET100NR	HET101NR
	160	HET160NR	HET161NR
	250	HET250NR	HET251NR

h3+ P630 - LSI with front connection



HPW631JR

Icu / Ics 400 - 415 V~	In (A)	3 poles	4 poles
		N: 0-50-100%	
40 kA / 40 kA	250	HNW250JR	HNW251JR
	400	HNW400JR	HNW401JR
	630	HNW630JR	HNW631JR
50 kA / 50 kA	250	HMW250JR	HMW251JR
	400	HMW400JR	HMW401JR
	630	HMW630JR	HMW631JR
70 kA / 70 kA	250	HEW250JR	HEW251JR
	400	HEW400JR	HEW401JR
	630	HEW630JR	HEW631JR
110 kA / 110 kA	250	HPW250JR	HPW251JR
	400	HPW400JR	HPW401JR
	630	HPW630JR	HPW631JR

h3+ P630 - LSIG with front connection



HPW631LR

Icu / Ics 400 - 415 V~	In (A)	4 poles
		N: 0-50-100%
40 kA / 40 kA	250	HNW251LR
	400	HNW401LR
	630	HNW631LR
50 kA / 50 kA	250	HMW251LR
	400	HMW401LR
	630	HMW631LR
70 kA / 70 kA	250	HEW251LR
	400	HEW401LR
	630	HEW631LR
110 kA / 110 kA	250	HPW251LR
	400	HPW401LR
	630	HPW631LR

List of references

h3+ P630 - Energy with front connection



HPW631NR

Icu / Ics 400 - 415 V~	In (A)	3 poles	4 poles N: 0-50-100%
40 kA / 40 kA	250	HNW250NR	HNW251NR
	400	HNW400NR	HNW401NR
	630	HNW630NR	HNW631NR
50 kA / 50 kA	250	HMW250NR	HMW251NR
	400	HMW400NR	HMW401NR
	630	HMW630NR	HMW631NR
70 kA / 70 kA	250	HEW250NR	HEW251NR
	400	HEW400NR	HEW401NR
	630	HEW630NR	HEW631NR
110 kA / 110 kA	250	HPW250NR	HPW251NR
	400	HPW400NR	HPW401NR
	630	HPW630NR	HPW631NR

RCD add-on block for P250



HBT160F

	In (A)	P250
Fixed RCD	100 A	HBT100F
	160 A	HBT160F
	250 A	-



HBT250H

Adjustable RCD	100 A	HBT100H
	160 A	HBT160H
	250 A	HBT250H



HBT250L

Alarm only	100 A	HBT100L
	160 A	HBT160L
	250 A	HBT250L

RCD add-on block for P630



HBW630H

	In (A)	P630
Adjustable RCD	400 A	HBW400H
	630 A	HBW630H



HBW630L

Alarm only	400 A	HBW400L
	630 A	HBW630L

h3+ P160 - Switch disconnectors with front connections



HCS161AR

In (A)	3 poles	4 poles
125	HCS125AR	HCS126AR
160	HCS160AR	HCS161AR

h3+ P160 - Switch disconnectors with cable terminals



HCS161AC

In (A)	3 poles	4 poles
125	HCS125AC	HCS126AC
160	HCS160AC	HCS161AC

h3+ P250 - Switch disconnectors with front connections



HCT251AR

In (A)	3 poles	4 poles
200	HCT200AR	HCT201AR
250	HCT250AR	HCT251AR

h3+ P630 - Switch disconnectors with front connections



HCW631AR

In (A)	3 poles	4 poles
400	HCW400AR	HCW401AR
630	HCW630AR	HCW631AR

DIN rail mounting



HYT033H

		Poles	P160	P250	P630
DIN rail adaptor		3P / 4P	HYS033H	HYT033H	-

Cable terminals



HYT002H



HYT006H



HYT066H

		Poles	P160 Front connection	P160 Cable terminal	P250	P630
Integrated	1 wire Cu/Al	3P	-	HYS001H	HYT001H	HYW001H
		4P	-	HYS002H	HYT002H	HYW002H
External	1 wire Cu/Al	3P	HYS105H	HYS005H	HYT005H	-
		4P	HYS106H	HYS006H	HYT006H	-
	2 wires Cu/Al	3P	-	-	HYT007H	HYW007H
		4P	-	-	HYT008H	HYW008H
	6 wires Cu/Al	3P	HYS155H	HYS055H	HYT065H	-
		4P	HYS156H	HYS056H	HYT066H	-

Terminal extensions



HYB010H



HYB012H







HYB032H

		Poles	P160 Front connection	P160 Cable terminal	P250	P630
Straight terminal extension		3P/4P	HYS010H	HYS013H	HYB010H	HYW010H (250-400A) HYW013H (630A)
		3P	HYS011H	HYS014H	HYB011H	HYW011H (250-400A) HYW014H (630A)
Spreader terminal extension		4P	HYS012H	HYS015H	HYB012H	HYW012H (250-400A) HYW015H (630A)
		3P	HYS031H (16-50 A) HYS131H (63-160 A)	-	HYB031H	HYD031H (250-400A) HYD033H (630A)
Rear connection		4P	HYS032H (16-50 A) HYS132H (63-160 A)	-	HYB032H	HYD032H (250-400A) HYD034H (630A)

List of references

Terminal covers and protections

			Poles	P160	P250	P630
 HYT022H	Terminal cover for straight extensions		3P	HYS021H	HYT021H	HYW021H
			4P	HYS022H	HYT022H	HYW022H
 HYT024H	Terminal cover for spread extensions		3P	HYS023H	HYT023H	HYW023H
			4P	HYS024H	HYT024H	HYW024H
 HYT026H	Terminal cover for rear & plug-in connections		3P	HYS025H	HYT025H	HYW025H
			4P	HYS026H	HYT026H	HYW026H
  HYT051H	Isolating earth plate for Straight terminal cover		3P	HYS050H	HYT050H	HYW050H
			4P	HYS051H	HYT051H	HYW051H
  HYT053H	Isolating Earth plate for Spread terminal cover		3P	HYS052H	HYT052H	HYW052H
			4P	HYS053H	HYT053H	HYW053H
 HYT019H	Interphase barrier	50 mm	3/4P	HYS019H	-	-
		100 mm	3/4P	HYT019H		HYW019H

Electronic devices and accessories

P160 / P250 / P630

LSnI LSI LSiG Energy



HXS121H

AX/AL Energy	For communication only	-	-	-	HXS120H
	COM + 250 V AC contact wires	-	-	-	HXS121H
	COM + 125 V AC low level contact wires	-	-	-	HXS122H



HTC320H

COM Module	Without I/O	-	-	-	HTC310H
	With I/O	-	-	-	HTC320H
	Side support for wire	-	-	-	HTC100H



HTD210H

Panel display		-	-	-	HTD210H
---------------	--	---	---	---	----------------



HTP610H

Configuration tool					HTP610H
--------------------	--	--	--	--	----------------

Spare parts

	h3+ Configurator				HTP010H
--	------------------	--	--	--	----------------

	MIP adaptor for h3+				HTP020H
--	---------------------	--	--	--	----------------

	VGA cable 1m for HTP610H				HTP030H
--	--------------------------	--	--	--	----------------



HTP030H

	Power supply for HTP610H				HTP040H
--	--------------------------	--	--	--	----------------



HTP050H

	24 V DC Power supply	-	-	-	HTG911H
--	----------------------	---	---	---	----------------



HTG911H

List of references

Electronic devices and accessories

		P160 / P250 / P630					
		LSnI	LSI	LSIG	Energy		
 HTC330H	CIP - Adaptor	0.5 m	-	-	-	HTC330H	
		1.5 m	-	-	-	HTC340H	
		3 m	-	-	-	HTC350H	
		5 m	-	-	-	HTC360H	
		10 m	-	-	-	HTC370H	
 HTC140H	CIP - 24 V Adaptor	1.2 m	-	-	-	HTC140H	
 HTC130H	OAC/PTA adaptor	1.2 m	-	-	-	HTC130H	
 HTC150H	ZSI adaptor	1.2 m	-	-	-	HTC150H	
 HTC160H	NSP cable adaptor	1.2 m	-	-	-	HTC160H	
 HTG481H	Modbus cable	RJ45 - RJ45	0.2 m	-	-	-	HTG480H
			1 m	-	-	-	HTG481H
			2 m	-	-	-	HTG482H
			5 m	-	-	-	HTG484H
 HTG471H	RJ45 - RJ45 with earth		1 m	-	-	-	HTG471H
			2 m	-	-	-	HTG472H
			5 m	-	-	-	HTG474H
 HTG465H	RJ45 with earth	3 m	-	-	-	HTG465H	
 HTG485H		25 m	-	-	-	HTG485H	

Auxiliaries

P160 / P250 / P630



HXA021H

AX position auxiliary contact

HXA021H

Low level

HXA025H



HXA024H

AL tripping auxiliary contact

Left side

HXA024H

Low level

HXA026H

Right side

HXA027H

Low level

HXA028H



HXA005H

Shunt trip release

24 V DC

HXA001H

48 V DC

HXA002H

100 - 120 V~

HXA003H

200 - 240 V~

HXA004H

380 - 450 V~

HXA005H



HXA015H

Undervoltage release

24 V DC

HXA011H

100 - 120 V~

HXA013H

200 - 240 V~

HXA014H

380 - 450 V~

HXA015H



HXA051H

Delayed UVR

24 V DC

HXA051H

110 V~

HXA053H

240 V~

HXA054H

440 V~

HXA055H









HYA035H

Cable kit

0.75 mm² - 6 wires

HYA035H



Handles

		P160	P250	P630
 <p>HXT030H</p>	Direct rotary handle	HXS030H	HXT030H	HXW030H
	with interlocking	HXS032H	HXT032H	HXW032H
 <p>HXS888H</p>	Key kit for rotary handle	HXS888H	HXW888H	
	key lock only	HXS999H		
 <p>HXT031H</p>	On door rotary handle	kit with black IP55 handle and 200 mm shaft		HXS031H HXT031H HXW031H
	 <p>HXS901H</p>	black & grey	IP55	HXS901H HXW901H
 <p>HXS913H</p>	Shaft extension	200 mm	HXS912H	HXW912H
		320 mm	HXS913H	HXW913H
		500 mm	HXS915H	HXW915H
 <p>HXS920H</p>	Shaft guide for door rotary handle	HXS920H	-	
 <p>HXW033H</p>	Extended toggle	-	HXW033H	

Locking kits

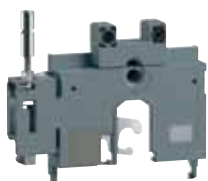

		P160	P250	P630
 <p>HXA039H</p>	Padlocking kit	HXA039H		
	Locking kit for on door rotary handle	HZC019		

Mechanical interlocking







		P160	P250	P630	
 <p>HXT166H</p>	Link interlock kit	3P	HXS165H	HXT165H	HXW165H
		4P	HXS166H	HXT166H	HXW166H
 <p>HXT066H</p>	Mechanical interlock (1 front cover)	3P / 4P	HXS066H	HXT066H	HXW066H
 <p>HXB070H</p>	Cable for mechanical interlock	1 m	HXB070H		
		1.5 m	HXB071H		

List of references

Motor operators

		P250	P630	
 HXT040H	Motor operator with auto-reset	24 V DC	HXT040H	-
		24 - 48 V DC	-	HXW040H
		48 V DC	HXT048H	-
		100 - 110 V AC/DC	HXT041H	-
		100 - 110 V DC	-	HXW041H
		110 - 240 V AC	-	HXW042H
		200 - 220 V AC/DC	HXT045H	-
		230 - 240 V AC	HXT042H	-
 HXT040HK	Motor operator with auto-reset and Ronis key lock	24 V DC	HXT040HK	-
		24 - 48 V DC	-	HXW040HK
		48 V DC	HXT048HK	-
		100 - 110 V AC/DC	HXT041HK	-
		100 - 110 V DC	-	HXW041HK
		110 - 240 V AC	-	HXW042HK
		200 - 220 V AC/DC	HXT045HK	-
		230 - 240 V AC	HXT042HK	-
 HXT043H	Motor operator without auto-reset	24 V DC	HXT043H	-
		24 - 48 V DC	-	HXW043H
		48 V DC	HXT049H	-
		100 - 110 V AC/DC	HXT046H	-
		100 - 110 V DC	-	HXW046H
		110 - 240 V AC	-	HXW044H
		200 - 220 V AC/DC	HXT047H	-
		230 - 240 V AC	HXT044H	-
 HXT043HK	Motor operator without auto-reset and Ronis key lock	24 V DC	HXT043HK	-
		24 - 48 V DC	-	HXW043HK
		48 V DC	HXT049HK	-
		100 - 110 V AC/DC	HXT046HK	-
		100 - 110 V DC	-	HXW046HK
		110 - 240 V AC	-	HXW044HK
		200 - 220 V AC/DC	HXT047HK	-
		230 - 240 V AC	HXT044HK	-
 HXB068H	Electrical interlock for Motor operator	For 2 same motors	HXB068H	HXD068H
		For P250 to P630 motors	HXB069H	

Plug-in system

		P160	P250	P630	
 <p>HYT201H</p>	Plug-in base	3P	HYS200H	HYT200H	HYW200H
		4P	HYS201H	HYT201H	HYW201H
 <p>HYT301H</p>	Plug-in circuit breaker conversion kit	3P	HYS300H HYS310H (≤50 A)	HYT300H	HYW300H
		4P	HYS301H HYS311H (≤50 A)	HYT301H	HYW301H
 <p>HYC250H HYC352H</p>	Auxiliary circuit terminal	Base side	HYC250H		
		MCCB side 2 wires	HYC352H		
		MCCB side 3 wires	HYC353H		
 <p>HYT328H</p>	L connection	1P	HYS328H	HYT328H	HYW328H
 <p>HYC321H</p>	Terminal cover for plug-in base	3P	HYS321H	HYC321H	HYD321H
		4P	HYS322H	HYC322H	HYD322H
 <p>HYS256H</p>	Safety trip		HYS256H	HYW256H	
		Kit for Quadro SX and Unimes H enclosures	HYS257H	HYT257H	HYW257H

List of references

Withdrawable system

		P250	P630
	Base for withdrawable circuit breaker		
	3P	HYT330H	HYW330H
	4P	HYT331H	HYW331H
<hr/>			
	Withdrawable circuit breaker adaptor		
	3P	HYT332H	HYW332H
	4P	HYT333H	HYW333H
<hr/>			
	Locking key kit		
		HXT890H	HXW890H
<hr/>			
	Auxiliary circuit terminal		
	Base side	HYC250H	
	MCCB side 2 wires	HYC352H	
	MCCB side 3 wires	HYC353H	
<hr/>			
	L connection		
	1P	HYT328H	HYW328H
<hr/>			
	Position switch	HYC255H	
	Spare safety trip (safety trip included as standard)	HYS256H	HYW256H
	Kit for Quadro SX and Unimes H enclosures	HYT257H	HYW257H

HYS256H

h3+ electromechanical range

Page

01 TM and MAG (ICB) trip units

42

TM

h3+ circuit breakers fitted with thermal-magnetic trip units are for use in electrical distribution applications. They are used for protection of conductors and loads supplied by transformers or generators and also if the fault current is limited due to the impedance of the conductor lengths. Settings are made with adjustment dials at the front of the products.



Trip unit TM

Thermal protection Ir (A)

Thermal protection against overloads is based on the principle of a bimetal actuator working in an inverse time curve I^2t based on temperature rise limits. Over this limit the bimetal actuator trips the circuit breaker.

The thermal protection threshold I_r can be adjusted between $0.63 \times I_n$ and I_n .

Time delay is fixed.

Magnetic protection Ii (A)

Magnetic protection against short-circuits is adjustable and allows instantaneous tripping.

P160: adjustable from 6 to 12 times the nominal rating (I_n) of circuit breakers up to 125 A and 6 to 10 times for the 160 A.

P250: adjustable from 6 to 13 times the nominal rating (I_n) of circuit breakers up to 160 A, 6 to 12 times for 200 A and 6 to 10 times for 250 A.

Protection against earth leakage current

Protection against earth leakage current is ensured by an RCD add-on block fitted to the circuit breaker or an RCD relay operating the shunt trip release or under voltage coil of the circuit breaker (option as an accessory).

P160 can only be associated with an RCD relay.

P250 works with both solutions.

Neutral protection on TM circuit breakers

P160 and P250 TM circuit breakers are available as:

- 3P3D:
3-pole device with detection on each pole, neutral protection is not possible.
- 4P4D:
4-pole device with adjustable neutral protection on the left pole.

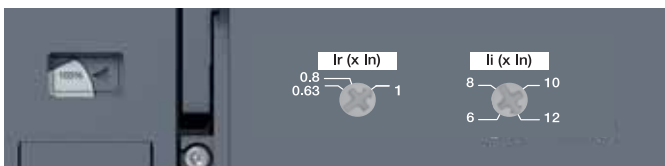

Trip unit TM with neutral adjustment

TM trip units

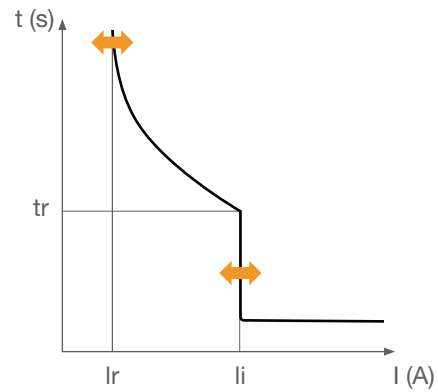

In at 50 °C	25 A	40 A	50 A	63 A	80 A	100 A	125 A	160 A	200 A	250 A
P160	x	x		x	x	x	x	x		
P250			x	x	x	x	x	x	x	x

Thermal protection

Ir ... x In (tripping current between 1.05 and 1.30 x Ir)	adjustable 0.63 - 0.8 - 1
Time delay tr	fixed

Magnetic protection

li (+/- 20 %) x In	adjustable
P160	6 - 8 - 10 - 12 6 - 7 - 8 - 9 - 10
P250	6 - 8 - 10 - 13 6 - 8 - 10 - 12 6 - 7 - 8 - 9 - 10
Time delay	fixed

Neutral protection

3P	-
4P	0 % or 100 % of Ir

h3+ electro-mechanical range

MAG (ICB)

The h3+ circuit breakers fitted with magnetic trip units are destined for a use in electrical distribution applications where only magnetic protection is required. They are mainly used for motor protection in association with a thermal relay and a power contactor.

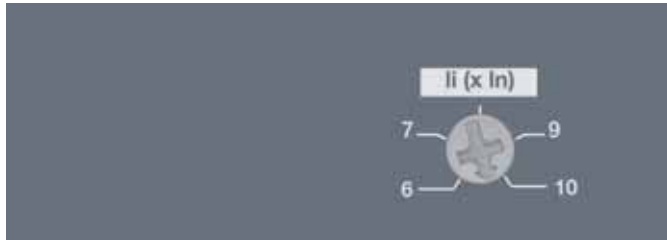

Trip unit MAG

Magnetic protection li (A)

Magnetic protection against short-circuits is adjustable and allows instantaneous tripping.

P160: adjustable from 6 to 12 times the rating (I_n) of circuit breakers up to 125 A and 6 to 10 times for the 160 A.

P250: adjustable from 6 to 13 times the rating (I_n) of circuit breakers up to 160 A, 6 to 12 times for 200 A and 6 to 10 times for 250 A.

Circuit breakers with MAG trip unit

P160 and P250 MAG circuit breakers are available as 3P (3P3D) and 4P (4P4D).

MAG trip units

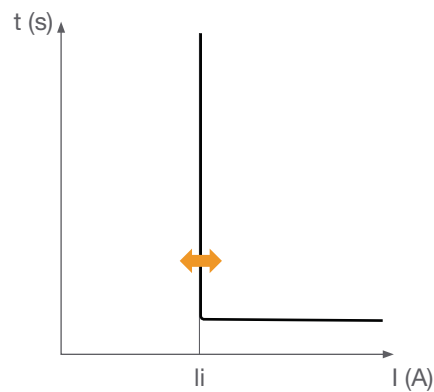

I_n at 50 °C	25 A	40 A	50 A	63 A	80 A	100 A	125 A	160 A	200 A	250 A
P160	x	x	x	x	x	x	x	x		
P250						x	x	x	x	x

Magnetic protection

li (+/- 20 %) $x I_n$	adjustable									
P160	6 - 8 - 10 - 12							6 - 7 - 8 - 9 - 10		
P250	6 - 8 - 10 - 13								6 - 8 - 10 - 12	6 - 7 - 8 - 9 - 10
Time delay	fixed									

Neutral protection

3P	-
4P	same as phases

h3+ electronic range

Page

01 Electronic trip units	46
02 Communication devices	58

LSnI

h3+ circuit breakers fitted with LSnI trip units are for use in electrical distribution applications. They are used for protection of conductors and also if the fault current is limited due to the impedance of the conductor lengths. Settings via adjustment dials are at front of the products and allow an accurate protection settings and a tripping curve independent of the ambient temperature.

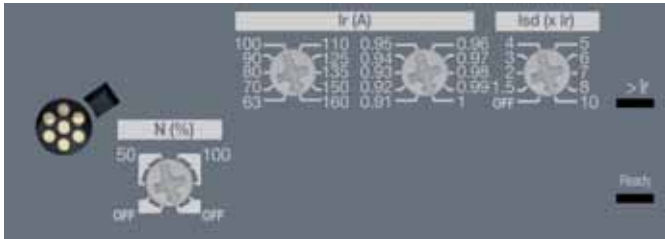

Trip unit LSnI

Long time protection L

Long time protection provides an inverse time curve I^2t against overloads.

Fine tuning of I_r (A) is done with 2 dials.

Time delay t_r (s) is non-adjustable.

Short time protection S

Short time protection is for short-circuits. I_{sd} (A) is adjustable with a dial from 1.5 to 10 times the long time protection I_r of the circuit breaker. Short time protection can be disabled.

Time delay t_{sd} is non-adjustable.

Non-adjustable instantaneous protection li

Instantaneous short-circuit protection I_i (A) is fixed.

Non tripping time delay is 10 ms and the maximum breaking time delay is 50 ms.

Protection against earth leakage current

Protection against earth leakage current is ensured by an RCD add-on block fitted to the circuit breaker or an RCD relay operating the shunt trip release or under voltage coil of the circuit breaker (option as an accessory).

P160 can only be associated with a separate RCD relay.

P250 works with both solutions.

Neutral protection on LSnI circuit breakers

P160 and P250 LSnI circuit breakers are available as:

- 3P3D: No neutral protection.
- 4P4D: Neutral protection is set with a dial on one of the following positions: OFF; 50 % of I_r and I_{sd} ; 100 % of I_r and I_{sd} . Time delay remains the same as t_r and t_{sd} .



Neutral protection dial



Front LED Indicators

Front LED Indicators

Ready LED: Green when the trip unit is ready to protect. It blinks in orange in case of a failure in the trip unit auto test. If the latter occurs, the MCCB is considered defective and no longer guarantees the protection of the electrical installation.

> I_r LED: It starts blinking red when $I \geq 105\% I_r$ and remains red in case $I > 112\% I_r$.



MIP Connector

MIP Connector

Connection for Configuration tool HTP610H.

LSnl trip units

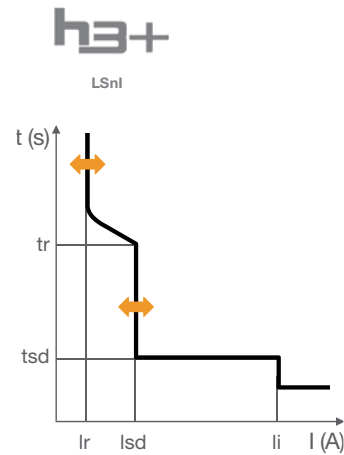
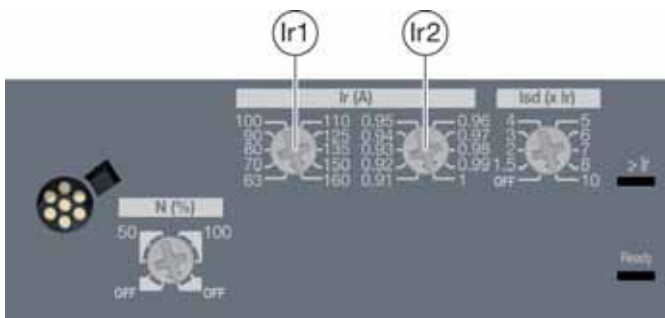

In	40 A	100 A	160 A	250 A
P160	X	X	X	
P250	X	X	X	X

Long time protection

Ir (pick-up tripping between 1.05 and 1.20 x Ir)

Ir (A)	In = 40 A	16 - 18 - 20 - 22 - 25 - 28 - 32 - 34 - 37 - 40
	In = 100 A	40 - 45 - 50 - 57 - 63 - 72 - 80 - 87 - 93 - 100
	In = 160 A	63 - 70 - 80 - 90 - 100 - 110 - 125 - 135 - 150 - 160
	In = 250 A	90 - 100 - 110 - 125 - 140 - 160 - 180 - 200 - 225 - 250
Ir (A) = Ir1 x Ir2	Fine tuning Ir2	0.91 - 0.92 - 0.93 - 0.94 - 0.95 - 0.96 - 0.97 - 0.98 - 0.99 - 1

Time delay (s) accuracy -21% / +1%	tr at 6 x Ir	5
---------------------------------------	--------------	---

S Short time protection

Isd = OFF ; = Ir x ...	Accuracy +/- 10 %	1.5 - 2 - 3 - 4 - 5 - 6 - 7 - 8 - 10
Time delay (ms)	tsd	100
	Non-tripping time	80
	Maximum breaking time	150

I Instantaneous protection

Instantaneous pickup li = In x ... accuracy +/- 15 %	In = 40 A ; 100 A	15
	In = 160 A ; 250 A	11
Time delay (ms)		-
	Non-tripping time	10
	Maximum breaking time	50

Neutral protection (only for 4P)

Neutral protection = Phase protection (Ir, Isd) x ...		OFF - 50 % - 100 %
	Instantaneous protection	same as phases
	Time delay	same as phases for tr, tsd and instantaneous

h3+ electronic range

LSI

h3+ circuit breakers fitted with LSI trip units are for use in electrical distribution applications for protection of conductors and loads in case of a wide range of protection settings is required. Settings with adjustment dials are at front of products and allow an accurate protection setting and a tripping curve that is independent of the ambient temperature.

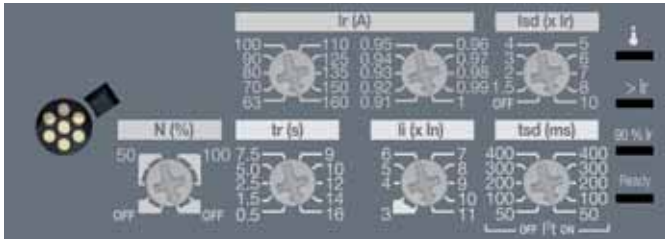

Trip unit LSI

Long time protection L

Long-time protection provides an inverse time curve I^2t against overloads.

Fine tuning of I_r (A) is done with two dials.

Time delay t_r (s) is adjustable via one dial.

Short time protection S

Short time protection is for short-circuits. I_{sd} (A) is adjustable with a dial from 1.5 to 10 times the long time protection I_r of the circuit breaker. Short time protection can be disabled.

Time delay t_{sd} is adjustable using a dial from 50 to 400 ms with the possibility of including an inverse time curve (I^2t OFF or ON).

Instantaneous protection Ii

Instantaneous short-circuit protection I_i (A) is adjustable from:

- 3 to 15 times the nominal current I_n for circuit breakers with I_n up to 100 A,
- 3 to 11 times the nominal current I_n for P160 and P250 circuit breakers with I_n 160 A or 250 A and for P630 with I_n 630 A.
- 3 to 12 times the nominal current I_n for P630 circuit breakers with I_n 250 A or 400 A;

Non-tripping time delay is 10 ms and the maximum breaking time delay is 50 ms.

Protection against earth leakage current

Protection against earth leakage current is ensured by an RCD add-on block fitted to the circuit breaker or an RCD relay operating the shunt trip release or under voltage coil of the circuit breaker (option as an accessory).

P160 can only be associated with an RCD relay.

P250 and P630 work with both solutions.

Neutral protection on LSI circuit breakers

P160, P250 and P630 LSI circuit breakers are available as:

- 3P3D: No neutral protection.
- 4P4D: Neutral protection is set with a dial on one of the following positions: OFF; 50 % of I_r and I_{sd} ; 100 % of I_r and I_{sd} . Time delay remains the same as t_r and t_{sd} .



Neutral protection dial LSI trip unit

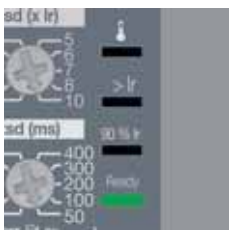

Front LED indicators

Front LED indicators

Temperature LED: It turns red when the internal temperature of the trip unit reaches 105 °C.

> I_r LED: It starts blinking red when $I \geq 105 \% I_r$ and remains red in case $I > 112 \% I_r$.

90 % I_r LED: It starts blinking orange when $I \geq 90 \% I_r$ and remains orange when the corresponding PTA output contact is activated.

Ready LED: Green when the trip unit is ready to protect. It blinks in orange in case of a failure in the trip unit auto test. If the latter occurs, the MCCB is considered defective and no longer guarantees the protection of the electrical installation.



MIP Connector

MIP Connector

Connection for Configuration tool HTP610H.

LSI trip units

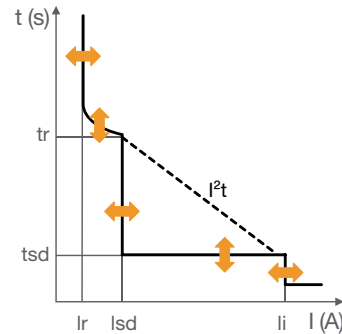
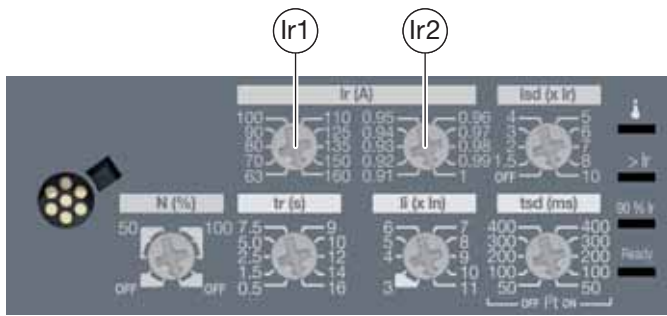

In	40 A	100 A	160 A	250 A	400 A	630 A
P160	X	X	X			
P250	X	X	X	X		
P630				X	X	X

Long time protection

Ir (pick-up tripping between 1.05 and 1.20 x Ir)

Ir1 (A)	In = 40 A	16 - 18 - 20 - 22 - 25 - 28 - 32 - 34 - 37 - 40
	In = 100 A	40 - 45 - 50 - 57 - 63 - 72 - 80 - 87 - 93 - 100
	In = 160 A	63 - 70 - 80 - 90 - 100 - 110 - 125 - 135 - 150 - 160
	In = 250 A	90 - 100 - 110 - 125 - 140 - 160 - 180 - 200 - 225 - 250
	In = 400 A	160 - 180 - 200 - 225 - 250 - 300 - 350 - 370 - 400
	In = 630 A	250 - 300 - 350 - 370 - 400 - 500 - 600 - 630
Ir (A) = Ir1 x Ir2	Fine tuning Ir2	0.91 - 0.92 - 0.93 - 0.94 - 0.95 - 0.96 - 0.97 - 0.98 - 0.99 - 1
Time delay (s) accuracy -21% / +1%	tr at 6 x Ir	0.5 - 1.5 - 2.5 - 5 - 7.5 - 9 - 10 - 12 - 14 - 16

S Short time protection

Isd = OFF ; = Ir x ...	Accuracy +/- 10 %	1.5 - 2 - 3 - 4 - 5 - 6 - 7 - 8 - 10				
Time delay (ms)	tsd I²t OFF	50	100	200	300	400
	tsd I²t ON	50	100	200	300	400
	Non-tripping time	20	80	180	280	380
	Maximum breaking time	80	150	250	350	450

I Instantaneous protection

Instantaneous pickup li = In x ... accuracy +/- 15 %	P160 - P250	In = 40 A ; 100 A	3 - 4 - 5 - 6 - 7 - 8 - 10 - 12 - 15
		In = 160 A ; 250 A	3 - 4 - 5 - 6 - 7 - 8 - 9 - 10 - 11
	P630	In = 250 A ; 400 A	3 - 4 - 5 - 6 - 7 - 8 - 10 - 11 - 12
		In = 630 A	3 - 4 - 5 - 6 - 7 - 8 - 9 - 10 - 11
Time delay (ms)	Non-tripping time	10	
	Maximum breaking time	50	

Neutral protection (only for 4P)

Neutral protection = Phase protection (Ir, Isd) x ...	OFF - 50 % - 100 %
Instantaneous protection	same as phases
Time delay	same as phases for tr, tsd and instantaneous time delays for phases

LSIG

h3+ circuit breakers fitted with LSIG trip units are for use in electrical distribution applications for protection of conductors and loads in cases where a ground fault protection is required in a TN-S earthing system. Settings are done with adjustment dials located at the front of the products. These dials allow accurate protection setting and a tripping curve independent of the ambient temperature.

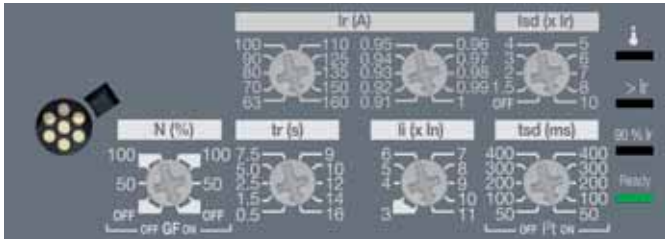

Trip unit LSIG



Neutral protection dial LSIG trip unit

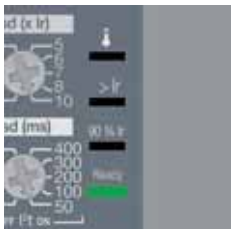

Front LED indicators



MIP Connector

Long time protection L

Long time protection provides an inverse time curve I^2t against overloads.

Fine tuning of I_r (A) is done with two dials.

Time delay t_r (s) is adjustable via one dial.

Short time protection S

Short time protection is for short-circuits. I_{sd} (A) is adjustable with a dial from 1.5 to 10 times the long time protection I_r of the circuit breaker. Short time protection can be disabled.

Time delay t_{sd} is adjustable via a dial from 50 to 400 ms with the possibility of including an inverse time curve (I^2t OFF or ON).

Instantaneous protection Ii

Instantaneous short-circuit protection I_i (A) is adjustable from:

- 3 to 15 times the nominal current I_n for circuit breakers with I_n up to 100 A,
 - 3 to 11 times the nominal current I_n for P250 circuit breakers with I_n 160 A or 250 A.
 - 3 to 12 times the nominal current I_n for P630 circuit breakers with I_n 250 A or 400 A;
- Non-tripping time delay is 10 ms and the maximum breaking time delay is 50 ms.

Ground fault protection G

Ground fault protection is an insulation fault type including a portion of an inverse time curve I^2t . It can be activated or deactivated (GF OFF or ON). It is with a fixed pick-up I_g of 40% x I_n for $I_n = 40$ A, 20% x I_n for $I_n > 40$ A and fixed time delay t_g of 200 ms.

Protection against earth leakage current

Protection against earth leakage current is ensured by an RCD add-on block fitted to the circuit breaker or an RCD relay operating the shunt trip release or under voltage coil of the circuit breaker (option as an accessory). P160 can only be associated with an RCD relay. P250 and P630 works with both solutions.

Neutral protection on LSI circuit breakers

P160, P250 and P630 LSIG circuit breakers are available as:

- 3P3D: No neutral protection.
- 4P4D: Neutral protection is set with a dial on one of the following positions: OFF; 50 % of I_r and I_{sd} ; 100 % of I_r and I_{sd} . Time delay remains the same as t_r and t_{sd} .

Front LED indicators

Temperature LED: It turns red when the internal temperature of the trip unit has reached 105 °C.

> I_r LED: It starts blinking red when ≥ 105 % I_r and remains red in case $I > 112$ % I_r .

90% I_r LED: It starts blinking orange when $I \geq 90$ % I_r and remains orange when the corresponding PTA output contact is activated.

Ready LED: Green when the trip unit is ready to protect. It blinks in orange in case of a failure in the trip unit auto test. If the latter occurs, the MCCB is considered defective and no longer guarantees the protection of the electrical installation.

MIP Connector

Connection for Configuration tool HTP610H.

LSIG trip units

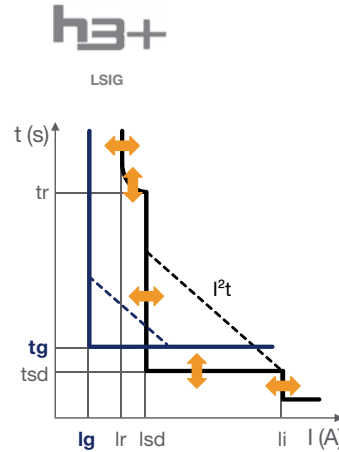
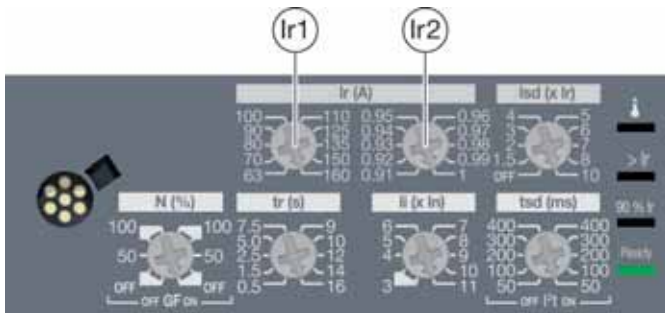

In		40 A	100 A	160 A	250 A	400 A	630 A
	P250	X	X	X	X		
	P630				X	X	X

Long time protection

Ir (pick-up tripping between 1.05 and 1.20 x Ir)

Ir1 (A)	In = 40 A	16 - 18 - 20 - 22 - 25 - 28 - 32 - 34 - 37 - 40
	In = 100 A	40 - 45 - 50 - 57 - 63 - 72 - 80 - 87 - 93 - 100
	In = 160 A	63 - 70 - 80 - 90 - 100 - 110 - 125 - 135 - 150 - 160
	In = 250 A	90 - 100 - 110 - 125 - 140 - 160 - 180 - 200 - 225 - 250
	In = 400 A	160 - 180 - 200 - 225 - 250 - 300 - 350 - 370 - 400
	In = 630 A	250 - 300 - 350 - 370 - 400 - 500 - 600 - 630
Ir (A) = Ir1 x Ir2	Fine tuning Ir2	0.91 - 0.92 - 0.93 - 0.94 - 0.95 - 0.96 - 0.97 - 0.98 - 0.99 - 1
Time delay (s) accuracy -21% / +1%	tr at 6 x Ir	0.5 - 1.5 - 2.5 - 5 - 7.5 - 9 - 10 - 12 - 14 - 16

S Short time protection

Ird = OFF ; = Ir x ...	Accuracy +/- 10 %	1.5 - 2 - 3 - 4 - 5 - 6 - 7 - 8 - 10				
Time delay (ms)	tsd I ² t OFF	50	100	200	300	400
	tsd I ² t ON	50	100	200	300	400
	Non-tripping time	20	80	180	280	380
	Maximum breaking time	80	150	250	350	450

I Instantaneous protection

Instantaneous pickup P160 - P250 li = In x ... accuracy +/- 15 %	P630	In = 40 A ; 100 A	3 - 4 - 5 - 6 - 7 - 8 - 10 - 12 - 15
		In = 160 A ; 250 A	3 - 4 - 5 - 6 - 7 - 8 - 9 - 10 - 11
		In = 250 A ; 400 A	3 - 4 - 5 - 6 - 7 - 8 - 10 - 11 - 12
		In = 630 A	3 - 4 - 5 - 6 - 7 - 8 - 9 - 10 - 11
Time delay (ms)	Non-tripping time	10	
	Maximum breaking time	50	

G Ground fault protection

GF = OFF; GF = ON with Ig (A) = ...%In	In = 40 A	40	
	In > 40 A	20	
	Time Delay (ms)	tsd I ² t OFF	200
		tsd I ² t ON	200
		Non-tripping time	180
		Maximum breaking time	250

Neutral protection (only for 4P)

Neutral protection = Phase protection (Ir, Ird) x ...	OFF - 50 % - 100 %
Instantaneous protection	same as phases
Time delay	same as phases for tr, tsd and instantaneous time delays for phases

h3+ electronic range

Energy trip units

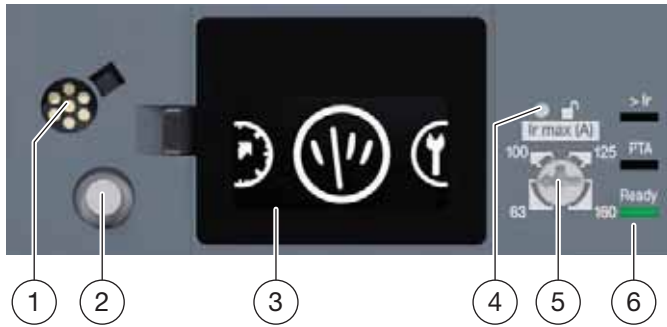

- 1 Maintenance interface Port (MIP)
- 2 h3+ joystick
- 3 Embedded display
- 4 Unlock button
- 5 Ir max dial
- 6 Front LED indicators

h3+ MCCBs fitted with Energy trip units are for protection of conductors and loads in electrical distribution applications. They present a wide range of settings to cope with the requirements of load protection and circuit selectivity in electrical distributions.

Furthermore, they offer the user the possibility to do energy management by showing all measurements collected by the embedded sensors working on the basis of Rogowski technology.

Moreover, advanced remote functions and alarm management features are provided.

Energy functions:

- Measurements visualisation
- Protection settings configuration
- Alarm management
- Integrated OAC contact and PTA output contact
- Event logs
- Communication interface to the Panel display and to the Modbus COM module

Embedded display h3+ Energy



Embedded display horizontal

h3+ Energy MCCBs display the protection settings and the main measurements on the high contrast embedded screen. The h3+ joystick located at the front of the MCCB allows the navigation through the four main menus: Protection, Measure, Configuration and Information.

Even if the Energy trip unit is self-powered by a minimum of current flowing through the MCCB, an external 24 V DC power supply is recommended to make the display available under all operating conditions and to allow the Energy trip unit to fulfill all the functions of measurement and memorisation of events (Trips, alarms).

An easy configuration of the screen rotation by 90°, 180° or 270° is possible to guarantee a good reading of the display regardless of the mounting position of the Energy MCCB. Moreover, the user can set his favourite measurements that will keep scrolling on the screen when the embedded display is in Live mode.

Measurements



Embedded display Measurements menu

The h3+ Energy MCCBs measure real time rms value of the current, voltage, frequency, power and others. Every instantaneous measurement can be associated with a maximeter. Maximeters can be reset.

The h3+ Energy MCCBs also measure all energies with a Class 1 accuracy according to IEC 61557-12.

The partial energy can be reset.

Power demand values can also be calculated by h3+ Energy MCCB. These calculations can be made using a fixed or sliding interval that can be set from 5 to 60 minutes in steps of 1 minute. The calculation window can be synchronised with a signal sent via the communication system through the Com module. These demand values can be used to provide trend curves and forecasts based on this data. They will provide basic data to draw a load profile and to adjust consumption to the subscribed power.

In addition to that, h3+ Energy MCCBs measure the total harmonic distortion (THD) of current and voltage.

Measurements

			Embedded display	HTD210H Panel display
Real time rms measurements				
Current	Phase and neutral	I1, I2, I3; IN	x	x
	Average	$I_{avg} = (I1+I2+I3)/3$		x
	Highest current of 3 phases	I _{max} of I1, I2, I3, IN		x
	Ground fault	IG	x	x
	Unbalanced between phases	% I _{avg}		x
Voltage	Phase to phase	U12, U23, U31	x	x
	Phase to neutral	V1N, V2N, V3N	x	x
	Average phase to phase	$U_{avg} = (U12 + U21 + U23) / 3$		x
	Average phase to neutral	$V_{avg} = (V1N + V2N + V3N) / 3$		x
	Unbalanced	% U _{avg} and % V _{avg}		x
	Phase sequence	1 - 2 - 3, 1 - 3 - 2	x	x
Frequency	Frequency	f	x	x
Power	Active	P, total / per phase	x	x
	Reactive	Q, total / per phase	x	x
	Apparent	S, total / per phase		x
	Power factor and cos φ (fundamental)	PF and cos φ, total and per phase	x (cos φ tot)	x
Maximeter				
	Last maximum of real time rms voltage, current and power measurements	Reset via Embedded display (voltage, current, power) or HTD210H	x	x
Energy metering				
Energy	Active (kWh), reactive (kvarh), apparent (kVAh)	Total, partial, direct, reverse	x (except apparent energy)	x
Demand values				
Demand power	Active (kW), reactive (kvar), apparent (kVA)	Present value on the selected window Maximum demand since last reset		x
On demand value	Sliding, fixed or com-synchronised	Adjustable from 5 to 60 minutes in steps of 1 minute		x
Power quality				
Total harmonic distortion	Of voltage	THDU, THDV of the Ph-Ph and Ph-N voltage		x
	Of current	THDI of the phase current		x

h3+ electronic range

Measurement accuracy

Accuracies are those of the entire measurement system, including the sensors:

- Current: Class 0.5 according to IEC 61557-12
- Voltage: Class 0.5 according to IEC 61557-12
- Power and energy: Class 1 according to IEC 61557-12
- Frequency: Class 0.2 according to IEC 61557-12

Unlock button



Access to setting modifications or reset of measurements via the embedded display is protected by a locking function. The embedded display can be unlocked by the unlock button which can only be handled by a tool. It is recommended to use a less sharp tool like a pencil than a screwdriver or a knife.

Protection settings

h3+ Energy MCCB provides a long time protection L with an adjustable current pick-up I_r and adjustable time delay t_r . They provide also a short time protection S with adjustable I_{sd} and t_{sd} and with the possibility of including an inverse time curve (I^2t OFF or ON) part. Instantaneous short-circuit protection I_i is also adjustable with a fixed time delay.



Embedded display Protection settings

In unlocked mode the embedded display changes its colour and shows an “unlocking” icon. The unlocked mode is also activated by handling the I_r max dial.

The embedded display can be relocked via the h3+ joystick or automatically after 30 seconds of non-use.

Ground fault protection can be activated or deactivated. It is with adjustable pick-up I_g and adjustable time delay t_g . It is an insulation fault type including a portion of an inverse time curve I^2t (I^2t ground OFF or ON).

Neutral protection is available on 4P Energy MCCB:

It is adjustable in following positions: OFF; 50 % of I_r and I_{sd} ; 100 % of I_r and I_{sd} . Time delay remains the same as t_r and t_{sd} .

Protection against earth leakage current is ensured by an RCD add-on block fitted to the circuit breaker or an RCD relay operating the shunt trip release or under voltage coil of the circuit breaker (option as an accessory).

P160 can only be associated with a RCD relay. P250 works with both solutions.

Current pick-up threshold I_r

The current pick-up I_r is set by the I_r max dial. Handling the I_r max dial automatically unlocks the embedded display. The effective I_r value is displayed on the display. It is then possible to fine tune the I_r and other protection settings via the display joystick. Without any joystick action or dial handle after 30 seconds, the embedded display will lock.

Front LED indicators

> I_r LED: It starts blinking red when $I \geq 105\% I_r$ and remains red in case $I > 112\% I_r$.

PTA LED: It starts blinking orange when PTA threshold is reached (default 90 %) and remains orange when the corresponding PTA output contact is activated.

Ready LED: Green when the trip unit is ready to protect. It blinks in orange in case of a failure in the Energy trip unit auto test. If the latter occurs, the MCCB is considered defective and no longer guarantees the protection of the electrical installation.

Autotest consists of testing all the sensors of the trip unit to make sure that the trip unit is ready to protect.

A failure in the autotest trips the MCCB and means that the MCCB should be replaced immediately.



Front LED indicators

Energy trip units



h3+
Energy

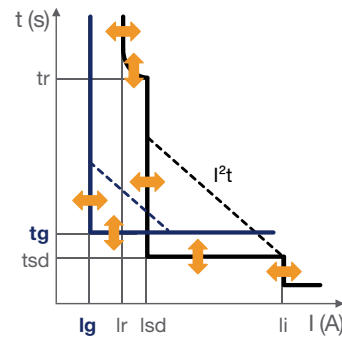

In	40 A	100 A	160 A	250 A	400 A	630 A
P160	X	X	X			
P250	X	X	X	X		
P630				X	X	X

Long time protection

Ir (pick-up tripping between 1.05 and 1.20 x Ir)

Ir (A) ; Ir max (A)	In = 40 A	In = 100 A	In = 160 A	In = 250 A	In = 400 A	In = 630 A
	16 - 25 - 32 - 40	40 - 63 - 80 - 100	63 - 100 - 125 - 160	90 - 100 - 125 - 160 - 200 - 250	160 - 200 - 250 - 300 - 350 - 400	250 - 300 - 350 - 400 - 500 - 630

Fine tuning of 1A steps below Ir max is available using the dial on the front of the tripping unit until reaching the minimal value.

Time delay (s) accuracy -21% / +1%	tr (s) at 6 x Ir	0.5 - 1.5 - 2.5 - 5 - 7.5 - 9 - 10 - 12 - 14 - 16
------------------------------------	------------------	---

S Short time protection

I _{sd} = OFF ; = Ir x ...	Accuracy +/- 10 %	1.5 to 10 with steps of 0.5
Time delay (ms)	tsd I ² t OFF	50 100 200 300 400
	tsd I ² t ON	50 100 200 300 400
	Non-tripping time	20 80 180 280 380
	Maximum breaking time	80 150 250 350 450

I Instantaneous protection

Instantaneous pickup I _i = In x ... accuracy +/- 15 %	P160 - P250	In = 40 A ; 100 A	In = 160 A ; 250 A	P630	In = 250 A ; 400 A	In = 630 A
		3 to 15 with steps of 0.5	3 to 11 with steps of 0.5		3 to 12 with steps of 0.5	3 to 11 with steps of 0.5
Time delay (ms)		Non-tripping time	10		Maximum breaking time	50

G Ground fault protection

Ground fault pickup I _g I _g = OFF; = % In	In = 40 A	In > 40 A
	40 to 100 with steps of 5	20 to 100 with steps of 5
Time Delay (ms)	tsd I ² t OFF	50 100 200 300 400 500
	tsd I ² t ON	50 100 200 300 400 500
	Non-tripping time	20 80 180 280 380 480
	Maximum breaking time	80 150 250 350 450 550

Neutral protection (only for 4P)

Neutral protection = Phase protection	(I _r , I _{sd}) x ...	OFF - 50 % - 100 %
	Instantaneous protection	same as phases
	Time delay	same as phases for tr, tsd and instantaneous time delays for phases

h3+ electronic range

Alarm management

The Energy MCCBs allow the management of four types of alarms:

- Overload prealarm
- Trip alarm
- Custom alarm
- System alarm

Overload prealarm

The overload prealarm PTA is a predefined alarm to be set in % of I_r and % of t_r with a default value of 90 % x I_r and 50 % of t_r .

It is assigned to the PTA output contact.

Trip alarm

There are five types of trip alarms. They correspond to the following events: Long time trip L, Short time trip S, Instantaneous trip I, Ground fault trip G, trip test (performed from Configuration tool).

Custom alarm

The user can activate up to twelve custom alarms to audit an event of measurement by defining thresholds and time delays.

The same measurement can be used for different custom alarms to precisely monitor certain values, e.g. the frequency or the voltage.

Priorities can be set for the Trip alarms and the twelve custom alarms.

System alarm

There are three types of System alarms: Trip unit internal error, Trip unit overtemperature and Neutral pole disconnection.

System alarms are non settable high priority alarms.

Alarms can be set and read via the Panel display HTD210H or the Configuration tool HTP610H.

Event management

The h3+ Energy MCCBs have a non-volatile memory that saves all data on alarm events, trip events and settings change events, counter values even if power supply is lost.

Time-stamped log table:

- 10 last trip events
- 40 last custom alarm events
- 5 last settings of each setting parameter

Each event is stored with:

- Time-stamping: date and time of event
- Status for custom alarms: pick up / drop out

The h3+ Energy event logs can be displayed on the Panel Display HTD210H (trip and alarm events), via the Configuration tool HTP610H (trip, alarm and setting events) or via Modbus communication.

Zone selective interlocking (ZSI)

The h3+ Energy MCCBs are fitted with ZSI connectors to interconnect h3+ Energy MCCBs to provide zone selective interlocking for short-time (I_{sd}) and ground-fault (I_g) protection, without a time delay. For Energy P160, the ZSI function is available only with one terminal (ZSI2) to connect to an upstream circuit breaker. For Energy P250, the ZSI function is available with one terminal (ZSI2) to connect to an upstream circuit breaker and with another terminal (ZSI1) to connect to a downstream circuit breaker.

Connectivity on h3+ electronic MCCB

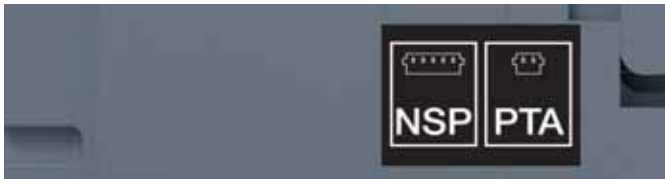

NSP / PTA connection ports on Energy 3P MCCBs



PTA output contact



MIP connector



H3+ Energy CIP, ACP, ZSI and OAC connectors

OAC output contact

The Energy MCCBs have an integrated OAC output contact on the right side inside of the product.

The user can assign one of the following types of alarms to the OAC output contact:

- Overload prealarm
- Custom alarm
- System alarm

It is a digital output contact with the following characteristics:

- ≤ 24 VDC, 100 mA.

PTA output contact

All h3+ LSI, LSIG and Energy MCCBs have an integrated PTA output contact on the left side of the product.

This contact is associated to the overload prealarm PTA function fitted on the LSI, LSIG and Energy MCCBs.

It is a digital output contact with the following characteristics:
- ≤ 24 VDC, 100 mA.

MIP connector

All h3+ LSnl, LSI, LSIG and Energy MCCBs have a maintenance connector on the front of the device to connect to the Configuration Tool HTP610H (see next page).

NSP port

In a 3-phase installation with distributed neutral where a 3-pole Energy MCCB is fitted, it is necessary to measure the neutral voltage to guarantee accurate measurements.

Neutral sensor port exists only on 3P Energy MCCBs. In order to guarantee a high accuracy on measurement it is necessary to connect the neutral conductor to the NSP port using the voltage tap cable (HTC160H).

	LSnl	LSI	LSIG	Energy	
				3P	4P
MIP connector	x	x	x	x	x
PTA output contact	-	x	x	x	x
NSP port	-	-	-	x	-

Communication Interface Port (CIP)

Each MCCB Energy is fitted with two communication interface ports.

The ports are used to connect the panel display or the COM module.

Moreover, this port can be used to supply the Energy MCCB with 24V DC in condition to sustain from using one of the two accessories mentioned above.

	CIP x 2	ZSI ₁	ZSI ₂	ACP	OAC
	COM Module Panel display	Zone selective interlocking		AX/AL Energy	Alarm assignement
P160 Energy	X	-	X	X	X
P250 Energy	X	X	X	X	X
P630 Energy	X	X	X	X	X

h3+ Configuration tool

The h3+ Configuration tool is an expert use of the h3+ electronic trip units.

It is helpful for advanced monitoring, configuration, and diagnostic of the Energy MCCB. The user is also able to launch a tripping test of all h3+ electronic MCCBs.

The h3+ Configuration tool HTP610H is a configuration device and a set of accessories to plug on the MIP Connector which is fitted on all h3+ LSnl, LSI, LSIG and Energy MCCBs. Using this MIP connector, the user is able to be connected to the MCCB thanks to the Configuration tool HTP610H.

Functionalities:

- Monitoring of the MCCB status (only Energy MCCB)
- Monitoring all the measurements
- MCCB Protection and Measurement settings (only Energy MCCB)
- Alarm management (predefined and custom alarms, OAC assignment (only Energy MCCB)
- Tripping Curve test (auto, semi-auto, manual)
- Testing of communication terminals (OAC, PTA, ZSI), (ZSI, OAC only Energy MCCB)
- Maintenance indicators (operation and trip counters, Last trip event ...), (only Energy MCCB)
- History table (only on Energy MCCB)



h3+ Configuration tool



h3+ Configuration tool with tablet

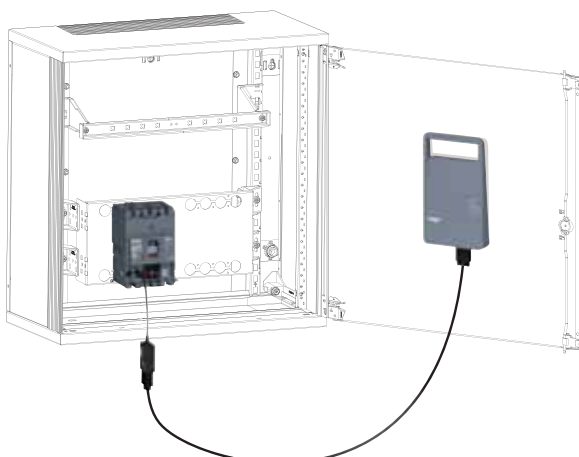

h3+ Configuration tool mounted on panel door

h3+ web server access via Wi-Fi or Ethernet connection

Once plugged on the MIP connector, the user can monitor the h3+ electronic MCCBs via the h3+ web server embedded in the configuration device by a tablet or smartphone Wi-Fi connection.

Note:

The user can also use a wire Ethernet connection with a personal computer to access the h3+ user interface.

The user launches the h3+ user interface by charging its HTTP address in the web-browser of the media (tablet or computer) without downloading an app. The h3+ user interface is compatible with IOS, Android and Windows systems.

Integrated battery to power the h3+ trip units

The h3+ Configuration device is fitted with a battery power supply to ease the monitoring of the MCCBs in cabling workshops or on sites.

On the back of the configuration device a magnet allows to fix it on a metallic panel door.

Thanks to its integrated battery, the h3+ Configuration tool provides the required power to supply the trip unit. That is how the h3+ electronic MCCBs can be tested without switching on the main power supply of the electrical panel board.

Panel display



h3+ Panel display



h3+ Energy MCCB connected to power supply



h3+ Energy MCCB connected via COM module to power supply

The Panel display HTD210H is used as a remote display of the h3+ Energy MCCB. It shows information such as the MCCB status, most measured values, the circuit breaker parameters and events such as trip alarms and custom alarms. In addition to that, modification of the protection settings and modification of the measurement settings are possible. The alarms can also be set-up and activated. This slim device can easily be mounted on a door or a switchboard panel behind the door thanks to the fixing clips provided. Only one accessory cable is necessary to connect the Panel display to the Energy circuit breaker (included 24 V DC supply). The front of the device is protected with a transparent cover in order to achieve a protection of IP65 once mounted on an appropriate switchboard. The LCD screen is backlit for very easy reading even under poor ambient lighting.

Mounting and connection

The connection between the MCCB h3+ Energy and the Panel display HTD210H is done using the CIP Adaptor cable. This CIP Adaptor has a RJ9 plug to fit the Panel display and at the other end a connector adapted to fit in the MCCB.

The external power supply must be Safety Extra Low Voltage (SELV) type, with galvanic isolation between the power supply input (AC voltage) and the power supply output (DC voltage).

Recommended power supply: HTG911H.

The CIP adaptor cable is not only used to connect the Panel display and the MCCB together but also to connect the COM module and the MCCB together. It is available in different lengths.

CIP Adaptor length	Panel display - MCCB	COM module - MCCB
0.5 m	x	x
1.5 m	x	x
3 m	x	x
5 m	x	x
10 m	x	x

Live mode

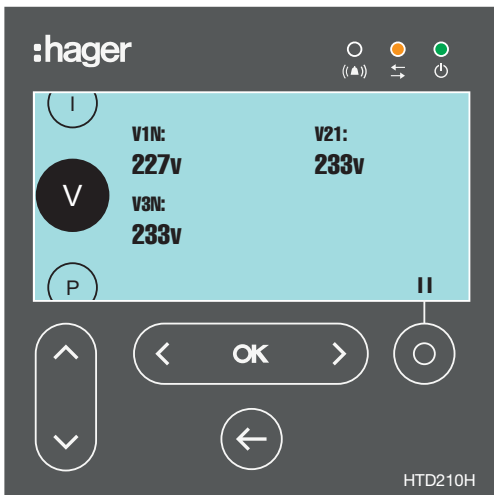

The panel display HTD210H enables a permanent overview of a selection of measured values. In Live mode it can display a continuously a scrolling list of measurements previously selected as favourites.

The Panel display enters in Live mode at the start-up or after two minutes of non-use. The Live mode can also be activated by the navigation.

Alarms and events

All trip alarms or custom alarms are notified by the Panel display. The notification depends on the priority level defined previously at the alarm set-up:

- high priority: a pop-up window displays the time-stamped description of the alarm and the red alarm LED flashes.
- medium priority: the red alarm LED flashes and the description of the alarm can be seen via the contextual alarm menu.
- low priority: no display on the screen.

Moreover, the last saved trip events and alarm events can be seen in event lists.

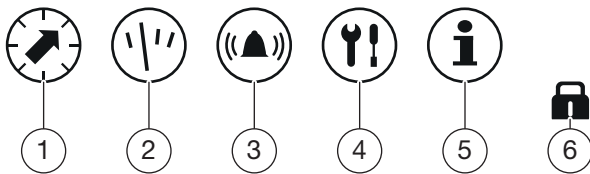

Main menus

- 1 **Protection:** it allows the user to check on the protection parameters and change them if he is allowed to.
- 2 **Measures:** it allows to show most of the values measured by the MCCB.
- 3 **Alarms:** it allows to configure all the alarms, the PTA output contact and the OAC output contact.
- 4 **Configuration:** it allows to configure the measurement settings and the display settings.
- 5 **Information:** status and identification information of the MCCB, list of events.
- 6 **Lock menu**



- 1 Up and down keys
- 2 Left; OK; Right key
- 3 Back key
- 4 Contextual key

Navigation

The navigation through the menus is done using seven touch keys on the front.

The contextual key may be used to unlock the modification of the settings, to pause the scrolling in Live mode, to select the measurements as favourite and to view the current alarms.

At first power on, the user can select the display language (English, Chinese, French, German, Italian, Spanish, Portuguese).

Technical characteristics

- Dimensions: 97 x 97 x 46 mm (27 mm behind the door)
- Panel/Door cut-out: 92 x 92 mm
- Screen dimension: 37 x 78 mm
- Azurin Backlighting
- Alarm LED: red blinking
- Communication LED: yellow blinking
- Power LED: green
- Consumption: 85 mA
- Operating temperature range -10 °C...+55 °C
- Installation category III
- IP rating of front side IP65 (back side IP20)
- Rated supply voltage: DC 24 V (+/- 30 %)

Modbus communication

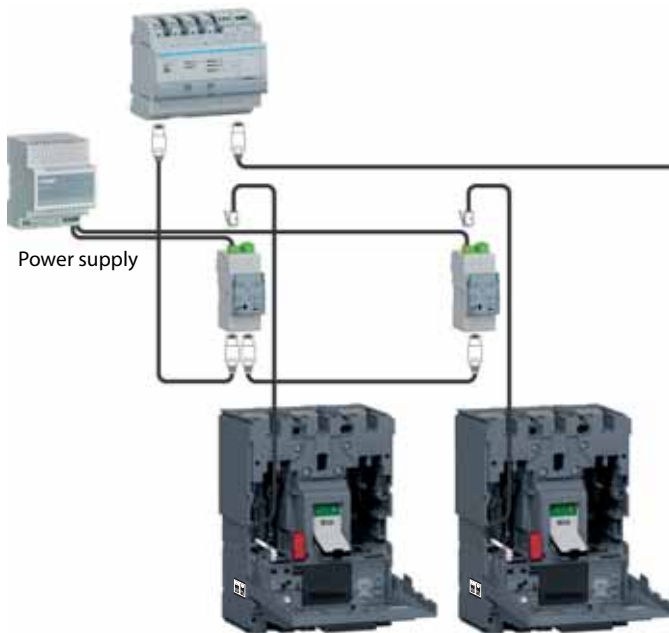

h3+ Energy MCCBs connected to a modbus communication network

The h3+ Energy MCCB can be connected to a modbus communication network via the COM module. Thanks to the prewired RJ45 modbus cable adaptors and to the prewired CIP Adaptor, the connection of Energy MCCBs into a modbus communication environment has become easier.

As a result, it is easy to achieve quickly a modbus daisy chain connection between the Hager COM module and any Modbus network.

Each COM module can be connected to one MCCB h3+ Energy.



COM module HTC310H

COM module HTC320H

COM module

The COM module HTC310H or HTC320H is a modbus RTU interface with modbus address adjustable from 1 to 99 by mean of 2 dials. Baud speed and parity are also adjustable via dials. An embedded 120 Ω termination impedance can be activated via a switch on the device.

Integrated digital inputs and outputs

Compared to the basic COM module HTC310H, the HTC320H is a COM module with two 24 V DC inputs and two 24/48 V DC outputs which can be controlled via Modbus communication.

For instance, the 2 inputs can be used to pass the pre-trip alarm and trip contacts of the RCD add-on block to upper level of supervision.

The 2 outputs can be used to drive the command of the motor operator accessory and achieve a remote ON/OFF operation of the Energy MCCB through Modbus communication.

Technical characteristics

- Width: 2 modules
- Digital Inputs: typical 24 V DC 15 – 30 V DC), 2 mA - 15 mA, minimum on state duration 50 ms, 5-pins connector at the top of the device (wires from 0.5 to 1.5 mm²)
- Digital Output: - ≤ 100 V DC (typical 24, 48 V DC), 10 μA - 50 mA, Pulse mini 100 ms, mini period 1 s, 10 ms delay, - 4-pins connector on the bottom of the device (wires from 0.5 to 1.5 mm²)
- Module consumption: 40 mA / 24 V DC
- Supply voltage: 24 V DC (+/- 30%).

Mounting of COM module



The COM module can be mounted on a DIN rail or at the side of the MCCB thanks to the side support.

One piece of side support is delivered with the COM module to allow fixing the COM module at the side of the MCCB. It can also be used to guide the cables and wires coming from inside the MCCB such as the CIP Adaptor cable between the circuit breaker and the COM module or between the circuit breaker and the Panel display.

It is also useful to guide the outgoing auxiliary wires in case of use AX/AL Energy.

The COM module has a screw terminal on the top to connect a 24 V DC power supply in order to operate properly. This 24 V power supply is conveyed to the MCCB via the CIP Adaptor connected between the COM module and the MCCB.

Two RJ45 terminals on the bottom of the device facilitate daisy chain connection as part of a Modbus RTU network.

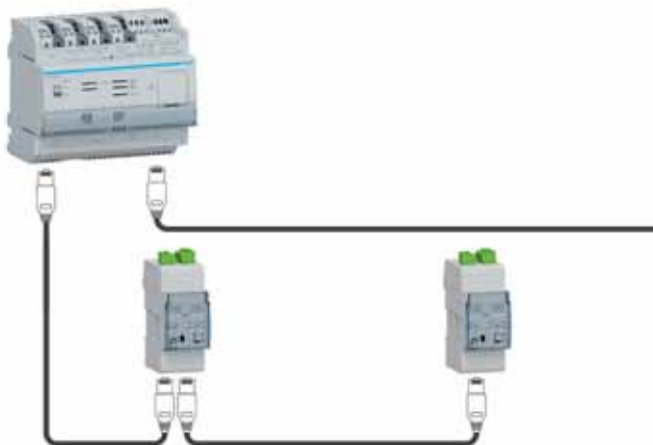

COM Modules with modbus cables

Connection accessories

Different lengths and types of prewired RJ45 modbus conductors are available to make the installation easier even if the conductor shield has to be connected as close as possible to a protective ground.

Prewired modbus cable RJ45 – RJ45	Prewired modbus cable RJ45 – RJ45 with earth	Prewired modbus cable Wire – RJ45 with earth
0.2 m	-	-
1 m	1 m	-
2 m	2 m	-
-	-	3 m
5 m	5 m	-



CIP adaptor cables

The communication between the MCCB h3+ Energy and the COM module is done using the CIP adaptor cable. It is available in different lengths.

CIP Adaptor length	Panel display - MCCB	COM module - MCCB
0.5 m	x	x
1.5 m	x	x
3 m	x	x
5 m	x	x
10 m	x	x

AX/AL Energy



AX/AL Energy auxiliary module

The optional AX/AL Energy auxiliary module is used to communicate the ON/OFF mechanical status of the MCCB to the Energy trip unit. It also includes an operation cycle counter and a trip fault cycle counter to acquire the number of operation cycles and the number of trip fault cycles in the Energy trip unit.

These status and numbers can then be displayed on the embedded display of MCCB or on the optional HTD210H Panel display and they are also available via modbus communication.

The counters can be used as maintenance indicators with Configuration tool HTP610H:

- Mechanical operation cycle counter.
- Mechanical and electrical trip fault cycle counter.

The optional AX/AL Energy auxiliary module is recommended to provide remote AX and AL indication on auxiliary circuits such as warning light, electrical locking, relays, etc. It includes AX NO or NC contacts and AL NO or NC contacts.

AX contacts indicate the position Open/Closed of the circuit breaker contacts.

AL contacts indicate that the circuit breaker has tripped due to:

- An electrical fault (overload, short circuit).
- The operation of a shunt trip release or an undervoltage release.
- The “push-to-trip” button operation.

The optional AX/AL Energy auxiliary module has a dedicated location behind the front cover of the circuit breaker and a dedicated ACP terminal in the circuit breaker. Its presence is visible from the front facet through AX or AL windows.

It is available in three versions:

- only counter
- counter and AX/AL 250 V AC 2 m prewired contacts
- counter and AX/AL 125 V AC (low level) 2 m prewired contacts

Prewired contact: 0.34 mm² wires.

Electrical characteristics

Nominal current for 250 V AC AX/AL:

- 250 V / AC-14 = 3 A
- 250 V / AC-15 = 1 A
- 125 V / DC-12 = 0.4 A

Nominal current for 125 V AC AX/AL (low level):

- 125 V / AC-14 = 0.1 A
- 30 V / DC-12 = 0.1 A



AX/AL window

Switch-disconnector range

Page

01 Presentation

66

Presentation

The h3+ Switch-disconnectors comply with the IEC60947-1 and IEC 60947-3 standards. They are mainly used in electrical distribution applications such as:

- isolation and coupling of busbars
- isolation of main and sub-distribution boards
- isolation of local enclosures
- isolation of final distribution enclosures for commercial and industrial applications

The h3+ Switch-disconnectors are compatible with the following standard accessories of the h3+ MCCB range:

- motor operators
- direct and external rotary operators
- plug-in and withdrawable systems
- internal accessories: AX, AL, SHT and UVR
- terminal protections
- terminal extensions and cable terminals
- interlocking systems



Switch-disconnector protection

The h3+ Switch-disconnector is suitable to switch ON and OFF loads operating according to the utilisation category AC 22A / AC 23A in 415 V and DC 22A / DC 23A in 250 V. In addition to that, they ensure the complete disconnection of the load. Moreover, the disconnection can be assured by a padlocking element fitted onto the Switch-disconnector. As for the protection against overload and short-circuit, it must be done by an upstream device, in compliance with installation standards.

Switch-disconnectors				P160		P250		P630		
Number of poles				3, 4		3, 4		3, 4		
General characteristics										
Nominal current				125	160	200	250	400	630	
Operational current	I _e	[A]	AC22A	220/240 V AC	125	160	200	250	400	630
				380/415V AC	125	160	200	250	400	630
				660/690V AC	125	160	200	250	400	630
			AC23A	220/240 V AC	125	160	200	250	400	500
				380/415V AC	125	160	200	250	400	500
				660/690V AC	125	160	200	250	400	500
			DC23A	125 V DC 1P	125	160	200	250	400	630
				250 V DC 2P	125	160	200	250	400	630
				375 V DC 3P	125	160	200	250	400	630
				500 V DC 4P	125	160	200	250	400	630
Short-circuit making capacity @ 380-415 V AC	I _{cm}	[kA] peak		2.8	2.8	5	5	7.6	13	
Short time withstand current	I _{cw}	[kA]	1 s	2	2	3.6	3.6	5	7.6	
Operational voltage, (AC)	U _e	[V]		690						
Frequency	f	[Hz]		50 / 60						
Rated insulation voltage	U _i	[V]		800						
Impulse withstand voltage	U _{imp}	[kV]		8						
Suitability for isolation				yes						
Pollution degree				3						
Mechanical endurance in number of operations				20000	20000	20000	20000	30000	30000	
Electric endurance in number of cycles	I _n		440 V AC	10000	10000	10000	10000	6000	4000	
			690 V AC	1500	1500	1500	1500	1000	1000	
			500 V DC	1500	1500	1500	1500	1500	1500	
			500 V DC	1000	1000	1000	1000	1000	1000	
Dimensions										
Height		(mm)		130	165	260				
Width	3P	(mm)		90	105	140				
	4P	(mm)		120	140	185				
Depth				97	97	150				
Weight	3P	(kg)		0.97	1.05	4.8				
	4P	(kg)		1.32	1.91	6.4				

Accessories

	Page
01 Overview	70
02 Earth leakage protection	72
03 Connection accessories	74
04 Insulation accessories	77
05 Auxiliaries	81
06 Mounting types	86
07 Handles and motor operators	92
08 Locking and sealing accessories	95
09 Interlocking accessories	98

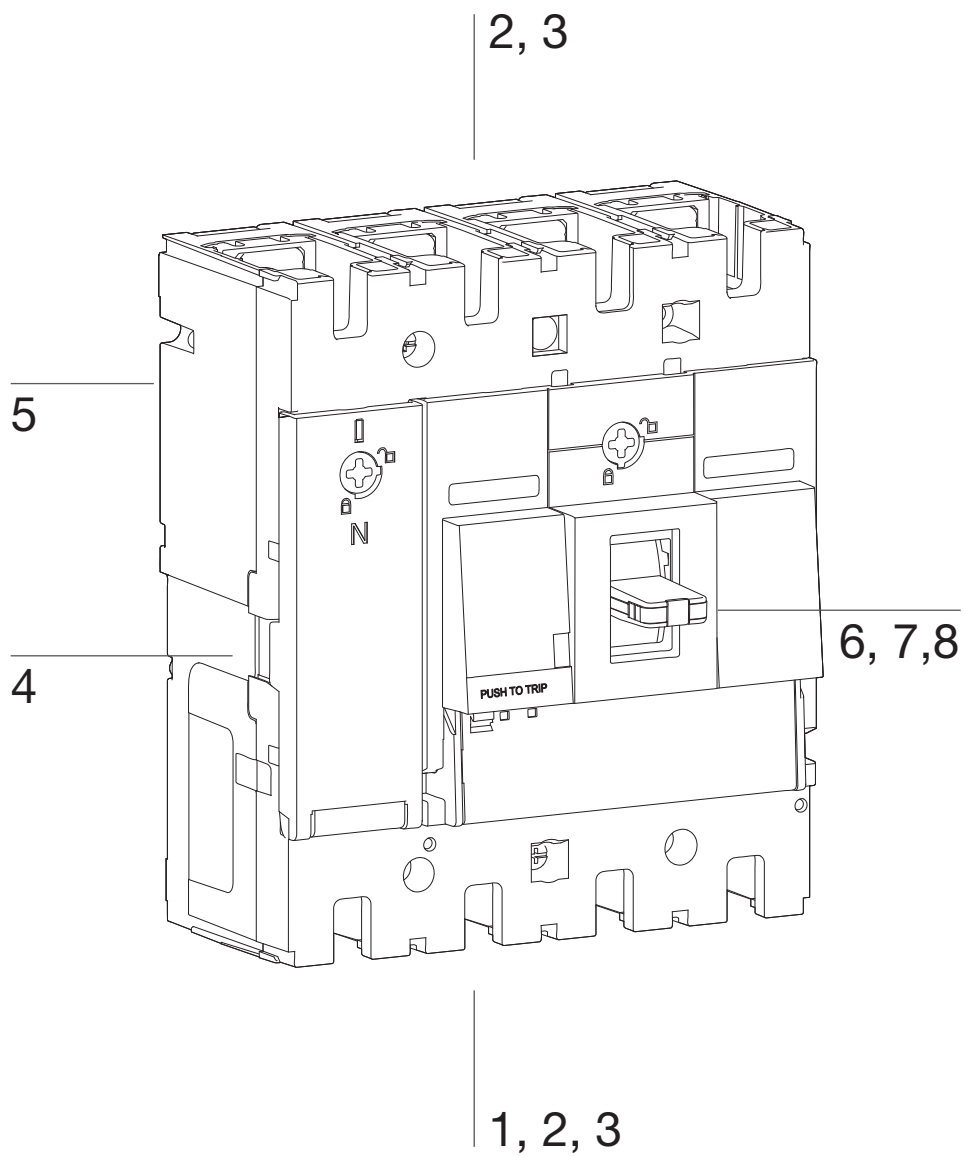

1. Earth leakage protection

RCD add-on block
page 72

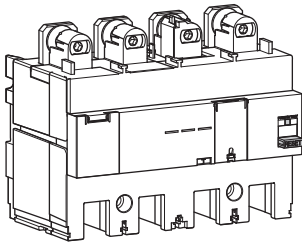

2. Connection accessories

Straight and spread bar extensions
page 76

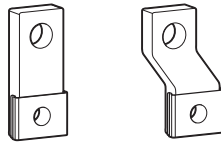

External cable terminals
page 76

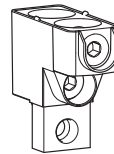

Rear connection
page 76

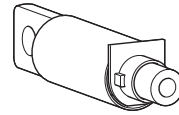

3. Connection insulation

Straight
page 79

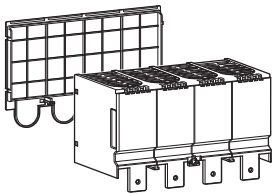

Spreader
page 79

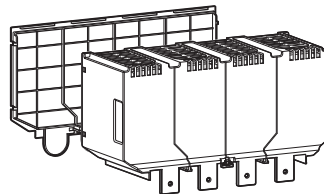

Rear and Plug-in
page 80

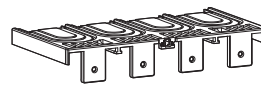

4. Auxiliaries
page 81

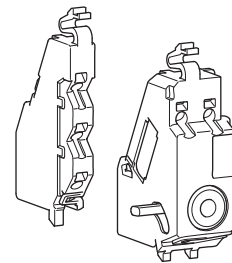

5. Mounting types

Plug-in
page 87

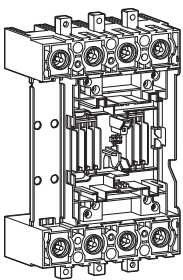

Withdrawable
page 90

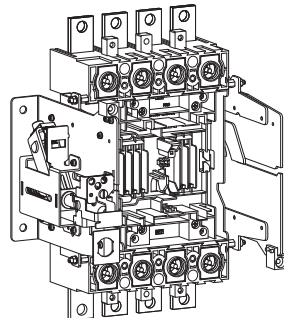

6. Interlocking accessories

Link interlock
page 98

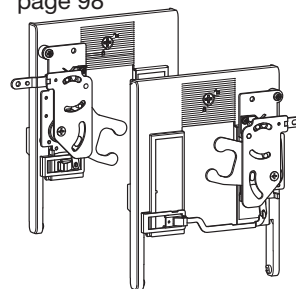

Cable interlock
page 98

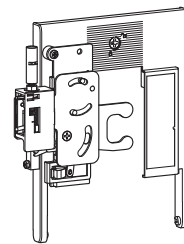

7. Handles and motor operators

Direct rotary handle
page 92

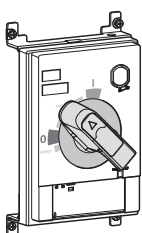

On door rotary handle
page 92

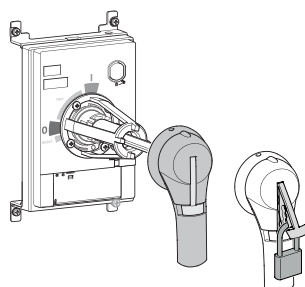

Motor operator
page 93

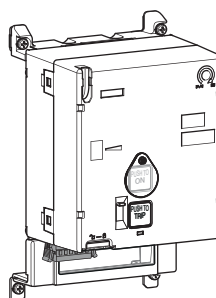

8. Locking and sealing accessories

Padlock accessories
page 95



Key lock
page 96



RCD add-on block



h3+ P250 combined with RCD add-on block

The earth leakage protection is ensured by the RCD add-on block, which is mounted directly under the MCCB. The RCD add-on block directly commands the tripping mechanism of the circuit breaker mechanically (except the alarm-only version). The RCD add-on block requires connecting at least two phases in order to be supplied.

A test button exists on the front side of the product to allow testing the mechanical link between the MCCB and the RCD underneath no external power source. The RCD add-on block is available for the P250 and P630 circuit breakers.

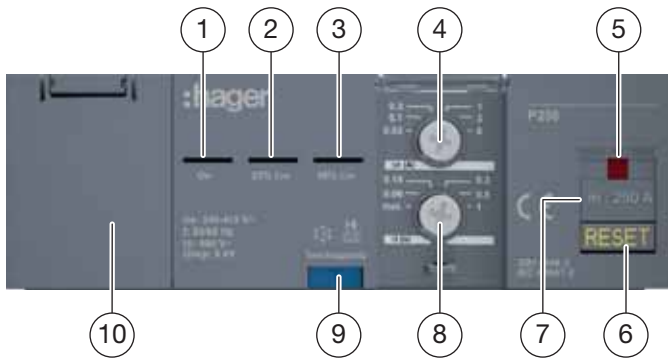

- ① On LED: Green when the RCD add-on block is ready to protect against earth leakage fault.
- ② 25 % IΔn LED: Orange when the earth leakage fault detected is greater than 25 % of the IΔn already set.
- ③ 50 % IΔn LED: Red when the earth leakage fault detected is greater than 50 % of the IΔn already set.
- ④ IΔn Sensitivity dial
- ⑤ Push to test button for the test of the mechanical link between the RCD add-on block and the circuit breaker.
- ⑥ Reset button: Resets the RCD add-on block so it can be operational again after trip ping due an earth leakage fault.
- ⑦ Rating indication.
- ⑧ IΔt time delay dial.
- ⑨ Test button simulating an earth-fault for regular check-up on the tripping function.
- ⑩ Housing of the RCD auxiliary contacts.

Three versions of RCD add-on block are available:

Frame	Rating	RCD versions			Settings	
		Fixed	Adjustable	Alarm	Rated I Δ n (A)	Time delay Δ t (s)
P250	100 A	x	x	x	0.03 - 0.1 - 0.3 - 1 - 3 - 6	inst - 0.06 - 0.15 - 0.3 - 0.5 - 1
	160 A	x	x	x		
	250 A	-	x	x		
P630	400 A	-	x	x	0.1 - 0.3 - 0.5 - 1.3 - 10	inst - 0.1 - 0.3 - 0.5 - 1 - 3
	630 A		x	x		

For fixed RCD versions of P250, rated I Δ n is fixed at 0,03A and time delay Δ t (s) is instantaneous.

Characteristics

Frequency	50/60 Hz
U _i	690 V
U _{imp}	6 kV
Nb of poles	4P
Ph-ph voltage U _e	220-415 V~
RCD type	A for I Δ n \leq 6 AC for I Δ n =10

RCD auxiliary contacts

Two auxiliary contacts are available at the front of the product and protected by a cover. They are available for two versions: adjustable and alarm only.

RCD Add-on block

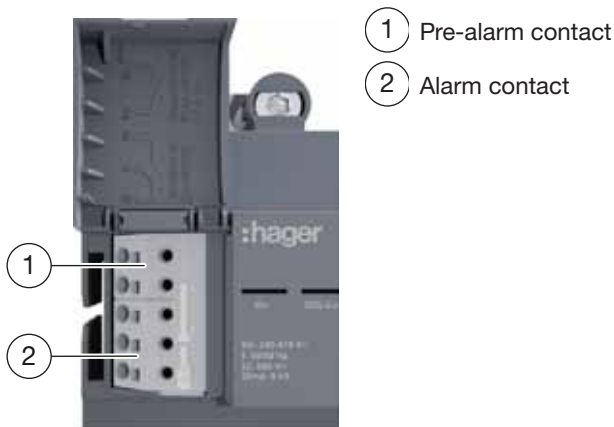

Auxiliary terminals on RCD add-on block

Auxiliary contacts	Pre-alarm	Alarm
Type	1NO	1NO.NC
Maximum current for AC voltage	70 mA 250 V~	3 A 250 V~
Maximum current for DC voltage	70 mA 48 V DC	2 A 48 V DC
Type of wire	rigid or flexible	rigid or flexible
Maximum cross section	1.5 mm ²	1.5 mm ²

Protection can also be ensured by the combination of a residual current relay and an external core balanced transformer.

Connection accessories

The h3+ circuit breakers are delivered with or without cable terminals depending on the chosen version:

- with cable terminal
- with front connection

P160 MCCB are available in both versions and P250 and P630 are available only with front connection (without cable terminals).

P160 MCCB with cage connections (CTC)

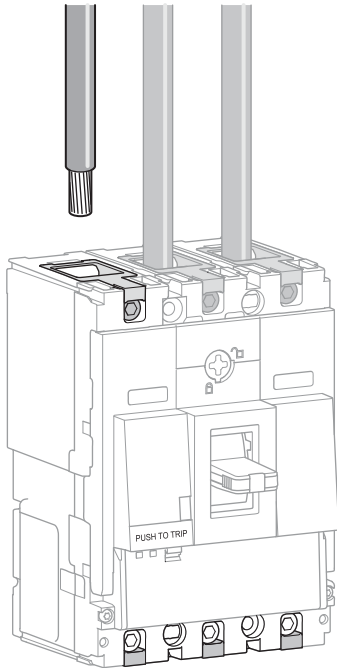

Cable connection

Connection accessories are available to adapt the circuit breaker for bare cables, bars or rear connections. Spreader and external multi-cable terminals are also available.

The h3+ circuit breaker versions with cable terminals are delivered with terminals compatible for bare cables, straight and bar extensions.

Bars and lugs dimensions

Cross section rigid / flexible (mm ²)	Tightening torque (Nm)
6...95	6
6...70	6

Tightening of bars or cables with lugs to the following tightening torque specifications:

The integrated cable terminals can be removed. The MCCB could then also be used with bars or lugs. In this case M8 screws are needed.

MCCB with front connections (FTC)

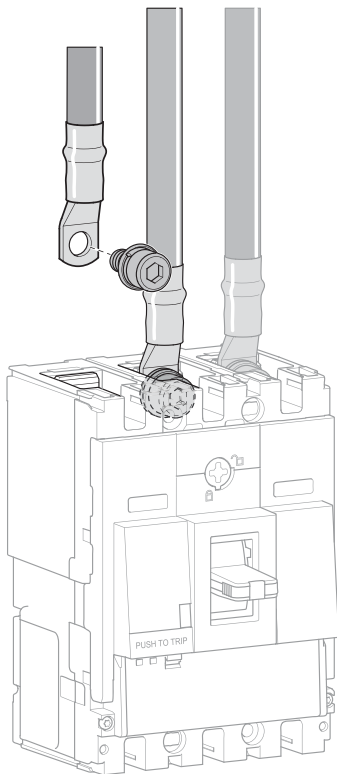

Front connection

The h3+ circuit breakers versions with front connections are delivered with M8 screws for P160 - P630 and M6 screws for P250. Thus, cables fitted with lugs or bars can be connected.

Connection of bars or cables with lugs

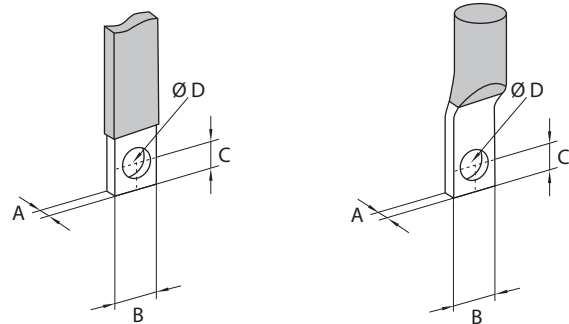

Copper bar and lug

Lugs used for cable connection or bars have to match the following dimensions:

Bars and lugs dimensions

(mm)	A	B	C	ØD
P160	0.8...4	max 21	9.8	8.5
P250	1.2...4	max 25	11	8.5
P630	1.2...12	max 32	11	10

Tightening of bars or cables with lugs to the following tightening torque specifications:

Bars or cables tightening torques

P160	6 Nm
P250	12 Nm
P630	18 Nm

Interphase barriers or terminal covers are recommended. They are mandatory in some cases. 2 or 3 (for 4P) interphase barriers are delivered with the circuit breaker. They are compatible with the external cable terminals. Interphase barriers are also separately available.

External cable terminals

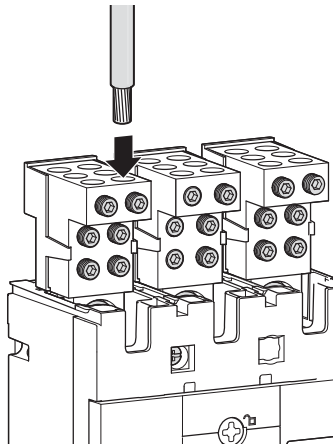

6 wires cable terminal P160

The external cable terminals are screwed directly into the terminals of the circuit breakers. They are made of aluminum and are suitable for Cu or Al wires. 2 or 3 (for 4P) interphase barriers are delivered with the circuit breaker. They are compatible with the external cable terminals. Insulation accessories may be required. Please refer to “Insulation accessories” on page 77.

External cable terminals Cu/Al P160

	Cross section rigid/flexible	Tightening torque
1 wire	35...120 mm ² 35...95 mm ²	25 Nm
6 wires	4...25 mm ² 4...16 mm ²	3 Nm

External cable terminals Cu/Al P250

	Cross section rigid/flexible	Tightening torque
1 wire	50...185 mm ² 50...185 mm ²	25 Nm
2 wires	35...120 mm ² 35...95 mm ²	25 Nm
6 wires	6...35 mm ² 6...35 mm ²	6 Nm

External cable terminals Cu/Al P630

	Cross section rigid/flexible	Tightening torque
1 wire	35...300 mm ² 35...300 mm ²	25 Nm
2 wires	35...300 mm ² 35...300 mm ²	25 Nm

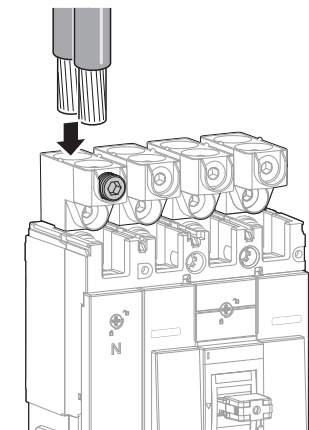

2 wires cable terminal P630

Rear connection

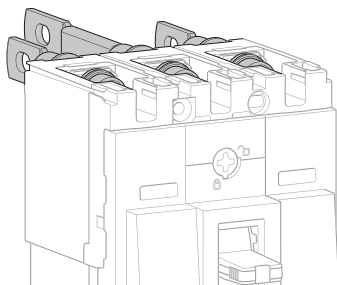

Rear connection P160

The h3+ circuit breakers can be fitted with rear connections. Rear connections are suitable for bars or cables with lugs. Bars may be positioned horizontally, vertically or at a 45° angle. The rear connections are directly screwed to the device connection terminals.

Straight and spread bar extensions

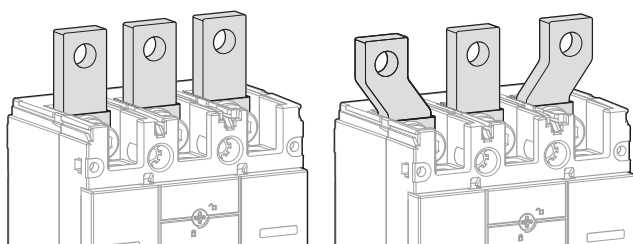









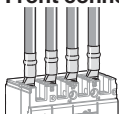

Bar extensions for P630

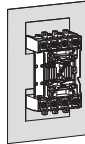
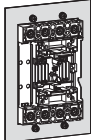
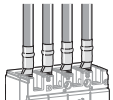
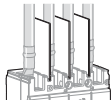
Straight bar extensions and spreader extensions are available separately with P160 (FTC / CTC) - P250 - P630 MCCBs. Spreader extensions are mainly used to increase the pitch of the MCCBs. Insulation accessories such as interphase barriers or terminal covers with insulation plates may be required. Please refer to “Insulation accessories” on page 77.

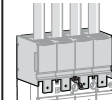

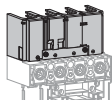
Insulation accessories

Insulation accessories may be required or even mandatory in some cases. This table gives the rules to be respected to ensure the insulation of the live parts around the h3+ circuit breakers.

	Front connection				Rear connection	Plug-in or withdrawable on back plate	Plug-in flush-mounted	
								
Accessories	No insulation accessory	Interphase barriers	Earth plate	Terminal covers	Terminal covers for rear connections	Terminal covers for MCCB	Terminal covers for plug-in base	Terminal covers for MCCB
								

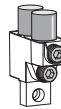

For operating voltage ≤ 500 VAC

Type of conductor

	Insulated bars or cables	Possible	Possible	Possible	Possible	-	-	-	-
	Non insulated bars or ring lugs	No	Mandatory *	Possible	Mandatory for IP20 *	Recommended	Mandatory	Mandatory	Mandatory
	Extension terminals	No	Mandatory *	Possible	Mandatory for IP20 *	-	-	-	-
	Cables with external cable terminals	No	Mandatory *	Mandatory	Mandatory for IP20 *	-	-	-	-

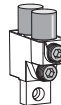

For operating voltage > 500 VAC

Type of conductor

	Insulated bars or cables	No	Mandatory *	Possible for P160-P250 Mandatory for P630	Possible	-	-	-	-
	Non insulated bars or ring lugs	No	Mandatory *	Possible for P160-P250 Mandatory for P630	Mandatory for IP20 *	Mandatory	Mandatory	Mandatory	Mandatory
	Extension terminals	No	Mandatory *	Possible for P160-P250 Mandatory for P630	Mandatory for IP20 *	-	-	-	-
	Cables with external cable terminals	No	Mandatory *	Mandatory	Mandatory for IP20 *	-	-	-	-

* fitted on top only if direct feeding / fitted on top and bottom if reverse feeding

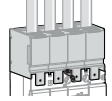
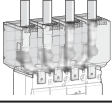
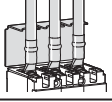
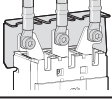
Connection and compatibility chart

	Collar terminal	Straight terminal extension	Spreader terminal extension	Rear connection	L connection
Terminal covers for straight connections 	<input checked="" type="checkbox"/>	<input checked="" type="checkbox"/>	-	-	-
Terminal covers for extended spreader 	-	-	<input checked="" type="checkbox"/>	-	-
Earth plates for straight terminal covers 	<input checked="" type="checkbox"/>	<input checked="" type="checkbox"/>	-	-	-
Earth plates for spreader terminal covers 	-	-	<input checked="" type="checkbox"/>	-	-
Terminal covers for rear connection or lug-in 	-	-	-	<input checked="" type="checkbox"/>	<input checked="" type="checkbox"/>
Interphase barriers 	<input checked="" type="checkbox"/>	<input checked="" type="checkbox"/>	<input checked="" type="checkbox"/>	-	-

Interphase barriers

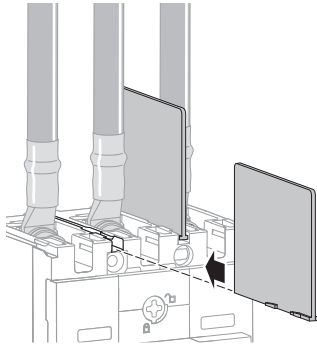

Interphase barriers P160

4 (for 3P) or 6 (for 4P) interphase barriers are delivered with the MCCB. They are compatible with the external cable terminals. Interphase barriers are also separately available.

Straight terminal covers

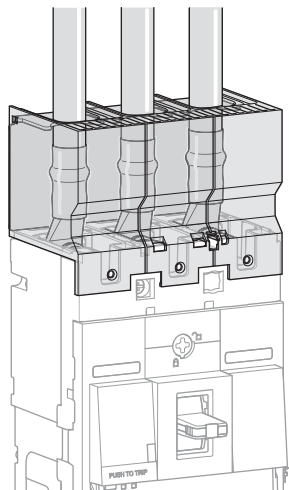

Straight cover

P160, P250 and P630 MCCBs can be fitted with straight terminal covers when used with cables with lugs or straight bars. The straight terminal covers provide internal separation between phases. They are available in one size for both the P160, P250 and P630 circuit breakers.

Spreader terminal covers

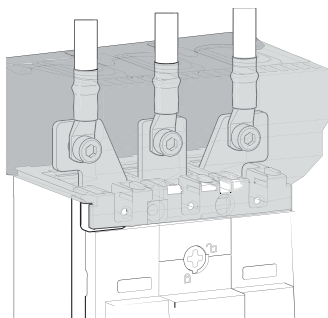

Spreader cover

P160, P250 and P630 MCCs can be fitted with spreader terminal covers when spreader extensions are fitted. They ensure an insulation between phases too.

Insulation plates

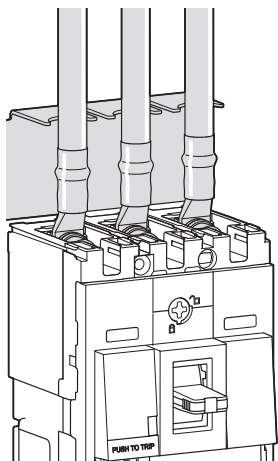

Insulation plate

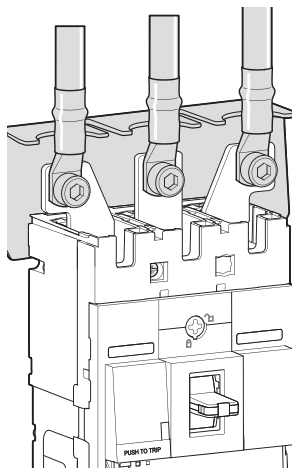

Insulation plate for spreaders

Rear insulation plates provide complete insulation of the connections from the back.

Front covers for rear and plug-in connections

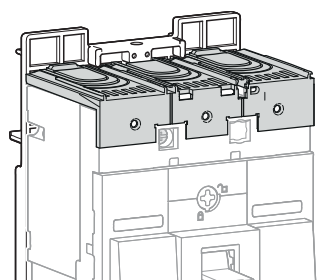

Front cover

P160, P250 and P630 circuit breakers can be fitted with terminal covers to ensure insulation on front connections in case of use when rear connections or plug-in are fitted.

These covers provide an IP40 protection degree. They can be mounted after the circuit breaker's installation on a back plate or a DIN rail. They are sealable.

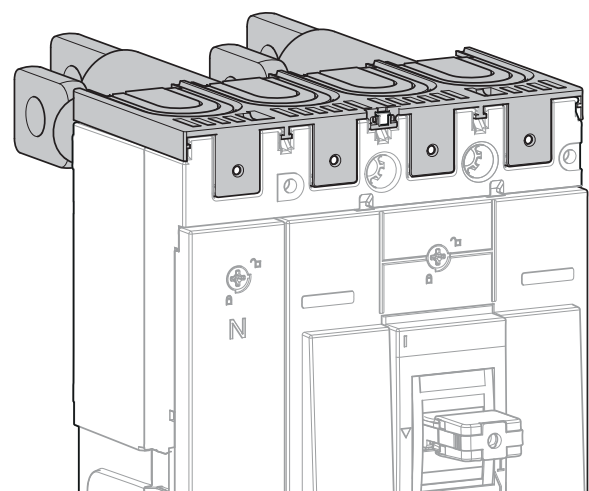

Front cover

Selection of auxiliaries

All MCCBs share the same internal auxiliaries. The installation of the auxiliaries is simple and does not require any specific tool.

P160-P250 and P630 MCCBs have internal locations dedicated to the mounting of the following electrical auxiliaries.

P160

- 1 AX ON/OFF
- 1 AL trip indication
- 1 UVR / UVR with delay or 1 SHT

P250

- 2 AX ON/OFF
- 1 AL trip indication
- 1 UVR / UVR with delay or 1 SHT

P630

- 4 AX ON/OFF
- 2 AL trip indication
- 1 UVR / UVR with delay or 1 SHT

Location of auxiliaries P160 - P250

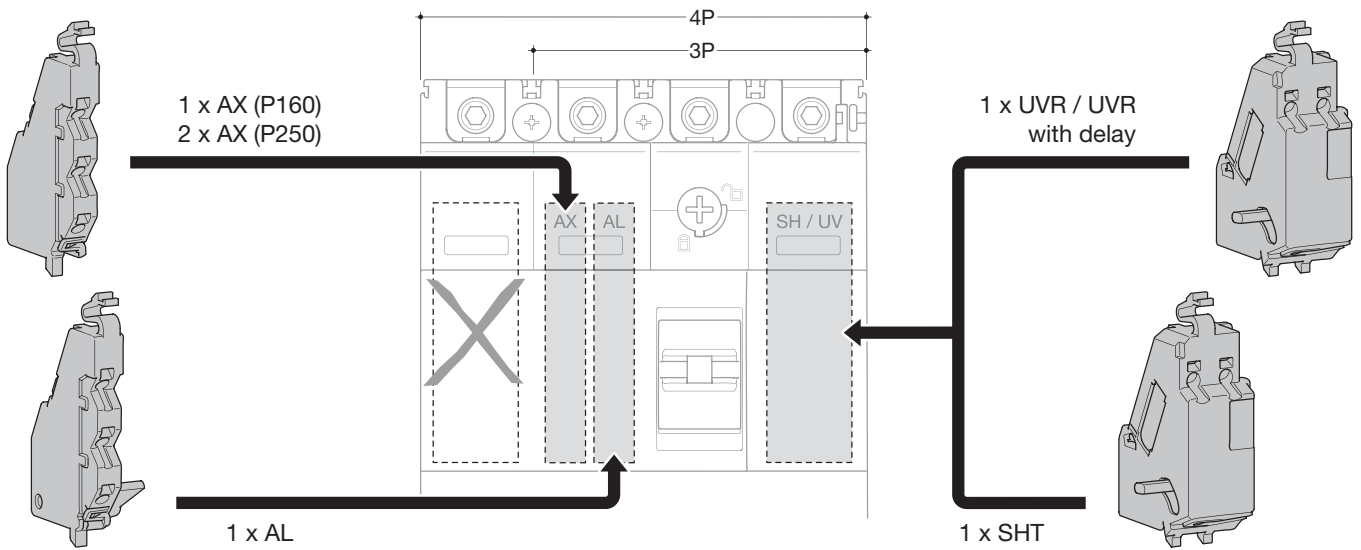

Location of auxiliaries P630

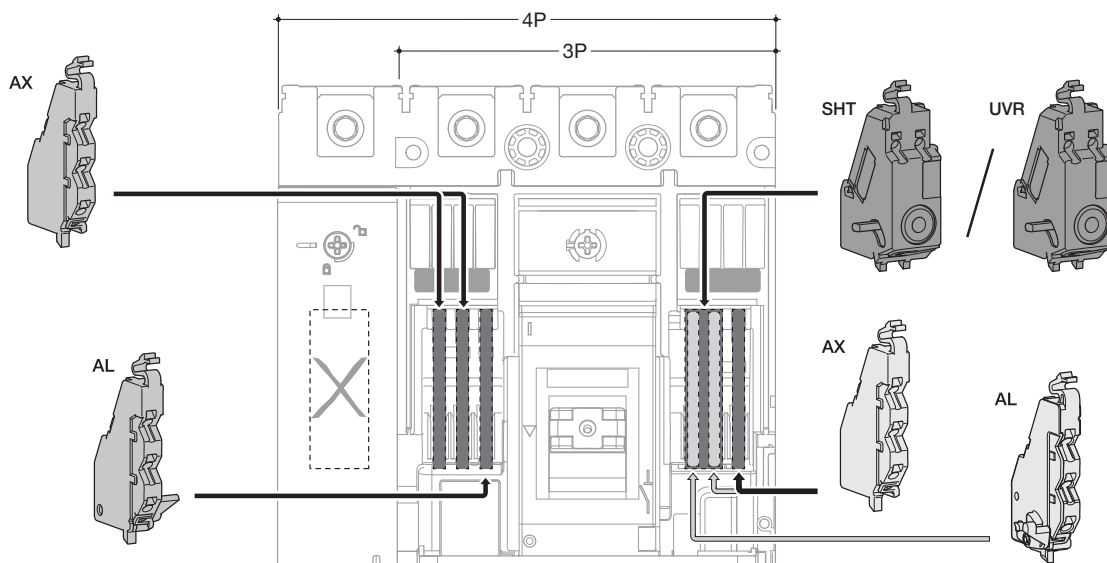

Connection of auxiliaries

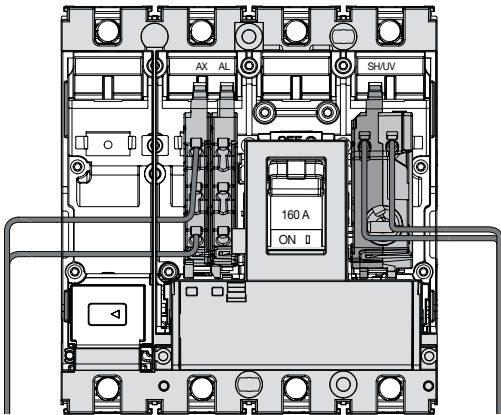

Auxiliary cabling on TM MCCB

contacts (AX or AL), shunt trip releases SHT or undervoltage releases UVR. These auxiliaries are fitted with spring terminals. It is recommended to route the wires from the inside to the outside of the circuit breaker, under the front auxiliary cover, in the following way.

The AX/AL - Energy dedicated to the Energy MCCB is fitted with prewired contacts.

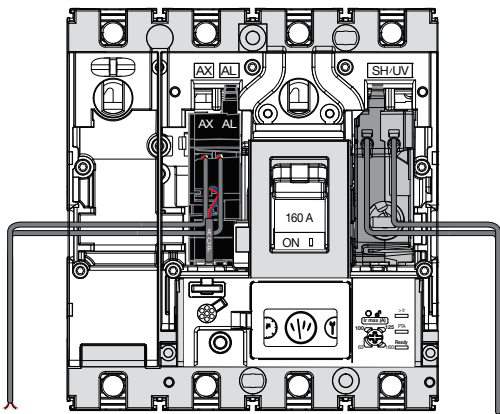

Auxiliary cabling on Energy MCCB

The maximum wire cross section is 1.25 mm² for auxiliary

AX auxiliary and AL alarm indication contacts

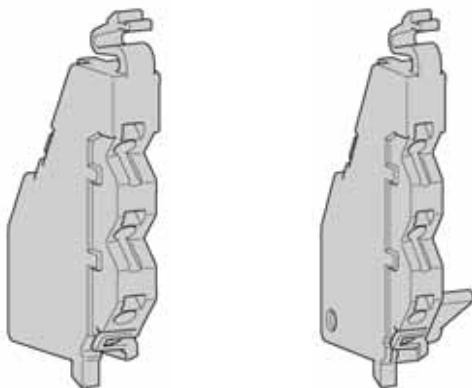

AX auxiliary

AL auxiliary

Indication contacts provide remote information of the circuit breaker status and can thus be used for indications, electrical locking, relays, etc. They are NO.NC contacts.

AX contacts indicate the position Open/Closed of the circuit breaker contacts.

AL contacts indicate that the circuit breaker has tripped due to:

- An electrical fault (overload, short circuit).
- The operation of a shunt trip release or an undervoltage release.
- The “push-to-trip” button operation.

AL contacts reset when the circuit breaker is reset.

Installation and connection



Left side Auxiliary P160

The AX and AL contacts have dedicated locations behind the front cover of the circuit breaker and their presence is visible from the front face through an Auxiliary window.

Each spring terminal may be connected by one 0.5...1.25 mm² flexible or rigid wire.

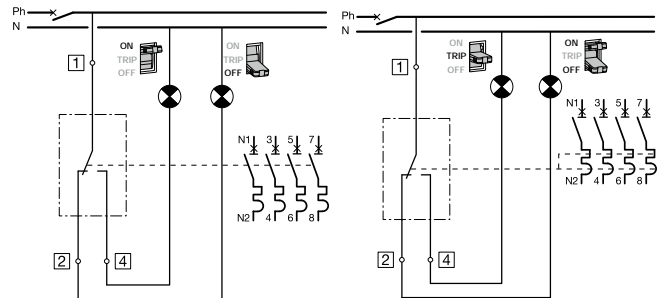

AX auxiliary

AL auxiliary

Electrical characteristics

Operational current for AX and AL:

- 250 V / AC-14 = 3 A
- 250 V / AC-15 = 1 A
- 125 V / DC-12 = 0.4 A

Operational current for low-level AX and AL:

- 30 V / DC-12 = 0.1 A

SHT shunt trip and UVR undervoltage release coils

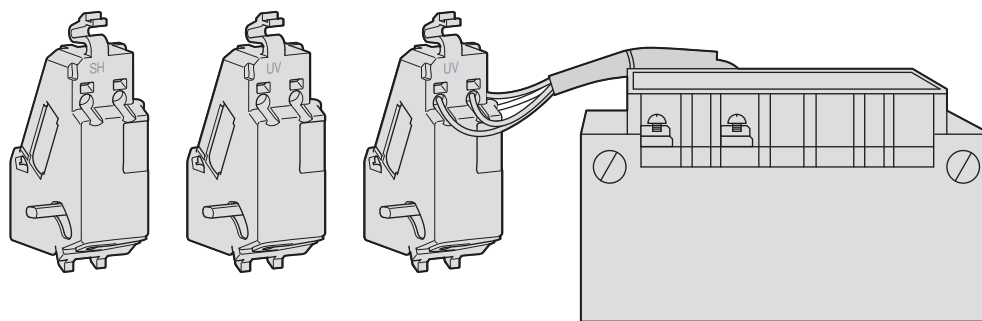

SHT and UVR

A shunt trip or an undervoltage release coil can be used to trip the circuit breaker using a control signal. They are for a remote tripping of the circuit breaker.

A SHT shunt trip release coil trips the circuit breaker when the control voltage rises above 70 % of its rated nominal voltage (Un). It is an impulse signal (> 20 ms) or a maintained control signal.

Shunt trip release 110...130 V~ is suitable for ground-fault protection when combined with a Class I ground-fault sensing element.

A UVR undervoltage release trips the circuit breaker when the control voltage drops below 70 % to 35 % of its rated voltage.

A delayed UVR undervoltage release coil eliminates the risk of nuisance tripping due to a transient drop voltage lasting less than 500 ms. For shorter micro-outages, a system of capacitors provides temporary supply to the UVR at U > 0.7 Un to ensure non tripping.

Electrical characteristics**SHT**

Operating voltage	Un	24 V DC	48 V DC	100-120 V~	200-240 V~	380-450 V~
Operating range		75-125 % Un		85-110 % Un		
Exciting current	mA	30.0	30.0	14.0	14.0	6.50
Power consumption	VA	0.72	1.44	1.68	3.36	2.93
Electrical endurances at 415 V AC	cycles	6000	6000	6000	6000	6000
Mechanical endurances ON/OFF	cycles	15000	15000	15000	15000	15000

UVR

Operating voltage	Un	24 V DC	100-120 V~	200-240 V~	380-450 V~
Closing voltage		> 85 % Un			
Release voltage		70 % Un > ... > 35 % Un			
Opening voltage		< 35 % Un			
Exciting current	mA	23.0	12.0	6.3	5.2
Power consumption	VA	0.56	1.4	1.5	2.3
Electrical endurances at 415 V AC	cycles	6000	6000	6000	6000
Mechanical endurances ON/OFF	cycles	15000	15000	15000	15000

UVR with delay

Operating voltage	Un	24 V DC	110 V~	240 V~	440 V~
Closing voltage		> 85 % Un			
Release voltage		70 % Un > ... > 35 % Un			
Opening voltage		< 35 % Un			
Delay	ms	500			
Exciting current	mA	23.0	12.0	6.3	5.2
Power consumption	VA	0.56	1.4	1.5	2.3
Electrical endurances at 415 V AC	cycles	6000	6000	6000	6000
Mechanical endurances ON/OFF	cycles	15000	15000	15000	15000

Installation and connection



Right side Auxiliary window P160

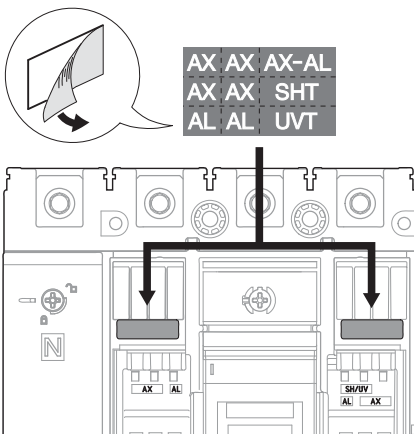

Internal auxiliaries identification on P630

The SHT and UVR releases have dedicated locations behind the front auxiliary cover of the circuit breaker and their presence is visible on the front through an Auxiliary window. On P630 MCCBs, the presence of the internal auxiliaries is identified by a sticker that needs to be placed in a dedicated location behind the auxiliary window. Each spring terminal may be connected by one flexible or rigid cable of 0.5...1.25 mm².

Operation

The circuit breaker must be reset locally after being tripped by the shunt trip or undervoltage release. Tripping by the shunt trip or undervoltage release has priority over manual closing. When a tripping command from a SHT or UVR coil is active, it is not possible to manually operate the circuit breaker and close the main contacts, even temporarily.

SHT and UVR endurance

100 % of the rated mechanical endurance of the circuit breaker.

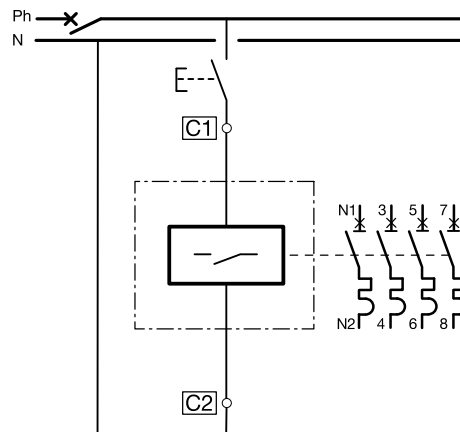

SHT

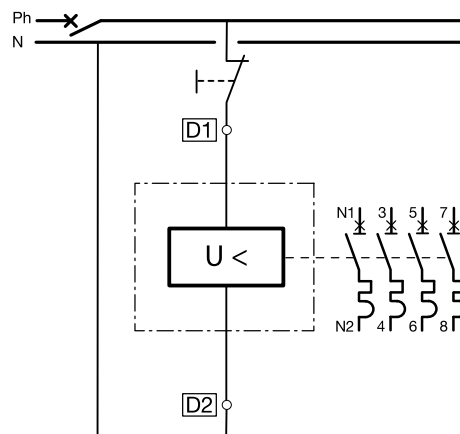

UVR

Fixed on back plate

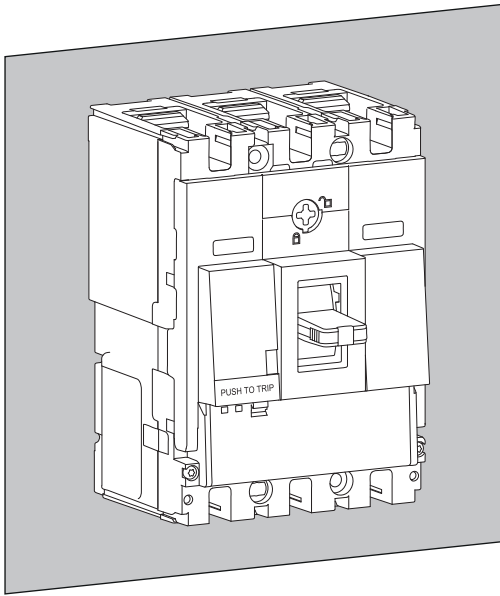

P160 on back plate

P160, P250 and P630 circuit breakers can be mounted as fixed device on a back plate.

DIN rail adaptor

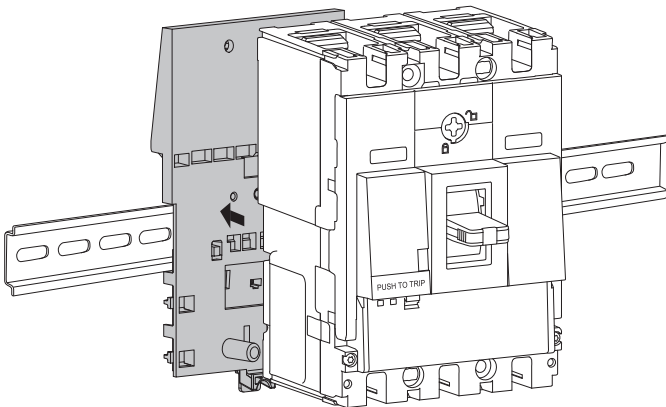

P160 and DIN rail adaptor

If needed, the P160 and the P250 circuit breakers can be mounted on a DIN rail with a specific accessory fitted on the back.

Plug-in system

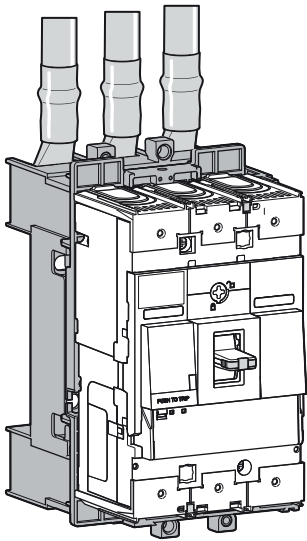

Plug-in for cables fitted with lug P250

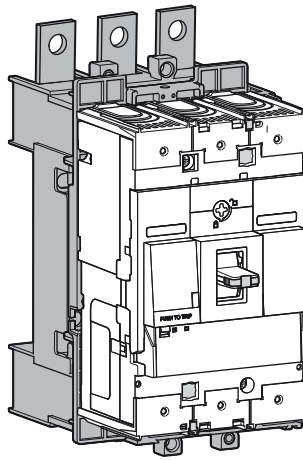

Plug-in with front terminal P250

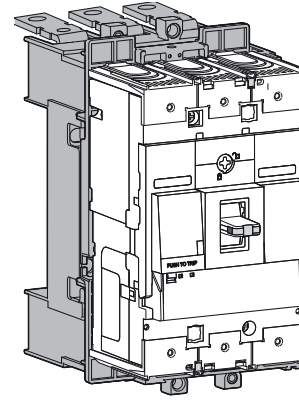

Plug-in with rear terminal P250

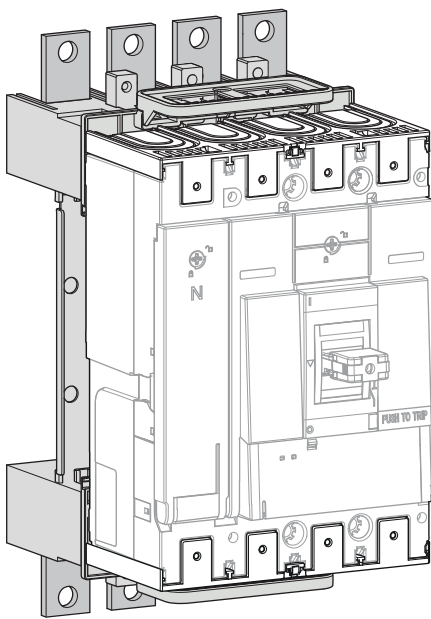

Plug-in P630 with front terminal P630

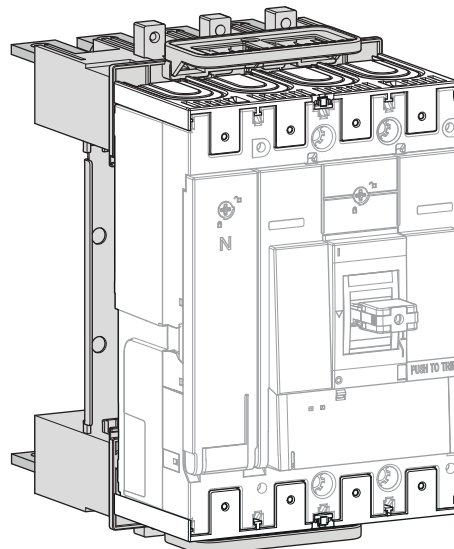

Plug-in with rear terminal P630

The plug-in system consists of an extraction mechanism directly mounted onto the circuit breaker and allows easy replacement of the device without removing the power conductors. The plug-in system ensures protection degree IP20 when the circuit breaker is removed.

The connection to the plug-in system of P160 and P250 can be done using cables fitted with lugs, front terminal extensions or rear terminals using the L connection that is separately available.

As for the P630 plug-in system, the connection is done using either front terminal extensions or rear terminals using the L connection.

The circuit breaker fitted with the plug-in system can be mounted in both vertical and horizontal positions.

The plug-in kit is composed of several accessories:

- Plug-in base
- Plug-in circuit breaker fitted with safety trip

Also available as an option:

- Auxiliary connectors
- Safety trip
- Front and rear connection terminals cables or bars

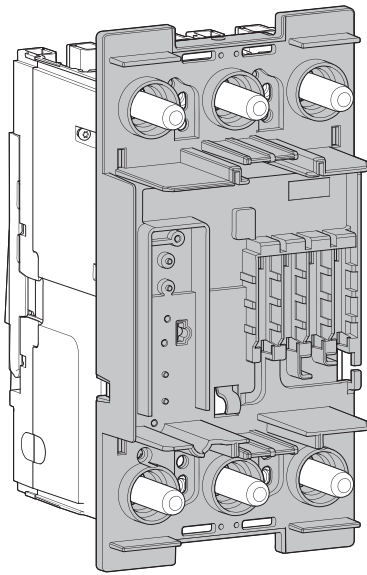

P250 Plug-in circuit breaker adaptor

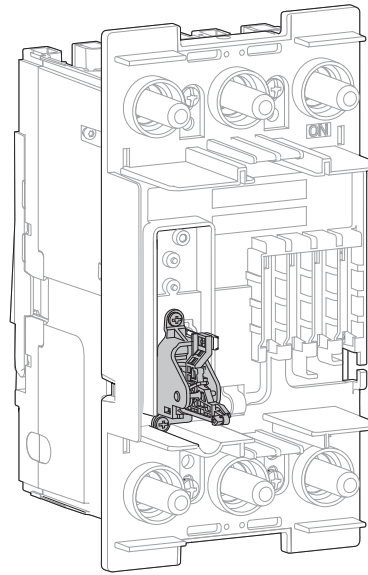

P250 Plug-in circuit breaker adaptor fitted with safety trip

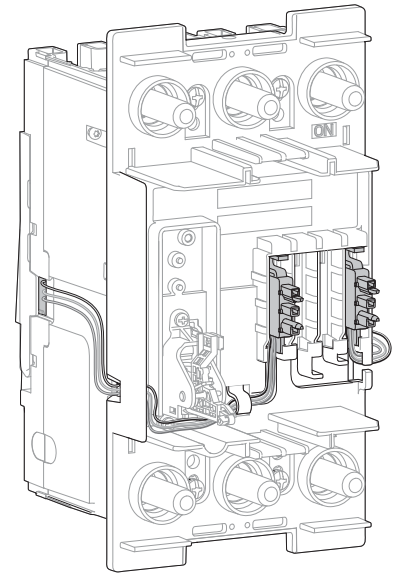

P250 Plug-in circuit breaker adaptor fitted with internal auxiliaries

Auxiliary contact:

Up to three auxiliary connectors can be mounted onto the plug-in of the P160. As for the P250 and P630, four connectors can be mounted on its plug-in accessory. The connectors are used to automatically connect or disconnect the internal AX/AL auxiliary contacts, the shunt trip or the undervoltage auxiliaries that are fitted inside the circuit breaker.

Safety trip:

For P160, P250 and P630 plug-in systems, a safety trip accessory is supplied and can be mounted on the plug-in base to trip the circuit breaker when removed without having been set to the OFF position.

Plug-in system: Front or rear connection terminals

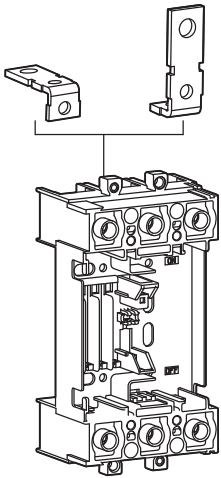

Plug-in base

Separate front or rear connection terminals can be mounted onto the base depending on the connection arrangement needed.

The plug-in base can be mounted on a back plate, a back U-plate or a flush mounting plate. It is delivered with two isolating shields if mounting is on a plain metallic back plate.

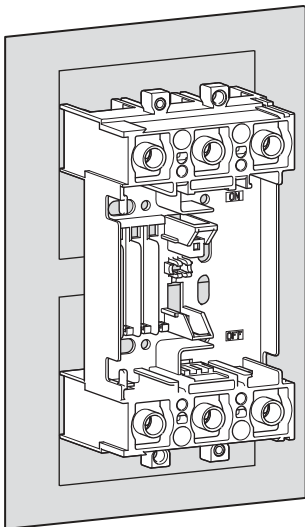

Plug-in on back plate

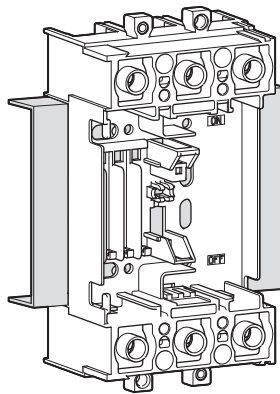

Plug-in on U-plate

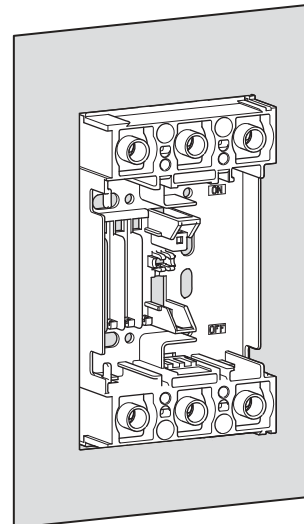

Plug-in flushmounted

Withdrawable system

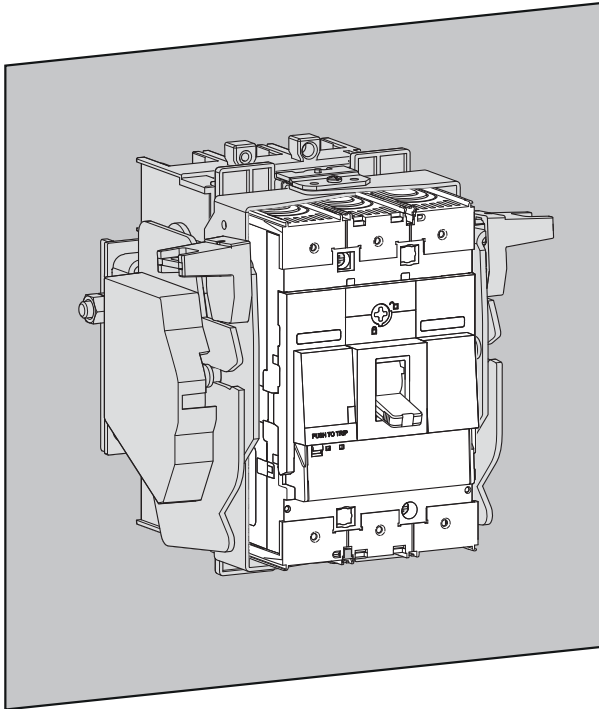

P250 withdrawable

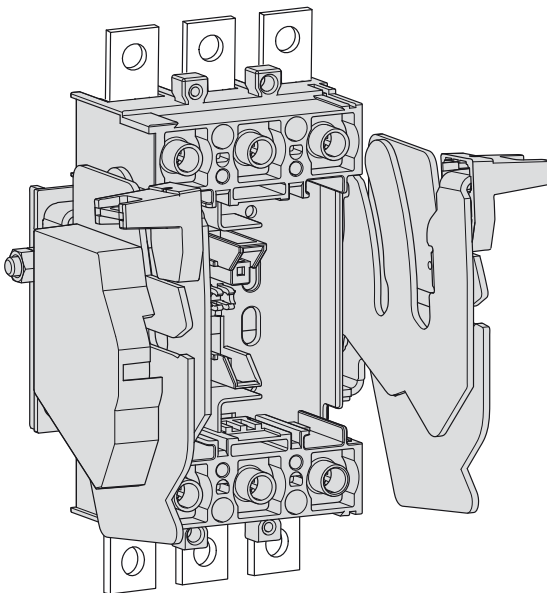

Withdrawable base P250

Based on the P250 plug-in system, the withdrawable system allows easy handling of the circuit breaker. It permits its disconnection without having to remove it completely from the installation.

The withdrawable system is compatible with circuit breakers mounted in a vertical position only.

The withdrawable system has 3 positions:

- Connected: the power circuit is connected.
- Disconnected: the power circuit is disconnected; the MCCB is isolated and can be operated to check auxiliary operation.
- Removed: the MCCB is detached and can be removed from the installation.

The withdrawable kit is composed of the following parts:

- Chassis,
- Plug-in circuit breaker adaptor fitted with driving case.

Also available as an option:

- Auxiliary connectors
- Safety trip
- Position switch
- Front connection terminals

The withdrawable adaptor must be mounted to the back of the MCCB.

Up to 5 auxiliary connectors can be mounted onto the plug-in to automatically connect and disconnect the internal AX/AL, shunt trip or undervoltage auxiliaries fitted into the MCCB.

As an option, a safety trip accessory can be mounted onto the withdrawable system. This option trips the MCCB when it is removed from the base without it having been set to the OFF position.

As an option, a position switch can be mounted on the withdrawable adaptor to indicate through an auxiliary circuit the connected or disconnected position of the MCCB into the withdrawable base. The withdrawable base is not supplied with terminal connections. Separate front or rear bar terminals can be mounted onto the base depending on the connection arrangement needed.

It is delivered with two isolating shields in case it needs to be mounted on a metallic back plate.

Withdrawable system

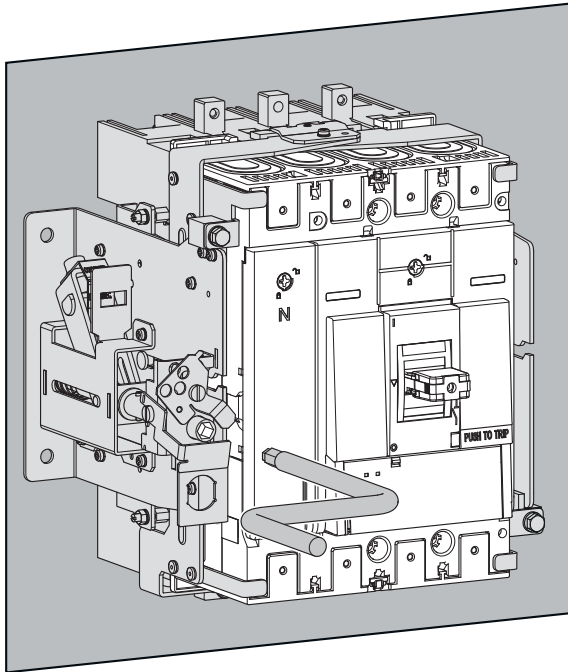

P630 withdrawable

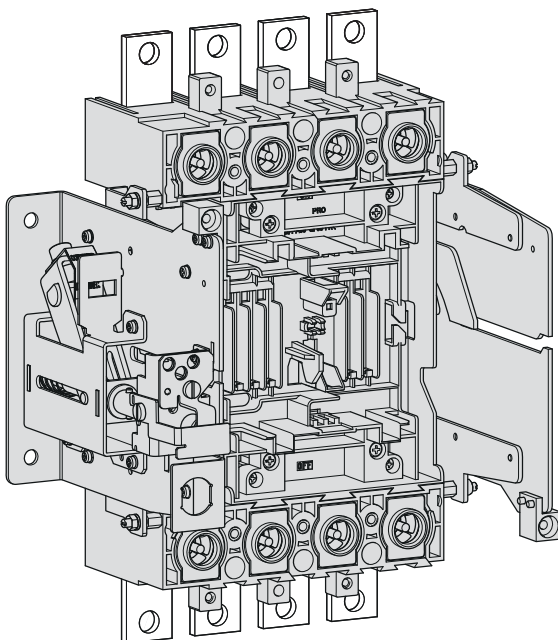

Withdrawable base P630

Based on the P630 plug-in system, the withdrawable system allows easy handling of the circuit breaker. It permits its disconnection without having to remove it completely from the installation.

The withdrawable system is compatible with circuit breakers mounted in a vertical position only.

The withdrawable system has 3 positions:

- Connected: the power circuit is connected.
- Disconnected: the power circuit is disconnected; the MCCB is isolated and can be operated to check auxiliary operation.
- Removed: the MCCB is detached and can be removed from the installation.

The withdrawable kit is composed of the following parts:

- Chassis,
- Plug-in circuit breaker adaptor fitted with driving case.

Also available as an option:

- Auxiliary connectors
- Safety trip
- Position switch
- Front connection terminals

The withdrawable adaptor must be mounted to the back of the MCCB.

Up to 5 auxiliary connectors can be mounted onto the plug-in to automatically connect and disconnect the internal AX/AL, shunt trip or undervoltage auxiliaries fitted into the MCCB.

As an option, a safety trip accessory can be mounted onto the withdrawable system. This option trips the MCCB when it is removed from the base without it having been set to the OFF position.

As an option, a position switch can be mounted on the withdrawable adaptor to indicate through an auxiliary circuit the connected or disconnected position of the MCCB into the withdrawable base. The withdrawable base is not supplied with terminal connections. Separate front or rear bar terminals can be mounted onto the base depending on the connection arrangement needed.

It is delivered with two isolating shields in case it needs to be mounted on a metallic back plate.

Direct rotary handles

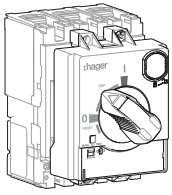

Rotary handle P160

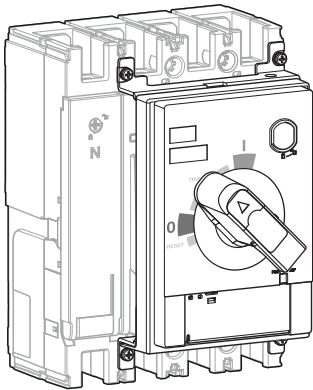

Rotary handle P630

Direct rotary handle features:

- Suitable for insulation,
- Clear indication of the 3 positions: ON, OFF and TRIP,
- Circuit breaker built-in “PUSH TO TRIP” test button accessible on the direct rotary handle,
- Trip unit dial settings accessible through the direct rotary handle,
- Integrated padlocking facility. Keylock as an option.
- ¼ turn screws to ease the mounting in front of P160-P250 MCCBs and facilitate the access to the internal auxiliary contacts.

The circuit breaker can be locked in ON or OFF positions with one to three padlocks (not supplied). Padlock shackle: Ø 5.5 - 8 mm.

Locking in ON position does not prevent the circuit breaker from tripping when there is a fault. In this case, when the circuit breaker trips the handle is on TRIP position. To reset, it is necessary to unlock the direct rotary handle.

A different direct rotary handle providing the door interlocking function is available to prevent the door opening when the circuit breaker is in the ON position.

A Ronis type keylock is available as an option to mount on the direct rotary handle base. The keylock ensures the circuit breaker locks in both OFF or ON positions or only in OFF position.

On door rotary handles

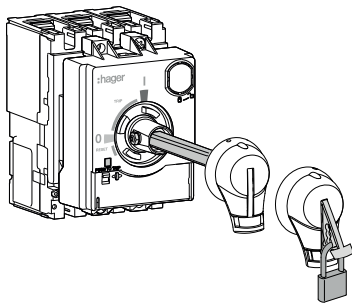

P160 on door rotary handle

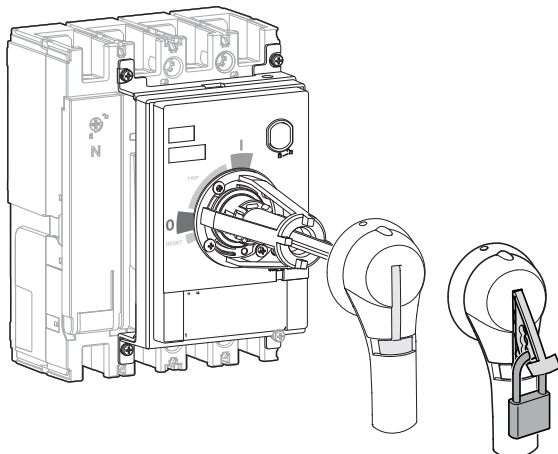

P630 on door rotary handle

On door rotary handle features:

- Suitable for insulation,
- Clear indication of the 3 positions: ON, OFF and TRIP,
- Circuit breaker built-in “PUSH TO TRIP” test button accessible on the base fitted directly onto the circuit breaker,
- Trip unit dial settings accessible through the base,
- Integrated padlocking facility. Keylock as an option to mount on the base.
- ¼ turn screws to ease the mounting in front of P160-P250 MCCBs and facilitate the access to the internal auxiliary contacts.

The circuit breaker can be locked in OFF position with one to three padlocks (not supplied). Padlock shackle: Ø 5.5 - 8 mm.

It is necessary to unlock the extended rotary handle in order to reset the circuit breaker after tripping.

A Ronis type keylock is available as an option to mount on the base fitted directly onto the circuit breaker. The keylock ensures the circuit breaker locks in both OFF or ON positions.

Motor operator with auto-reset mode

An auto-reset motor operator version allows automatic resetting of the circuit breaker after tripping.

Remote command

The remote command circuit is based on an ON and OFF signal with a screwless terminal that is compatible with cables up to 2 mm².

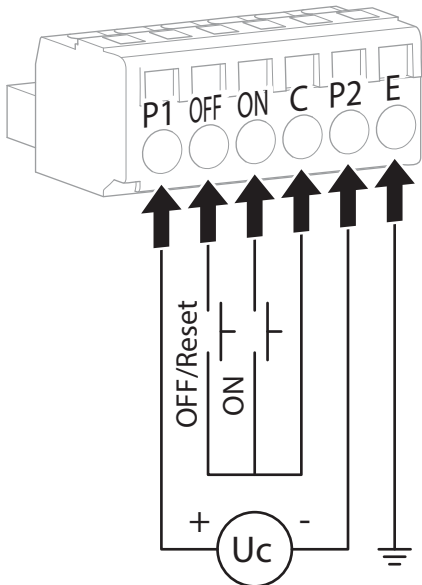

Terminal Motor operator

For P250 motors

Rated operating voltage	Un	24 V DC	48 V DC	100-110 V DC	200-220 V DC	100-110 V AC	200-220 V AC	230-240 V AC
Frequency	Hz	-	-	-	-	50/60	50/60	50/60
Operating current / Starting current Peak value	A	14.1/26.5	11.4/17.1	3.4/7.6	4.2/5.9	3.6/8.7	3.6/6.6	3.4/6
Operating method		Direct drive						
Operating time	ON	ms	<100					
	OFF	ms	<100					
	RESET	ms	<100					
Operating frequency	Cycle / min.	4						
Power supply required	VA	>300						

For P630 motors

Rated operating voltage	Un	24-48 V DC	100-120 V DC	100-240 V AC
Frequency	Hz	-	-	50 / 60
Operating current / Starting current Peak value	ON	A	-	-
	OFF, RESET	A	6.7	1.0
Operating method		Direct drive		
Operating time	ON	s	0.1	
	OFF	s	1.4	
	RESET	s	1.5	
Operating frequency	Cycle / min.	4		
Power supply required	VA	300 min.		

ON and OFF command is available with the following power supply:

- 24 V DC
- 48 V DC
- 100-120 V AC/DC
- 200-220 V AC/DC
- 230-240 V AC

Plug-in and withdrawable mounting accessories are compatible with the P250 circuit breaker fitted with an electrical motor operator.

- Accessories available as an option:
- Keylock for locking in the OFF position,
- Electrical interlocking.

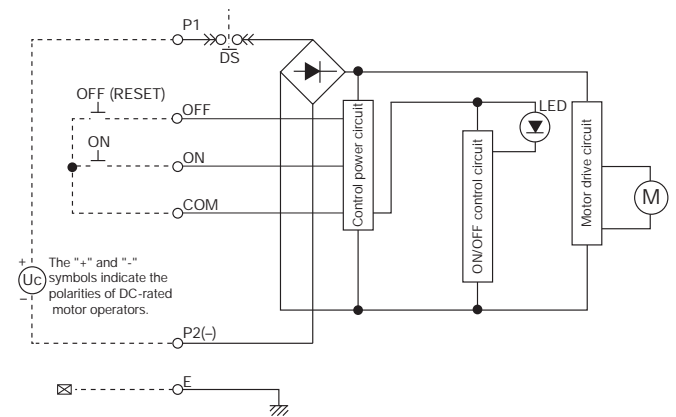

Locking system

Padlocking systems can be fitted with up to three shackle padlocks with diameters of 5 to 8 mm. Locking in the OFF position ensures isolation and compliance to the IEC 60947-2 standard.

Device	Function	Means	Specific accessory
Standalone MCCB	Lock in OFF or ON position	Padlock	-
		Cable tie	-
		Up to 3 padlocks	Palocking kit
Direct rotary handle	Lock in OFF or ON position	Up to 3 padlocks	-
	Lock in OFF or ON position	Keylock	Locking device + keylock
Extended rotary handle	Lock in OFF position	Up to 3 padlocks	-
	Lock in ON or OFF position	Keylock	Locking device + keylock
Motor operator	Lock in OFF position	Up to 3 padlocks	-
		Keylock	Locking device + keylock
Drawout	Lock in DISCONNECT or CONNECT position	Up to 3 padlocks	-
		Keylock	Locking device + keylock
	Lock only in CONNECT position	Keylock	Locking device + keylock

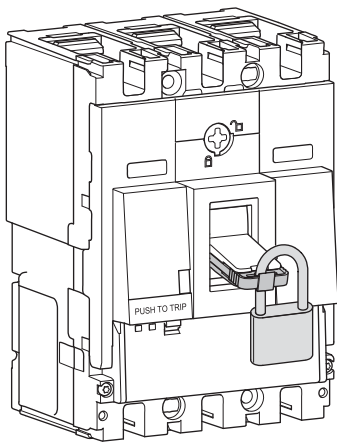

Direct with 4 mm shackle padlock

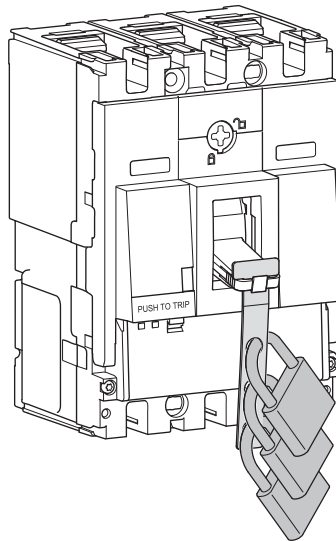

Padlocking kit with three pieces of up to 6 mm shackle padlocks

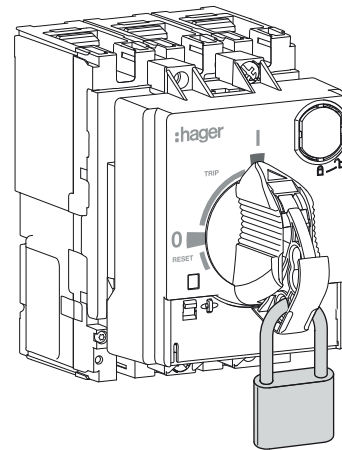

Padlock direct rotary handle

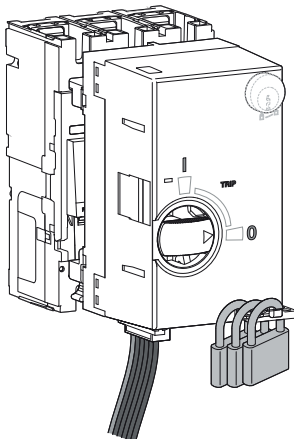

Padlock motor operator

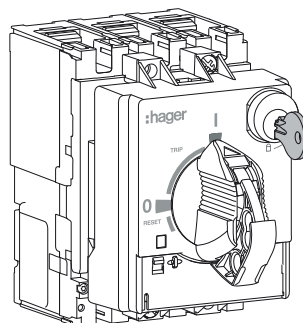

Key lock direct rotary handle

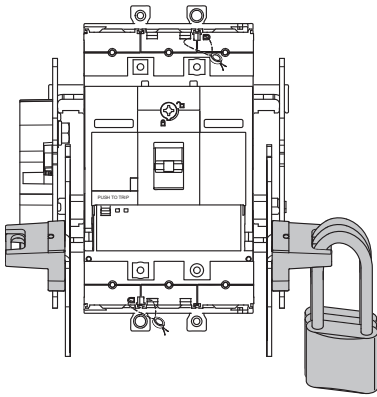

Key lock motor operator P250

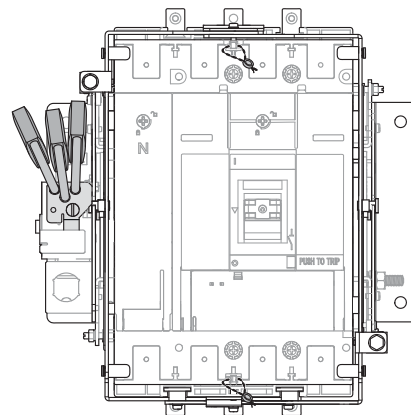

Key lock withdrawable P630

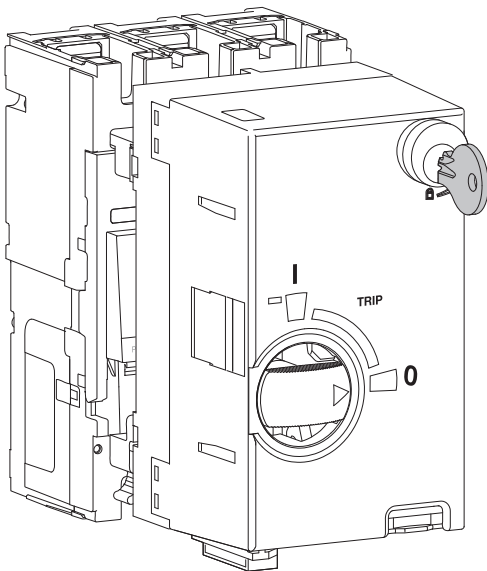

Key lock motor operator P250

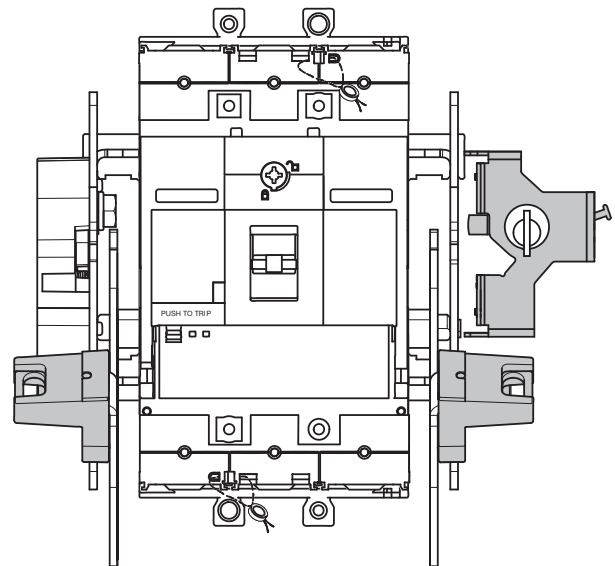

Key lock withdrawable P250

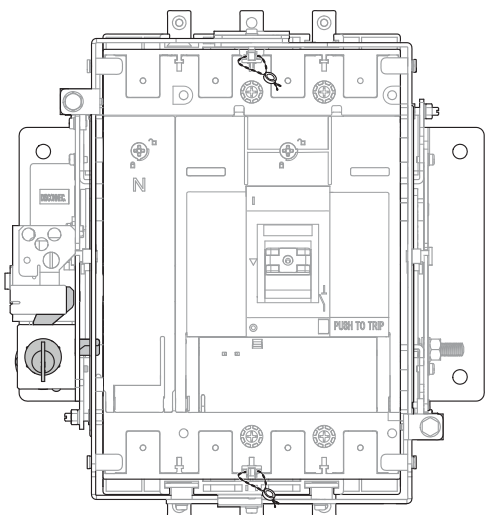

Key lock withdrawable P630

Sealing

A sealing accessory is available on request. Each sealing kit contains all parts necessary to seal the circuit breakers as indicated below.

Circuit breaker

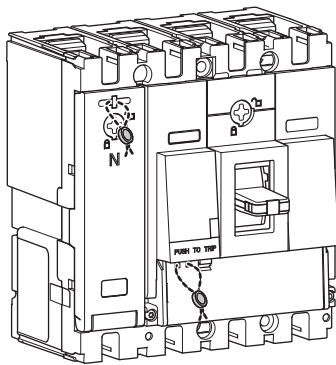

Seals on front covers

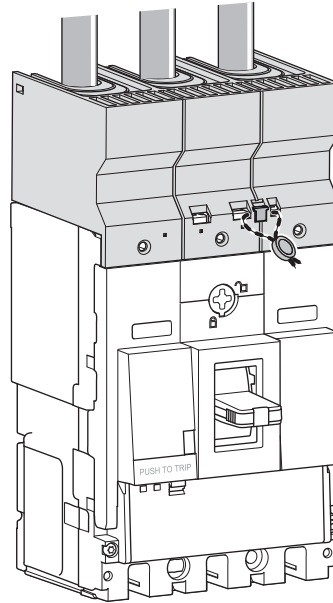

Seal on terminal cover P160

Direct rotary handle

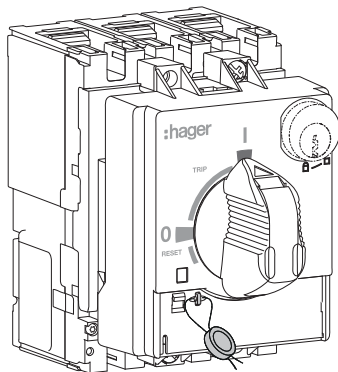

Seal on front cover rotary handle P160

RCD add-on block

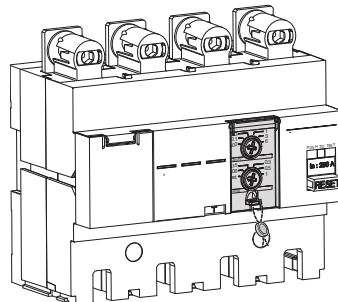

Seal on RCD add-on block

Link interlock

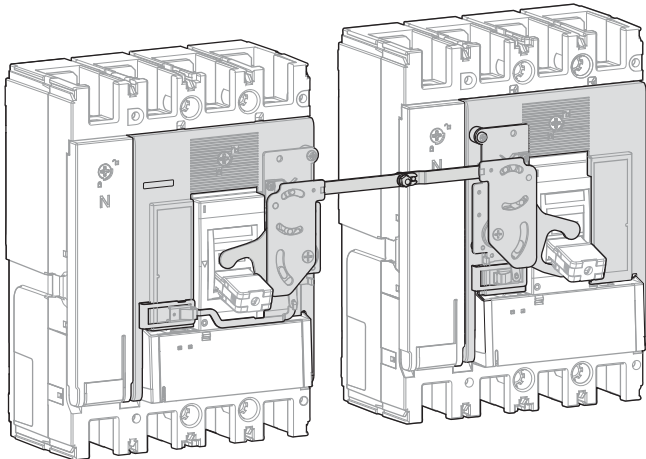

This solution is a connecting rod to make a link between two h3+ MCCBs of the same frame size mounted side by side.

This accessory interlocks mechanically two circuit breakers in order to prevent from the following operations:

- Switch ON a circuit breaker when the other one is already in ON position
- Switch ON a circuit breaker when the other one is in TRIP position.

The link interlock accessory is a set of two link interlock front covers that shall be mounted on the front side of the interlocked circuit breakers

Cable interlock

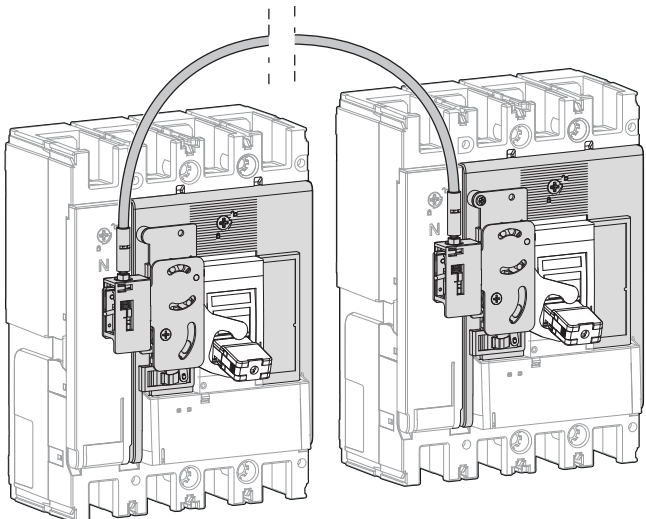

This solution allows two h3+ MCCBs of the same or different frame sizes to be interlocked.

Both circuit breakers don't necessary need to be of the same size nor mounted side by side thanks to the interlocking cable.

This accessory interlocks mechanically two circuit breakers in order to prevent from the following operations:

- Switch ON a circuit breaker when the other one is already in ON position
- Switch ON a circuit breaker when the other one is in TRIP position.

Three accessory references are needed to realise the cable interlock solution

- The mechanical interlocking front cover for each MCCB. It is mounted on the circuit breaker.
- The cable available in 1 m or 1.5 m.

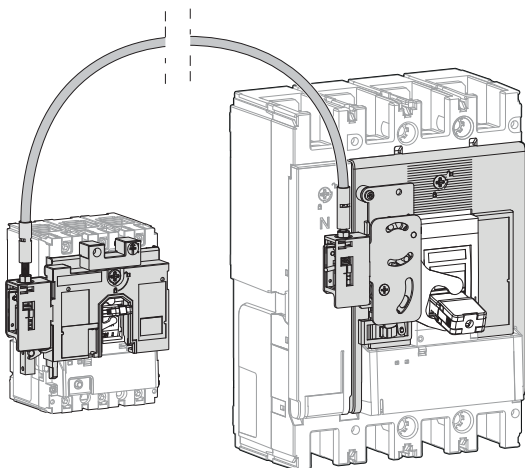

Interlocking combined with rotary handles

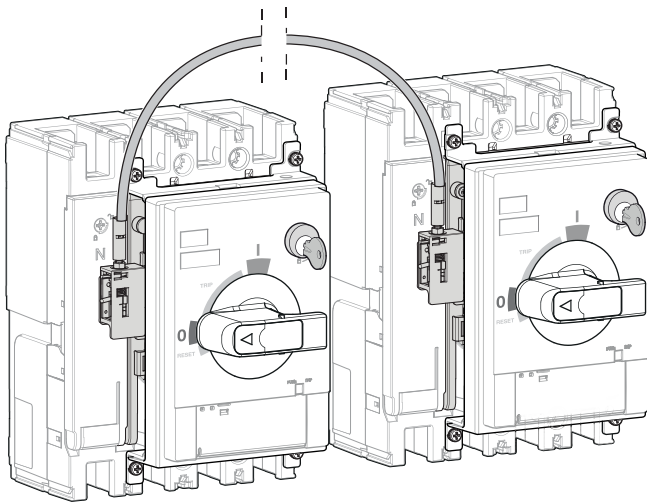

Cable interlocking solution is compatible with direct and on-door rotary handles.

Operating the MCCBs is done using the rotary handle mechanism.

Interlocking solutions are compatible with direct and on-door rotary handles.

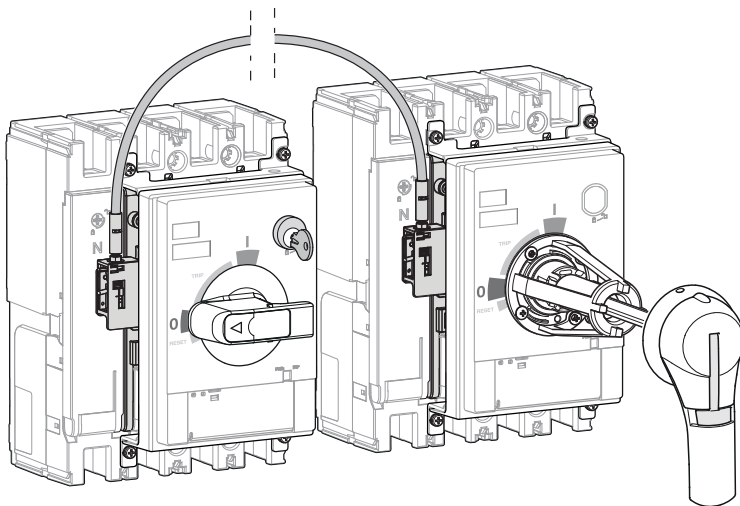

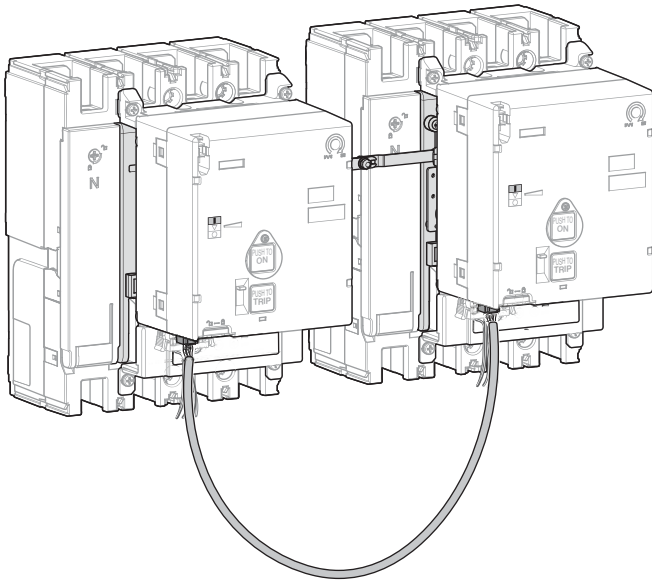
Link interlocking combined with motor operators

This solution is a solid connecting rod to make a link between two h3+ MCCBs of the same frame size mounted side by side. In this case, in addition to the mechanical interlocking, it is mandatory to use the electrical interlock accessory in order to secure the complete interlocking system.

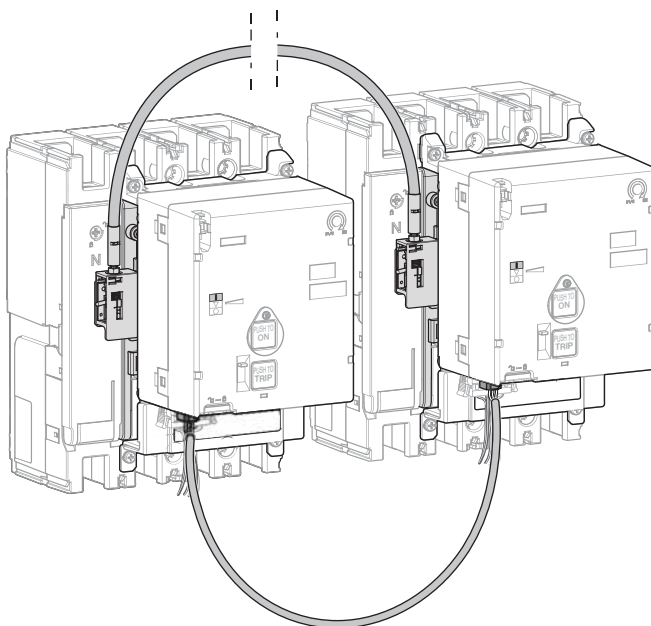
Cable interlocking combined with motor operators

This solution allows the interlocking of two h3+ MCCBs using a cable. The MCCBs can be of different frame sizes and not necessarily located next to each other. Two cable lengths are proposed to increase the flexibility of the installation.

In this case, in addition to the mechanical interlocking, it is mandatory to use the electrical interlock accessory in order to secure the complete interlocking system.

Installation and operating recommendations

Page

01 Installation and operating conditions 2	102
02 Safety clearances and minimum distances	106
03 Power loss	108

Altitude derating

Up to an altitude of 2000 m above sea level, there is no derating to apply on electrical properties of the h3+ P160 P250 and P630. Above 2000 m a reduction of the air density decreases the heat dissipation of the circuit breaker and downgrades the dielectric strength. A derating on electrical characteristics must be applied as indicated below to compensate this phenomenon.

The following table gives the corrections to apply for altitudes above 2000 m. The breaking capacities I_{cu} and I_{cs} remain unchanged.

Altitude (m)	2000	3000	4000	5000
Dielectric withstand voltage (V)	2500	2160	1900	1670
U _i Insulation voltage (V)	800	690	610	535
Maximum operating voltage (V)	690	600	525	460
I _{th} Maximum thermal current (A) at 50 °C	1	0.96	0.93	0.9

International protection marking

h3+ circuit breakers comply with the following international protection markings as defined by IEC 60529 and IEC 60947-1 standards, Appendix C. Connection parts without terminal covers may be IP20 or less depending on the isolation protection applied on the cables.

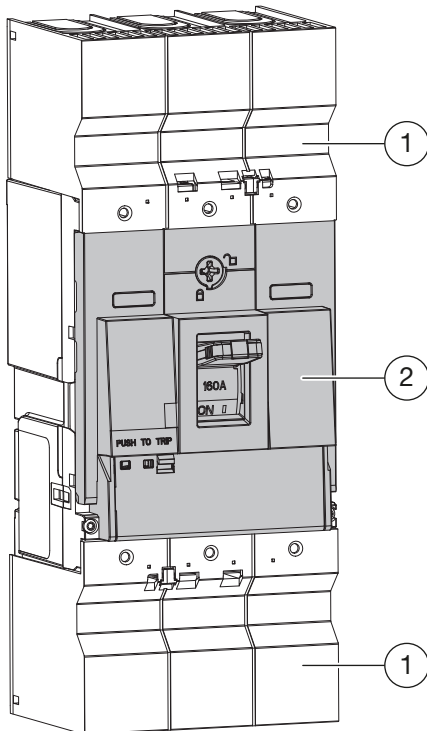

IP of the different areas

- 1 IP20: side, back, terminal cover
- 2 IP40: front cover

Vibrations

h3+ P160, P250 and P630 circuit breaker withstand mechanical vibrations.

h3+ complies to IEC 60068-2-52:

- 2.0 to 13.2 Hz and amplitude ±1 mm
 - 13.2 to 100 Hz acceleration ±0.7 g
 - Resonance frequency (±1 mm/±0.7 G) during 90 min
- Excessive vibration may cause false tripping and/or damage to connections and/or mechanical parts.

Electromagnetic disturbances

h3+ circuit breakers are protected against:

- overvoltage caused by circuit switching,
- overvoltage caused by atmospheric disturbances or a distribution-system outage (e.g. failure of a lighting system),
- devices emitting radio waves (radios, walkie-talkies, radar, etc.),
- electrostatic discharges produced directly by users.

P160, P250 and P630 circuit breakers have successfully passed the electromagnetic-compatibility tests (EMC) with immunity levels listed in the General Characteristics chapter.

Degree of protection IP40 is achieved when an h3+ circuit breaker is installed in a switchboard with a front panel cut-out covering a minimum the protection settings window. Higher protection degree of IP65 can be achieved by installing a door mounted external rotary handle.

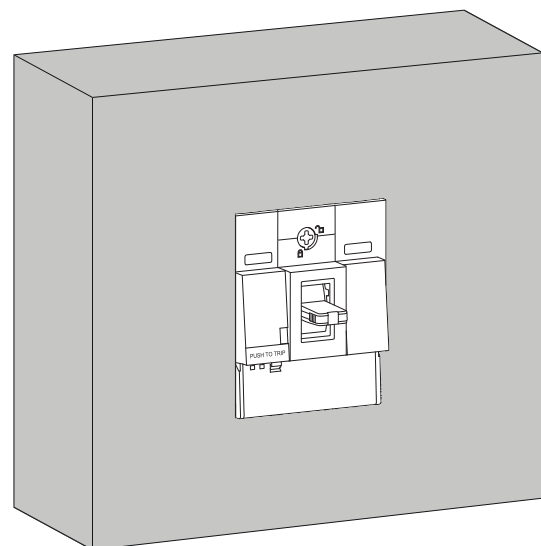

Front panel IP40

Mounting position

h3+ P160, P250 and P630 circuit breakers can be mounted at any angle without affecting the performance and the characteristics.

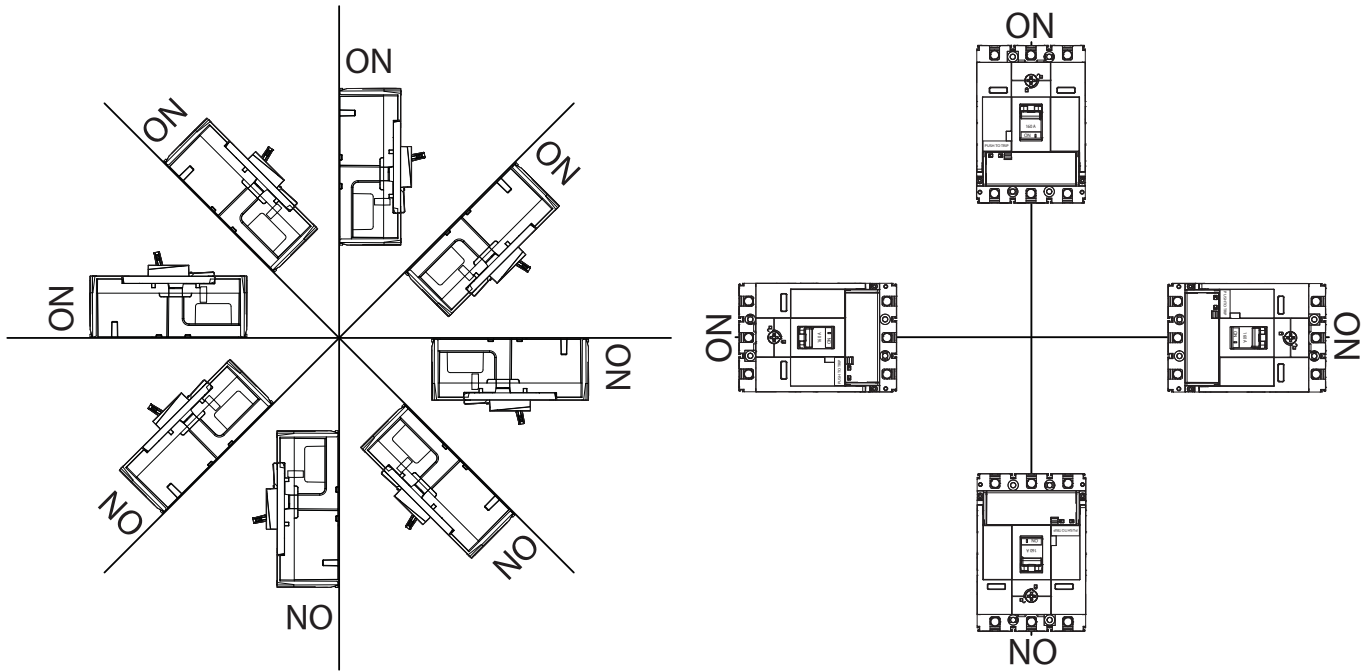

Direction of power supply

h3+ circuit breakers can be supplied from either the top or the bottom, without any decrease in performance. All connections and insulation accessories can be used on circuit breakers supplied either from the top or from the bottom.

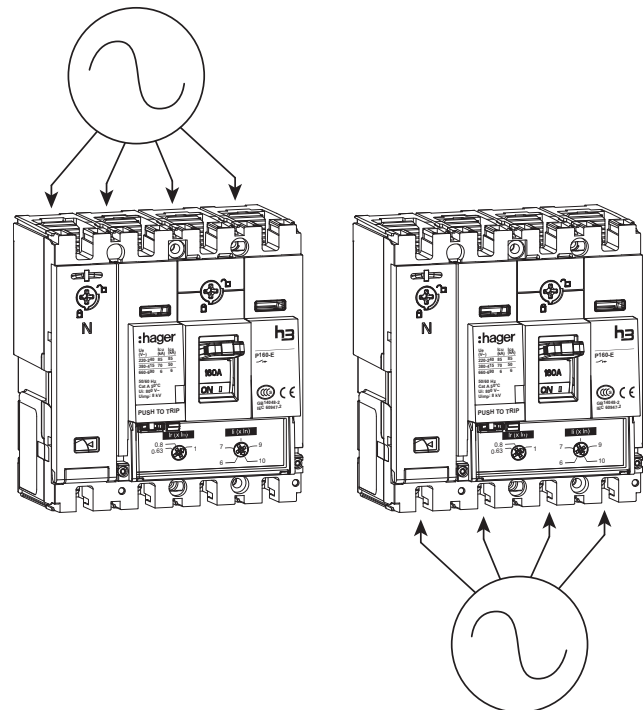

Installation and operating recommendations

Derating due to temperature

h3+ P160 and P250 thermo-magnetic circuit breakers are calibrated at 50 °C ambient temperature for the overload protection. This means that when the ambient temperature is less or greater than 50 °C, the Ir protection pick-up threshold is slightly modified.

h3+ P160 and P250 circuit breakers have to be derated as indicated in the table below:

Ambient temperature influences on Ir settings of the P160 TM circuit breaker

In (A)	Ir ... x In	Temperature °C												
		10	15	20	25	30	35	40	45	50	55	60	65	70
25	0.63	19.3	18.9	18.5	18.1	17.7	17.3	16.9	16.4	16	15.5	15.1	14.6	14.1
	0.8	24.1	23.6	23.2	22.7	22.2	21.6	21.1	20.6	20	19.4	18.8	18.2	17.6
	1	30.1	29.6	28.9	28.3	27.7	27.0	26.4	25.7	25	24.3	23.5	22.8	22.0
40	0.63	31.2	30.5	29.8	29.0	28.3	27.5	26.7	25.9	25	24.1	23.2	22.2	21.2
	0.8	39.9	39.0	38.1	37.2	36.2	35.2	34.2	33.1	32	30.9	29.7	28.5	27.2
	1	49.9	48.8	47.6	46.5	45.2	44.0	42.7	41.4	40	38.6	37.1	35.6	34.0
63	0.63	55.3	53.6	51.9	50.1	48.3	46.3	44.3	42.2	40	37.7	35.1	32.5	29.5
	0.8	69.1	67.0	64.9	62.6	60.3	57.9	55.4	52.8	50	47.1	43.9	40.6	36.9
	1	87.1	84.5	81.7	78.9	76.0	73.0	69.8	66.5	63	59.3	55.4	51.1	46.5
80	0.63	64.0	62.4	60.8	59.1	57.4	55.6	53.8	51.9	50	48.0	45.9	43.6	41.3
	0.8	80.6	78.6	76.6	74.5	72.3	70.1	67.8	65.5	63	60.4	57.8	55.0	52.0
	1	102.3	99.8	97.2	94.6	91.8	89.0	86.1	83.1	80	76.8	73.4	69.8	66.1
100	0.63	78.3	76.5	74.8	72.9	71.1	69.1	67.1	65.1	63	60.8	58.6	56.2	53.8
	0.8	99.4	97.2	94.9	92.6	90.2	87.8	85.3	82.7	80	77.2	74.4	71.4	68.3
	1	124.3	121.5	118.7	115.8	112.8	109.7	106.6	103.3	100	96.5	93.0	89.2	85.3
125	0.63	94.0	92.4	90.7	89.0	87.3	85.5	83.7	81.9	80	78.1	76.1	74.1	72.0
	0.8	117.5	115.5	113.4	111.3	109.1	106.9	104.7	102.4	100	97.6	95.1	92.6	90.0
	1	146.9	144.3	141.7	139.1	136.4	133.6	130.8	127.9	125	122.0	118.9	115.7	112.5
160	0.63	120.1	117.7	115.4	113.0	110.5	108.0	105.4	102.7	100	97.2	94.3	91.3	88.3
	0.8	150.1	147.2	144.2	141.2	138.1	135.0	131.7	128.4	125	121.5	117.9	114.2	110.3
	1	192.1	188.4	184.6	180.7	176.8	172.7	168.6	164.4	160	155.5	150.9	146.2	141.2

Ambient temperature influences on Ir settings of the P250 TM circuit breaker

In (A)	Ir ... x In	Temperature °C												
		10	15	20	25	30	35	40	45	50	55	60	65	70
50	0.63	40.4	39.4	38.4	37.4	36.4	35.4	34.3	33.2	32	30.8	29.5	28.2	26.9
	0.8	50.4	49.3	48.0	46.8	45.5	44.2	42.8	41.4	40	38.5	36.9	35.3	33.6
	1	63.1	61.6	60.1	58.5	56.9	55.3	53.6	51.8	50	48.1	46.2	44.1	42.0
63	0.63	52.8	51.3	49.9	48.4	46.8	45.2	43.5	41.8	40	38.1	36.1	34.0	31.7
	0.8	66.0	64.2	62.4	60.5	58.5	56.5	54.4	52.3	50	47.6	45.1	42.5	39.7
	1	83.1	80.9	78.6	76.2	73.7	71.2	68.6	65.9	63	60.0	56.9	53.5	50.0
100	0.63	81.7	79.6	77.4	75.2	72.9	70.6	68.1	65.6	63	60.3	57.4	54.4	51.2
	0.8	103.7	101.0	98.3	95.5	92.6	89.6	86.5	83.3	80	76.5	72.9	69.1	65.0
	1	129.6	126.3	122.9	119.4	115.8	112.0	108.2	104.2	100	95.7	91.1	86.3	81.2
125	0.63	97.1	95.1	93.1	91.0	88.9	86.8	84.6	82.3	80	77.6	75.1	72.6	69.9
	0.8	121.3	118.9	116.4	113.8	111.2	108.5	105.7	102.9	100	97.0	93.9	90.7	87.4
	1	151.7	148.6	145.5	142.3	139.0	135.6	132.2	128.6	125	121.3	117.4	113.4	109.3
160	0.63	124.7	121.9	119.0	116.1	113.1	109.9	106.7	103.4	100	96.5	92.8	89.0	85.0
	0.8	155.9	152.4	148.8	145.1	141.3	137.4	133.4	129.3	125	120.6	116.0	111.2	106.2
	1	199.6	195.1	190.5	185.7	180.9	175.9	170.8	165.5	160	154.3	148.5	142.3	135.9
200	0.63	164.9	160.5	155.9	151.2	146.3	141.3	136.1	130.7	125	119.1	112.8	106.2	99.2
	0.8	211.1	205.4	199.5	193.5	187.3	180.9	174.2	167.2	160	152.4	144.4	136.0	127.0
	1	263.8	256.7	249.4	241.9	234.1	226.1	217.7	209.0	200	190.5	180.5	170.0	158.7
250	0.63	198.5	194.1	189.6	185.0	180.3	175.4	170.4	165.3	160	154.5	148.8	142.9	136.7
	0.8	248.1	242.6	237.0	231.3	225.4	219.3	213.1	206.6	200	193.1	186.0	178.6	170.9
	1	310.2	303.3	296.3	289.1	281.7	274.1	266.3	258.3	250	241.4	232.5	223.3	213.7

Ambient temperature influences on nominal ratings (In) of the electronic circuit breakers

The temperature of the electronic circuit breaker depends on the current flow and the ambient temperature.

Above 50 °C ambient temperature a derating on the nominal rating must be applied to not exceed the maximum thermal withstand of the circuit breaker.

However the ambient temperature does not affect the protection setting of electronic circuit breakers.

	In (A)	Temperature °C			
		50	60	65	70
P160	40	40	40	40	40
	100	100	100	100	100
	160	160	159	145	135
P250	40	40	40	40	40
	100	100	100	100	100
	160	160	160	145	135
	250	250	240	220	200
P630	250	250	250	250	250
	400	400	400	400	400
	630	630	622	570	510

Derating of Plug in and AOB

For circuit breakers equipped with RCD Add-on block, plug In or drawout systems, an additional derating coefficient has to be applied.

Rating	Coefficient
< 630A	1
630A	0.97

Insulation distances

The insulation distances between the MCCB and its surroundings (earthed metal parts – insulators, etc.) must be maintained to prevent arcing faults which may occur due to conductive ionised gas.

In some cases where other specifications require different insulation distances to those shown here, the greater distance must be maintained. In case of two different models are installed above each other, the insulation distance between the two models should be according to the model specifications of the circuit breaker on the downside.

h3+ MCCBs can be mounted side by side without minimum insulation distance.

NOTE

Exposed conductors must be insulated up to the circuit breaker terminals. We recommend using interphase barriers or connection covers.

If the optional connector covers are used, isolate the exposed conductor until it overlaps the connector cover.

Minimum distance between h3+ MCCB and top, bottom or side panel

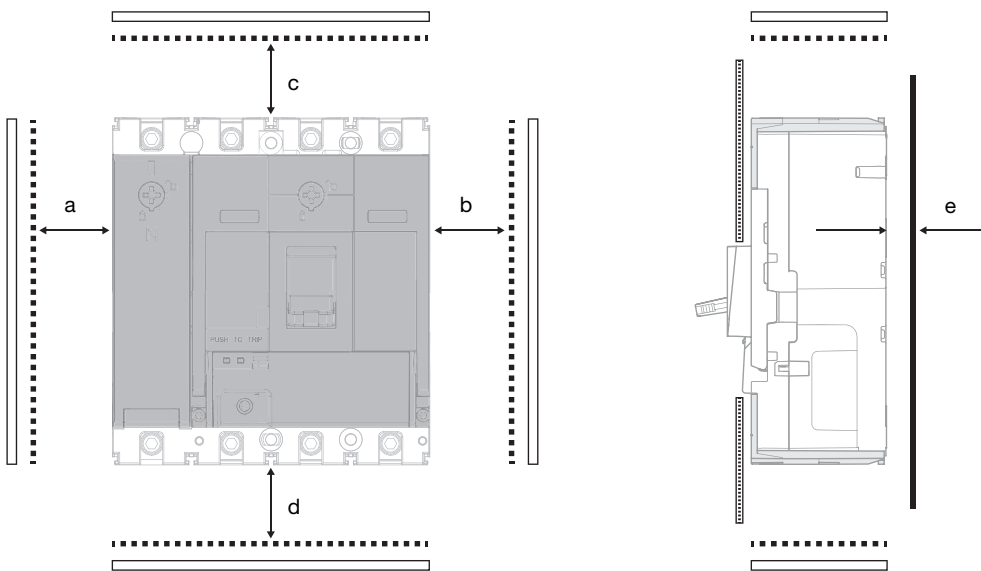

Non-metallic plate
 Metal mounting plate
 Earthed metallic part

	Earthed metallic plate				Non-metallic plate		
	P160	P250	P630		P160	P250	P630
Ue ≤ 690 V							
Breaking capacity	Icu ≤ 70kA	Icu ≤ 70kA	Icu ≤ 70kA	Icu ≤ 110kA			
a (mm)	≥ 50	≥ 50	≥ 80	≥ 80	0	0	0
b (mm)	≥ 50	≥ 50	≥ 80	≥ 80	0	0	0
c (mm)	≥ 50	≥ 50	≥ 80	≥ 120	≥ 75	≥ 100	≥ 100
d (mm)	≥ 50	≥ 50	≥ 80	≥ 120	≥ 75	≥ 100	≥ 100
e (mm)	0	0	0	0	0	0	0

Minimum distance h3 breaker connections

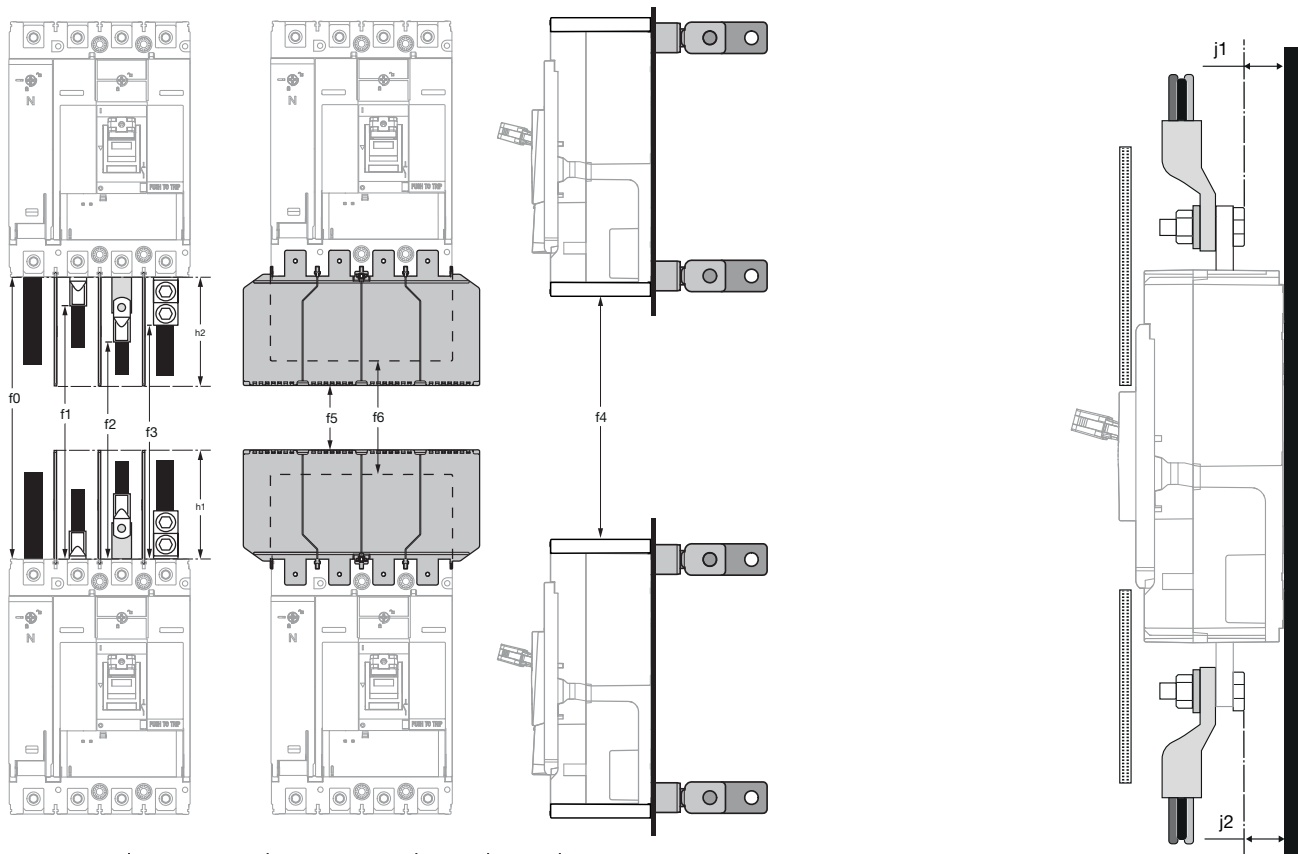

Dimension (mm)	Type of connection	Type of protection	P630			
			P160	P250	≤ 415V	690V
f0	Isolated bar	Interpole barrier	≥ 100	≥ 200	≥ 350	-
f1	Ring Lug	Interpole barrier	≥ 100	≥ 200	≥ 350	-
f2	Extender	Interpole barrier	≥ 100	≥ 200	≥ 350	-
f3	External alu collar	Interpole barrier	≥ 100	≥ 200	≥ 350	-
f4	Rear connection	Terminal cover zero	≥ 75	≥ 150	≥ 220	≥ 260
f5	Spreader	Terminal cover spreader	≥ 50	≥ 50	≥ 50	≥ 50
f6	Ring Lug	Terminal cover straight	≥ 50	≥ 50	≥ 110	≥ 110
f6	Extender	Terminal cover straight	≥ 50	≥ 50	≥ 110	≥ 110
f6	External alu collar	Terminal cover straight	≥ 50	≥ 50	≥ 110	≥ 110
h1	Ring Lug + Interpole barrier	Normal Feeding	≥ 50	≥ 100	0	≥ 110
		Reverse Feeding	≥ 50	≥ 100	0	≥ 110
h2	Ring Lug + Interpole barrier	Normal Feeding	0	0	0	≥ 110
		Reverse Feeding	≥ 50	≥ 100	0	≥ 110

Dimension (mm)		P160	P250	P630
j1 (mm) upstream / j2 (mm) downstream	Normal Feeding / Reverse Feeding	≥ 8	≥ 8	≥ 25

In case j1 or j2 is lower than the indicated values, an insulation earth plate is mandatory.

Power loss

Thermal power loss values of h3+ Circuit breakers are used to calculate total temperature rise in the switchboard in which they are installed.

The values indicated in the tables below are typical values for a device operating at a full rated load with a frequency of 50/60 Hz.

The value of the resistance per pole is provided as a general indication for a new device. It is determined on the basis of the measured voltage drop.

The value indicated is the power loss per pole at I_n , 50/60 Hz. Measurement and calculation of power loss are carried out in compliance with the recommendations of Appendix G of standard IEC 60947-2.

Total power loss at full rated load and 50/60 Hz is equal to power losses per pole multiplied by 3.

Power loss TM circuit breakers

	Rating I_n (A)	Z per pole (m Ω)	P / pole (W)	P / product 3P or 4P (W)
P160	25	10.4	6.5	19.5
	32	8.8	9	27
	40	5.8	9.3	27.9
	63	0.88	3.5	10.5
	80	0.92	5.9	17.7
	100	0.67	6.7	20.1
	125	0.68	10.7	32.1
	160	0.55	14.1	42.3
P250	50	2.00	5	15
	63	1.17	4.65	13.95
	100	0.60	6	18
	125	0.60	9.3	27.9
	160	0.38	9.7	29.1
	200	0.30	12	36
	250	0.27	16.9	50.7

Power loss electronic circuit breakers

	Rating I_n (A)	Z per pole (m Ω)	P / pole (W)	P / product 3P or 4P (W)
P160	40	0.35	0.56	1.68
	100	0.35	3.5	10.5
	160	0.35	9	27
P250	40	0.24	0.38	1.2
	100	0.24	2.4	7.2
	160	0.24	6.14	18.4
	250	0.24	15	45
P630	250	0.196	12.3	36.8
	400	0.19	30	90
	630	0.15	58.6	175.8

Additional power loss

Power loss caused by the mounting accessories has to be taken into account. Thus, the total power loss is equal to the sum of the power loss of the circuit breaker and all the corresponding mounting accessories.

	Rating In (A)	P/MCCB 3P or 4P (W)	Additional P/ accessory kit (W)			Rear connection	Straight bar	Spreader	Plug-in/ Withdr.		
			RCD add- on block	External cable terminal							
				1 wire	2 wires					6 wires	
P160 TM	25	19.5	-	0.05	-	0.04	0.58	0.14	0.12	0.53	
	32	27		0.08		0.07	0.95	0.23	0.20	0.86	
	40	27.9		0.12		0.11	1.48	0.35	0.31	1.34	
	63	10.5		0.30		0.28	1.31	0.88	0.77	1.95	
	80	17.7		0.48		0.46	2.12	1.42	1.24	3.15	
	100	20.1		0.75		0.71	3.31	2.21	1.93	4.92	
	125	32.1		1.17		1.12	5.18	3.46	3.02	7.50	
	160	42.3		1.92		1.83	8.48	5.67	4.95	10.4	
P250 TM	50	15	3.2	0.18	0.20	0.20	0.56	0.17	0.20	0.4	
	63	13.95		0.29	0.32	0.32	0.89	0.26	0.31	0.7	
	100	18		0.72	0.82	0.82	2.23	0.66	0.78	1.7	
	125	27.9	5.6	1.13	1.28	1.28	3.49	1.03	1.22	2.6	
	160	29.1		1.84	2.09	2.09	5.71	1.69	2.00	4.2	
	200	36		17.75	2.88	2.69	3.26	8.93	2.64	3.12	6.6
	250	50.7			4.5	5.1	4.2	13.95	4.08	4.80	10.3
P160 electronic	40	1.68	-	0.12	-	0.11	1.48	0.35	0.31	1.34	
	100	10.5		0.75		0.71	3.31	2.21	1.93	4.92	
	160	27		1.92		1.83	8.48	5.67	4.95	10.4	
P250 electronic	40	1.2	3.2	0.12	0.13	0.11	0.56	0.17	0.20	0.4	
	100	7.2		0.72	0.82	0.67	2.23	0.66	0.78	1.7	
	160	18.4	5.6	1.84	2.09	1.72	5.71	1.69	2.00	4.2	
	250	45	12.75	4.5	5.1	4.2	13.95	4.08	4.80	10.3	
P630 electronic	250	36.8	13.6	82.5	50.63	-	7	4.8	5.4	11.4	
	400	90	21.7	211.2	129.6		17.9	12.6	13.8	29.1	
	630	175.8	34.3	-	321.49		44	16.7	19	58.5	

Dimensions and connections

	Page
01 Circuit breakers and RCD add-on block	112
02 Circuit breakers plug-in	119
03 Circuit breakers withdrawables	122
04 Handles and motor operators	111
05 Front panel cut-outs	131
06 Power connections	134
07 Panel display	145

Dimension P160

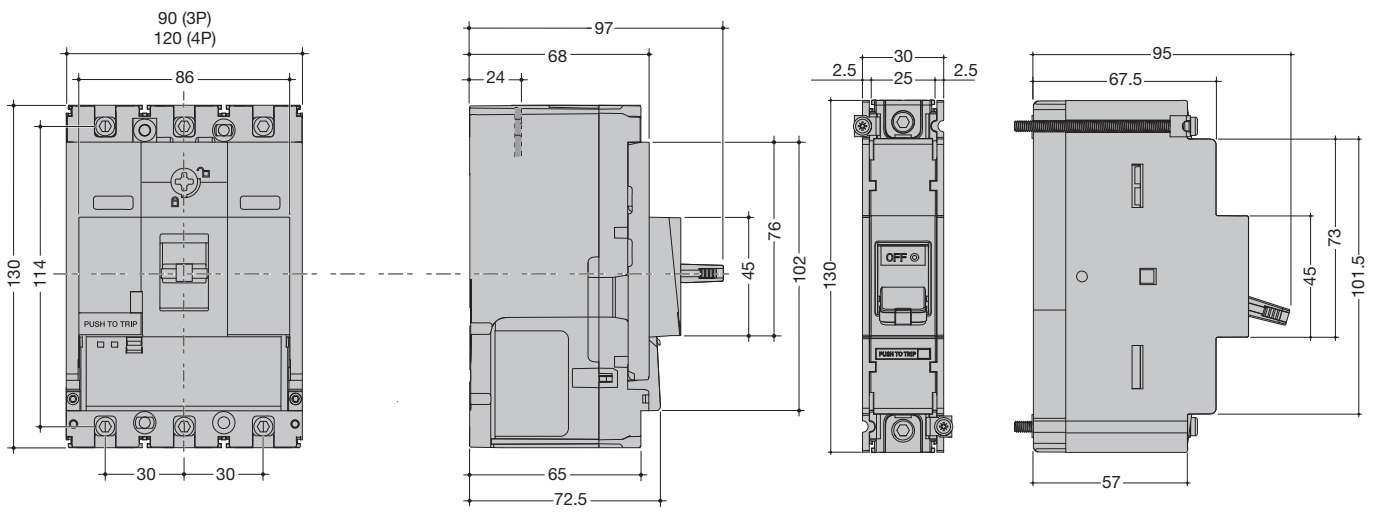

Dimension P250

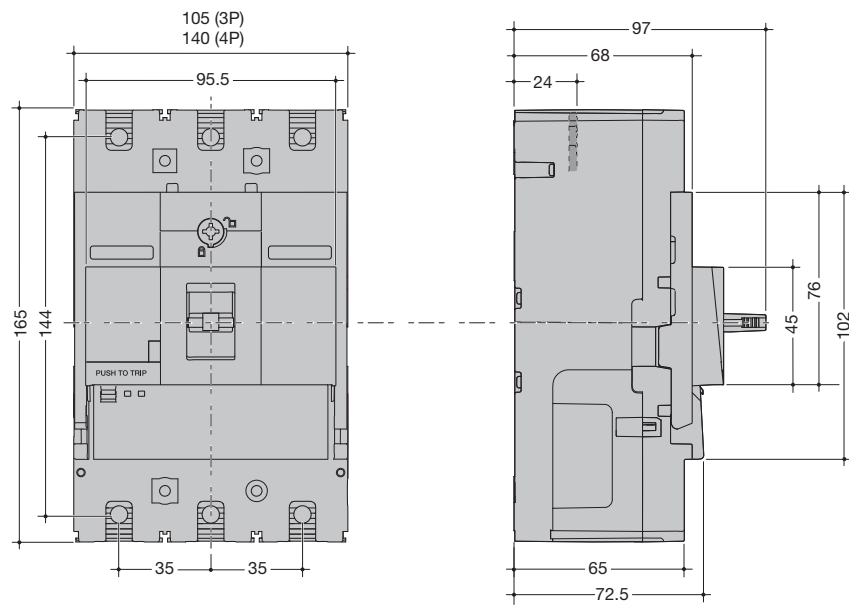

Dimensions in mm

Dimension P630

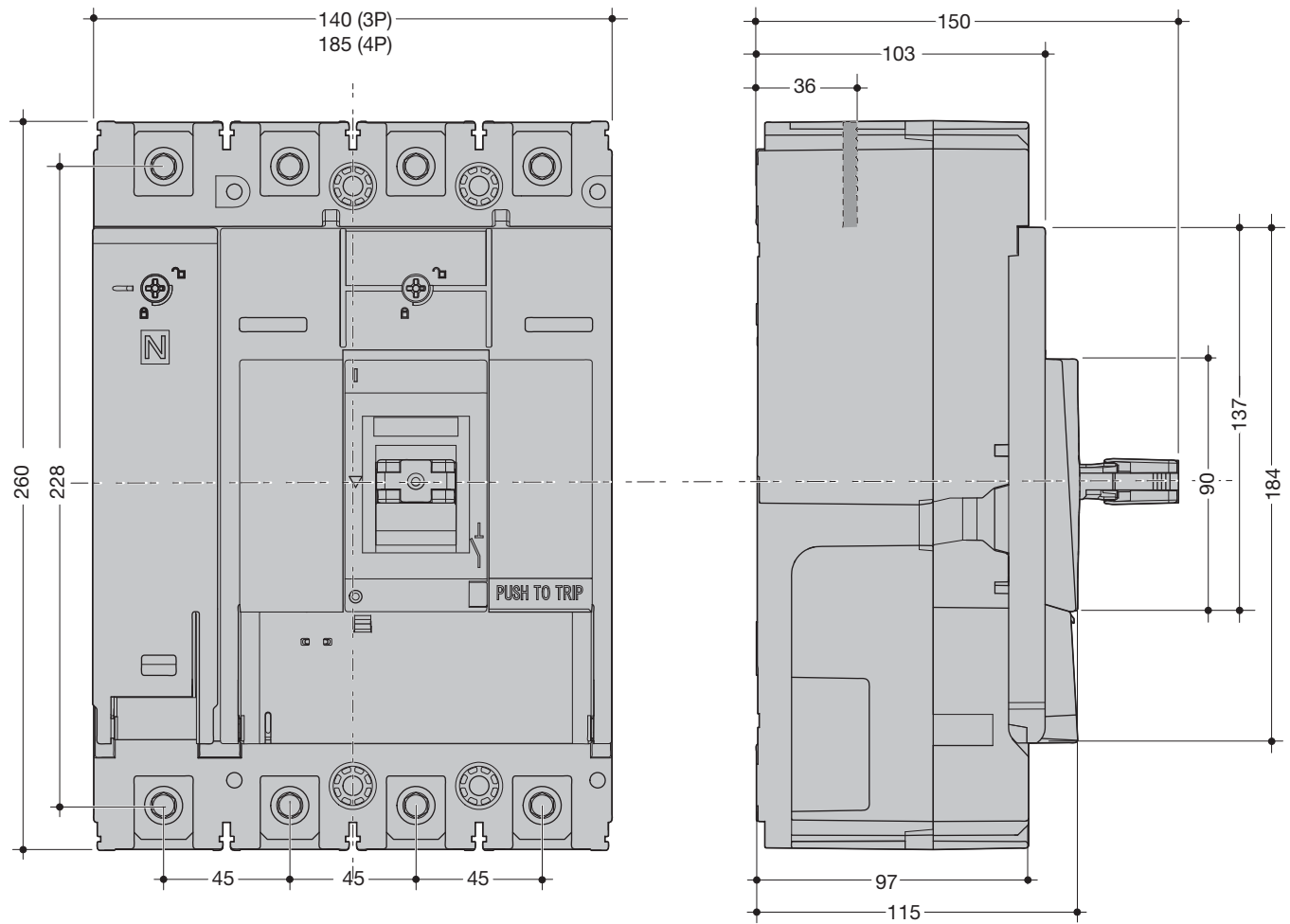

Dimensions in mm

Dimension RCD Add-on block P250



Dimension RCD Add-on block P630

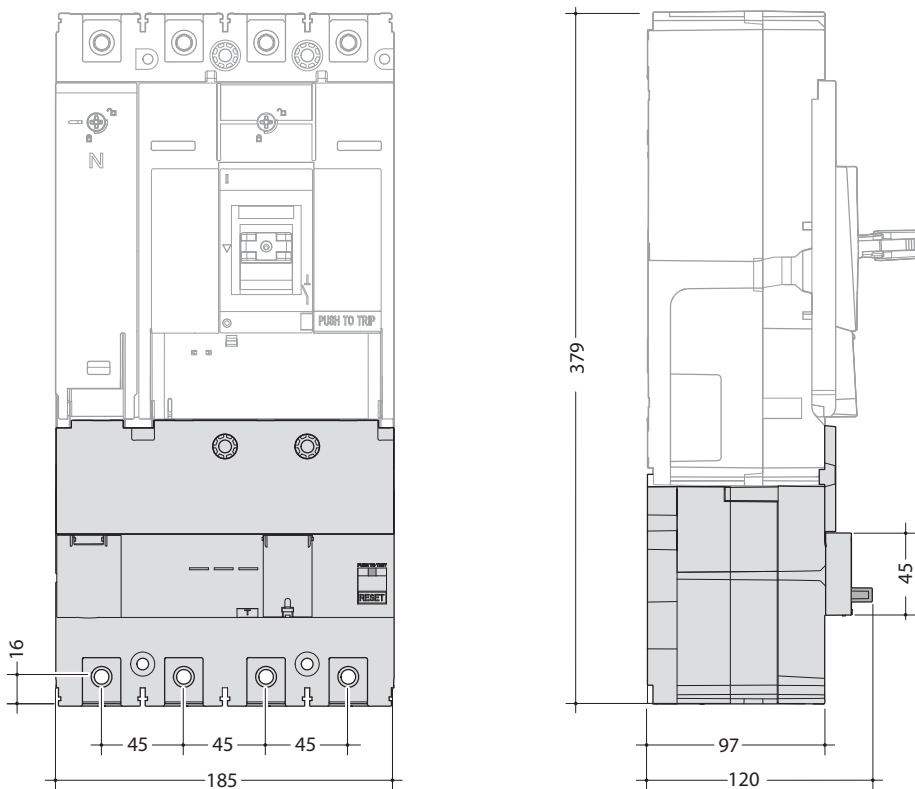

Dimensions in mm

P160 back plate drilling pattern

3P

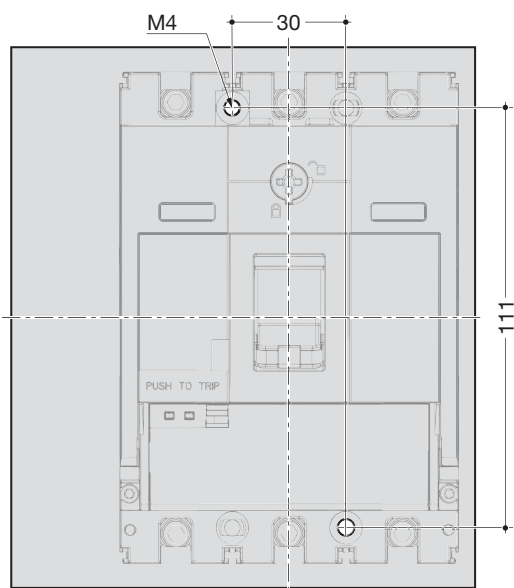

4P

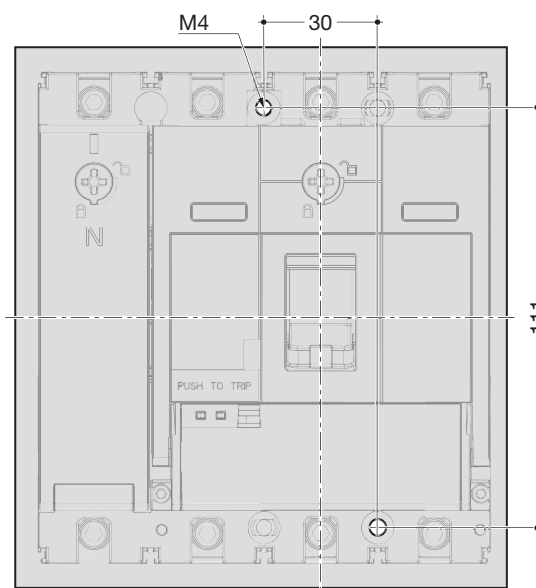

P250 back plate drilling pattern

3P

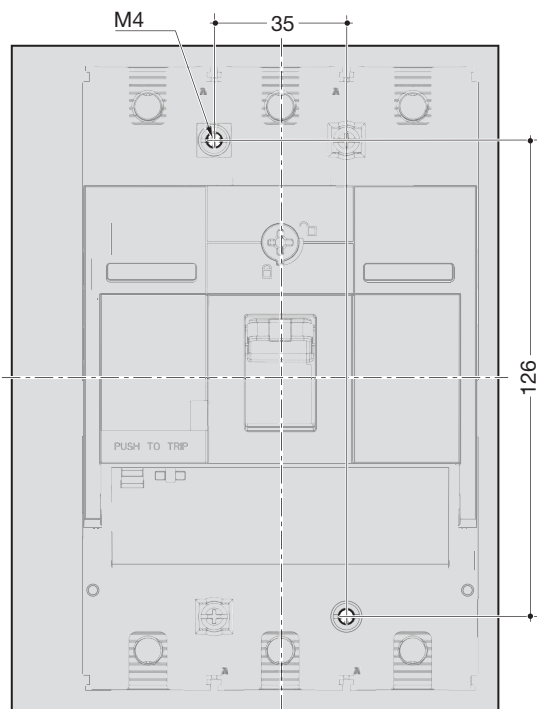

4P

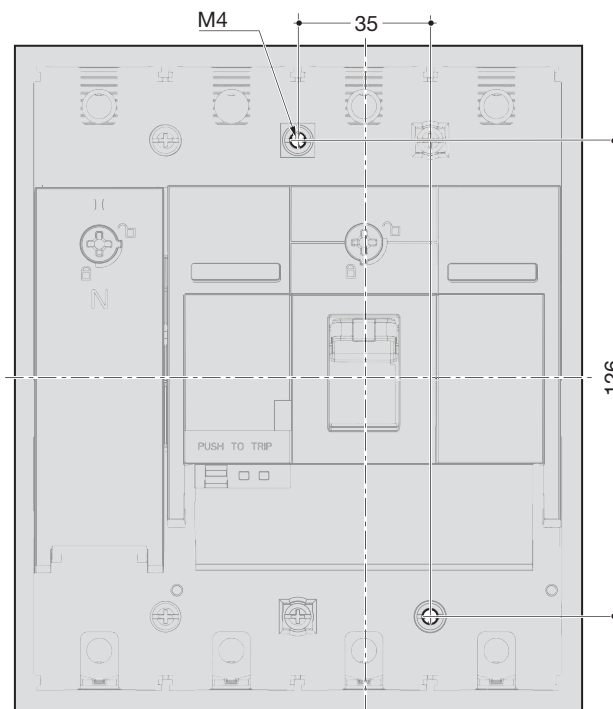

P630 back plate drilling pattern

3P

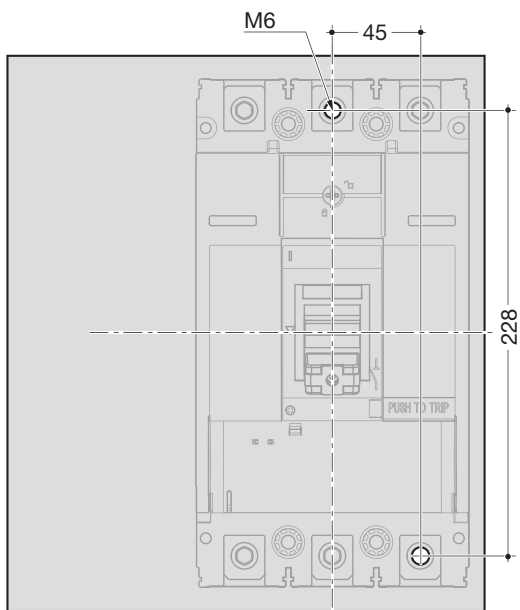

4P

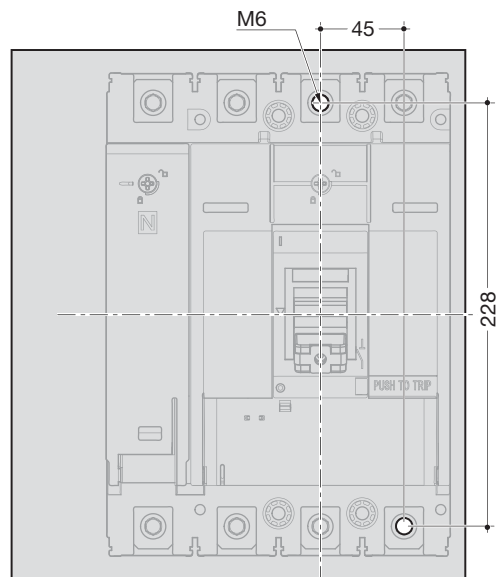

Dimensions in mm

P160 rear connection back plate drilling pattern

3P

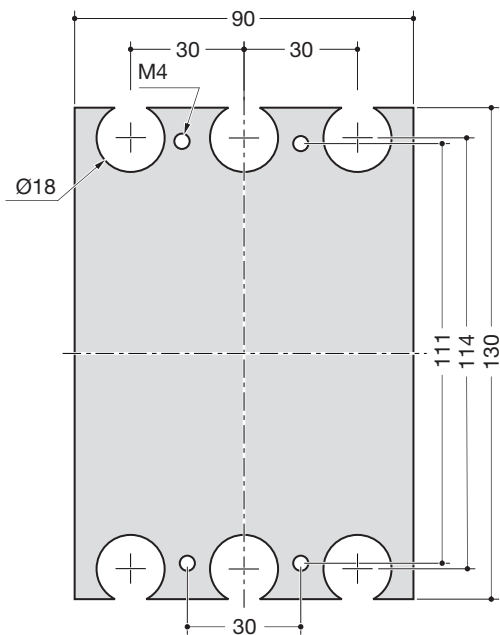

4P

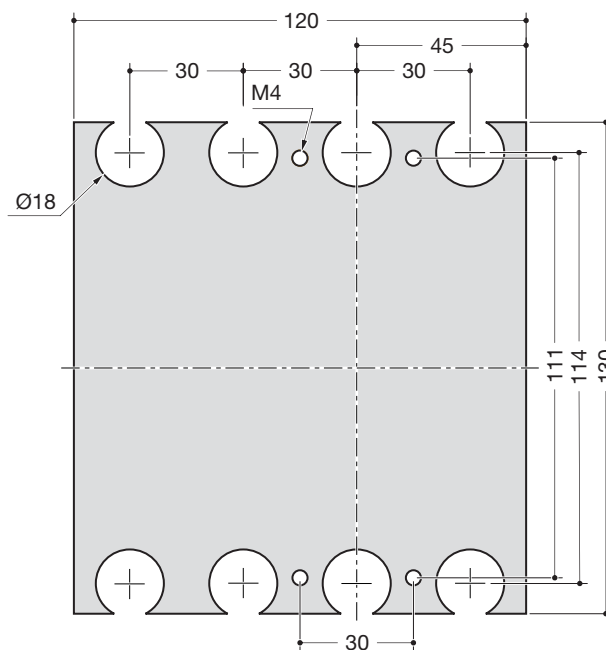

P250 rear connection back plate drilling pattern

3P

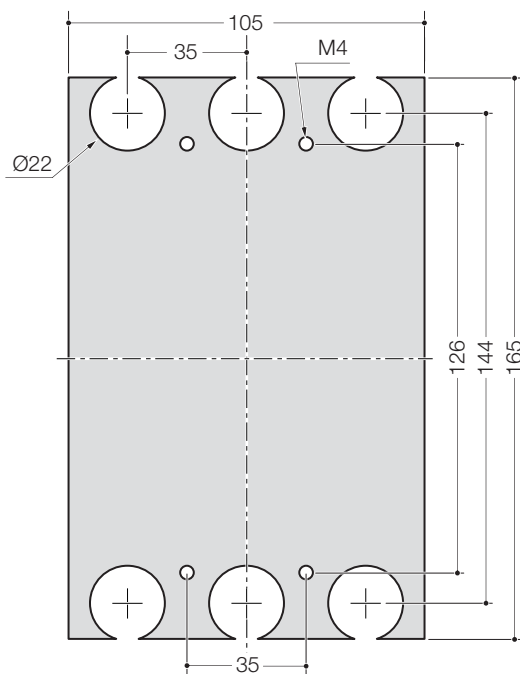

4P

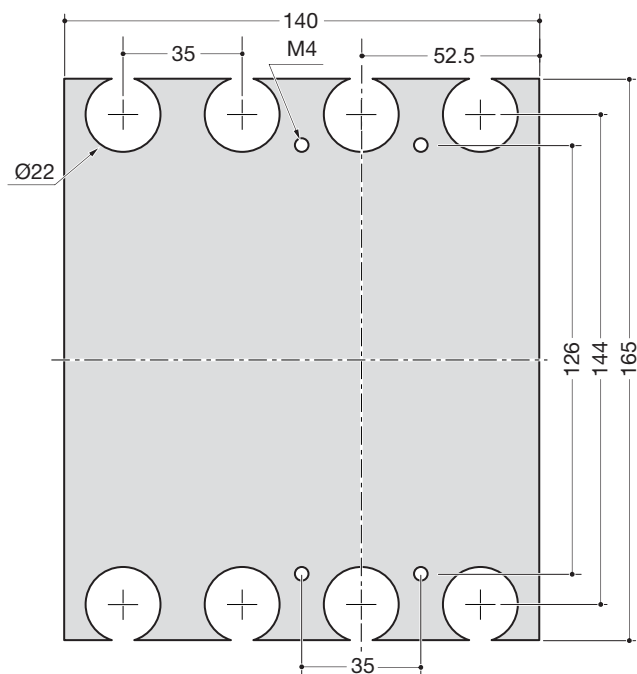

Dimensions in mm

Data is subject to errors and technical modifications.

P630 rear connection back plate drilling pattern

3P

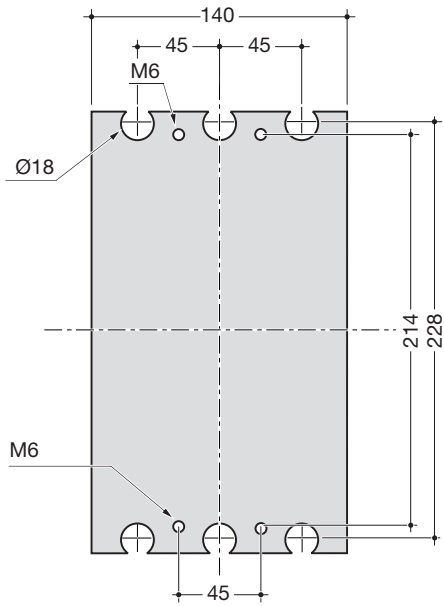

4P

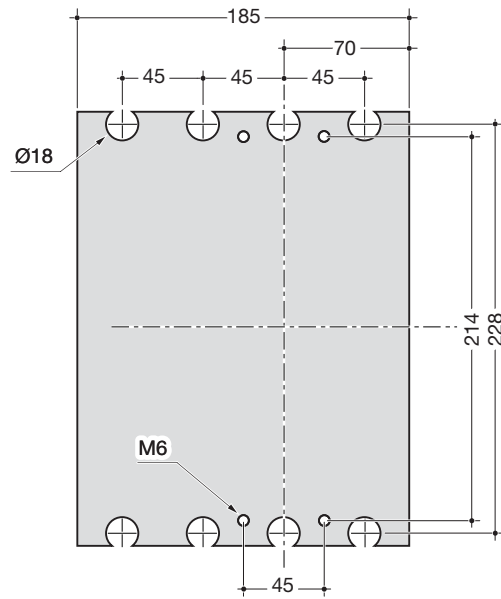

P160 DIN rail adaptor

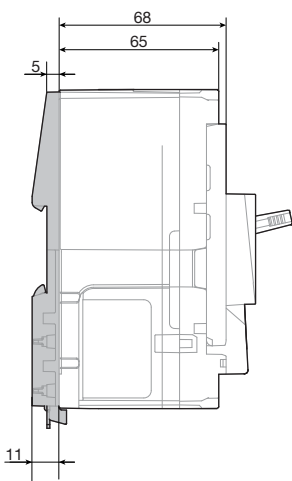

P250 DIN rail adaptor

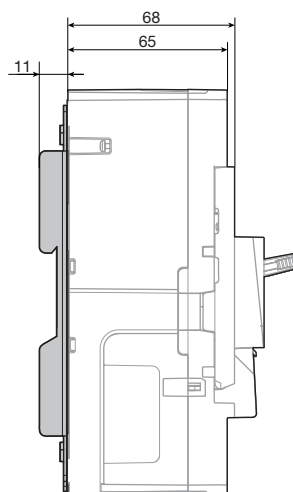

Dimensions in mm

P160 plug-in kit drilling pattern for U plate
3P + 4P

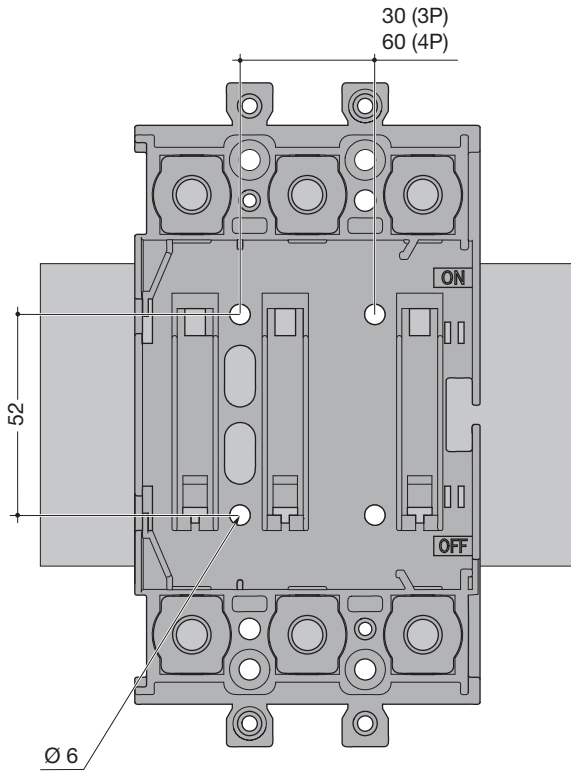

P160 plug-in kit drilling pattern for solid back plate
3P + 4P

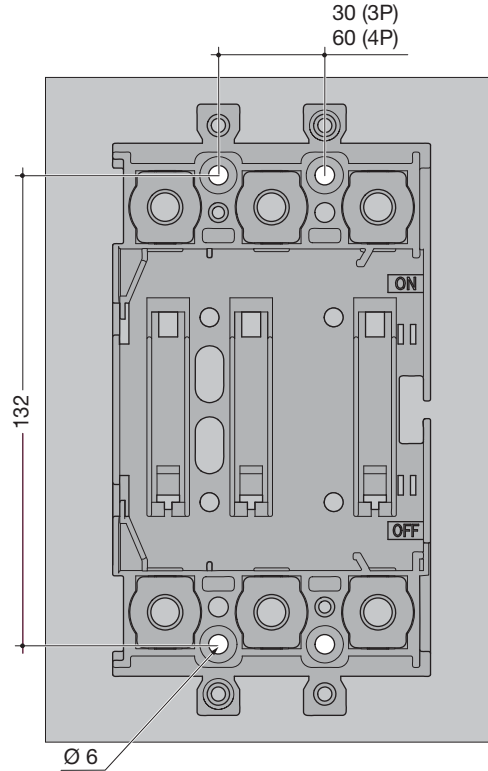

P160 plug-in kit drilling pattern for flush mounting
3P + 4P

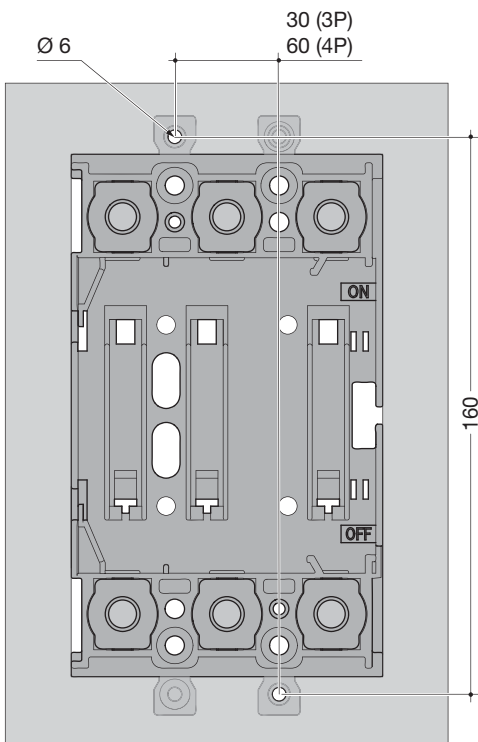

Dimensions in mm

P250 plug-in kit drilling pattern for U plate

3P + 4P

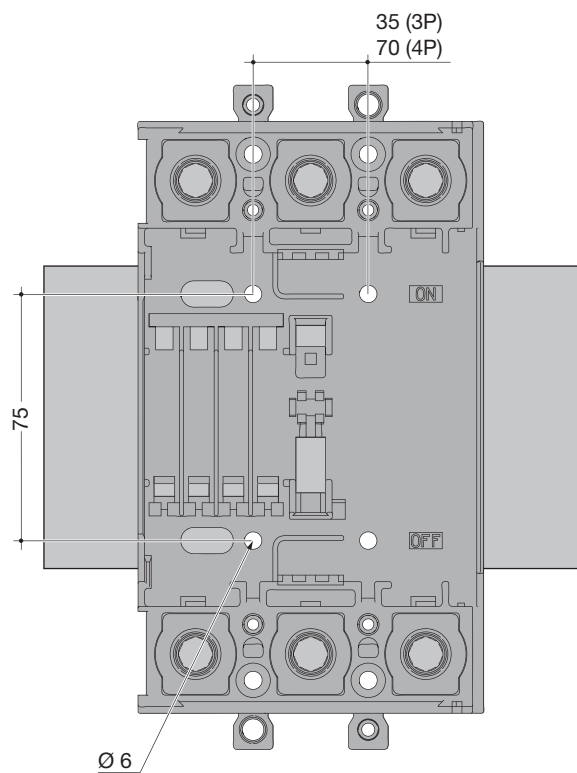

P250 plug-in kit drilling pattern for solid back plate

3P + 4P

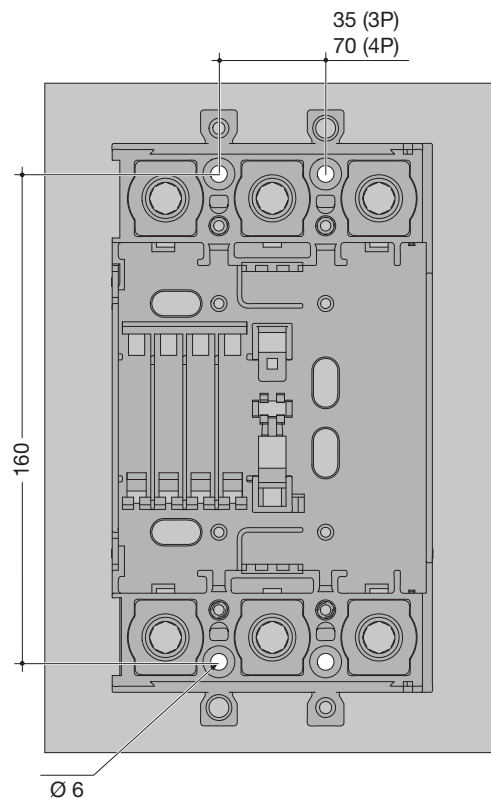

P250 plug-in kit drilling pattern for flush mounting

3P + 4P

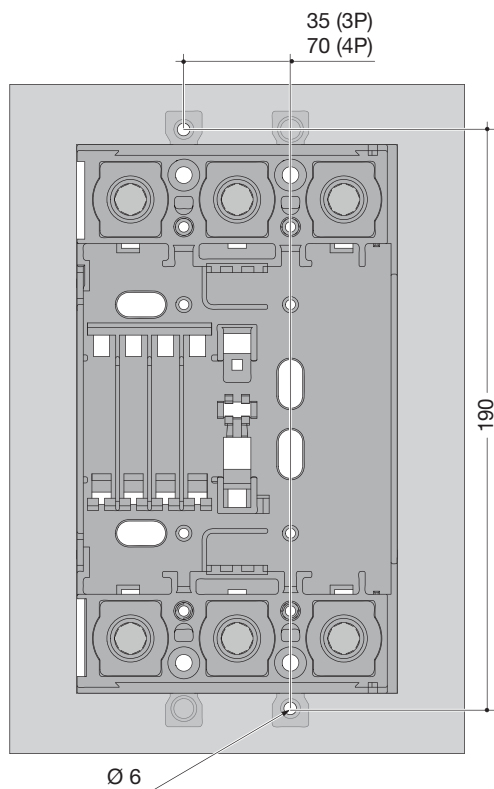

P250 circuit breaker on plug-in kit

3P + 4P

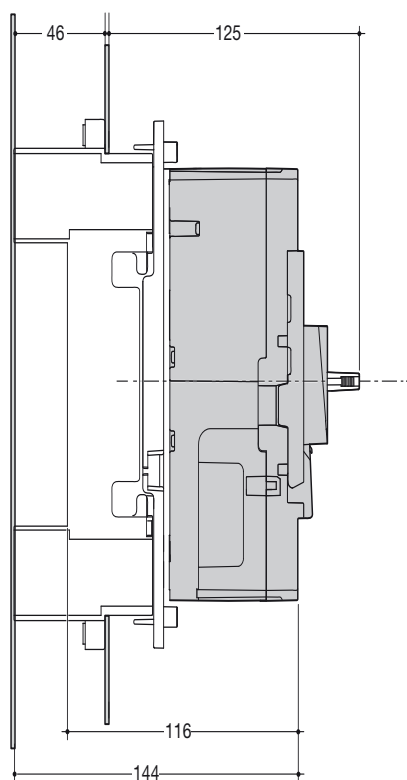

Dimensions in mm

P630 plug-in kit drilling pattern for U plate
3P + 4P

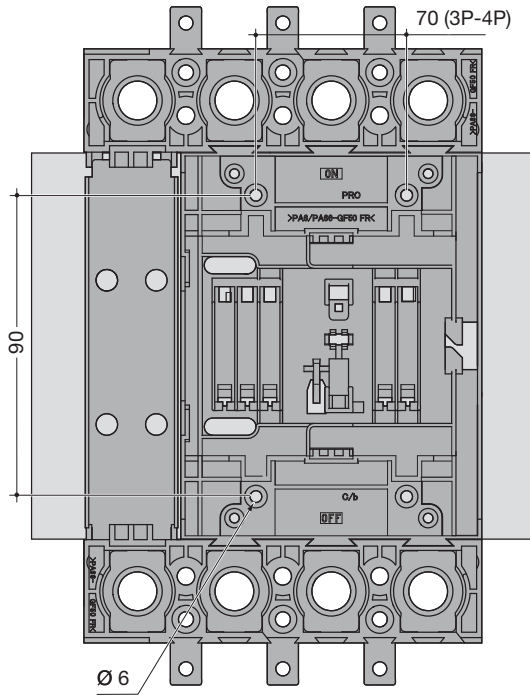

P630 plug-in kit drilling pattern for solid back plate
3P + 4P

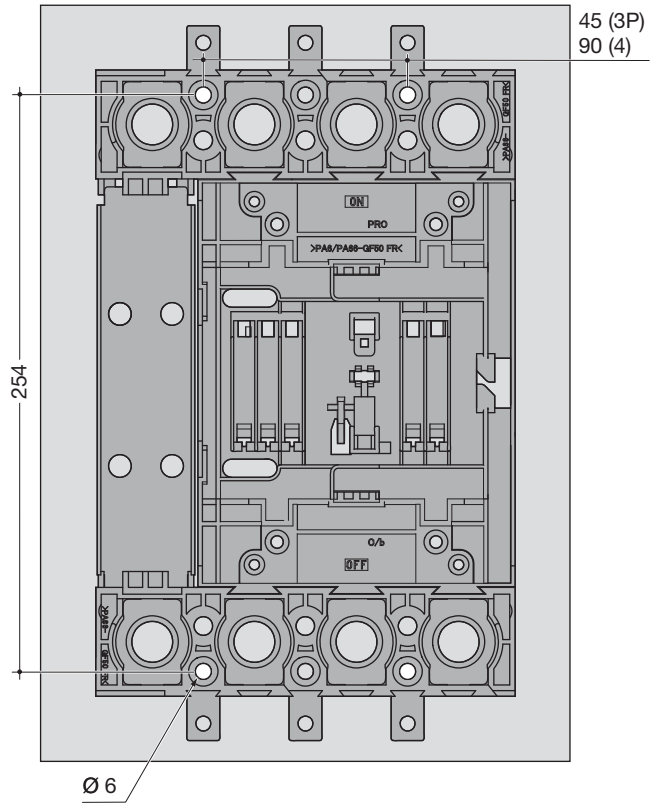

P630 plug-in kit drilling pattern for flush mounting
3P + 4P

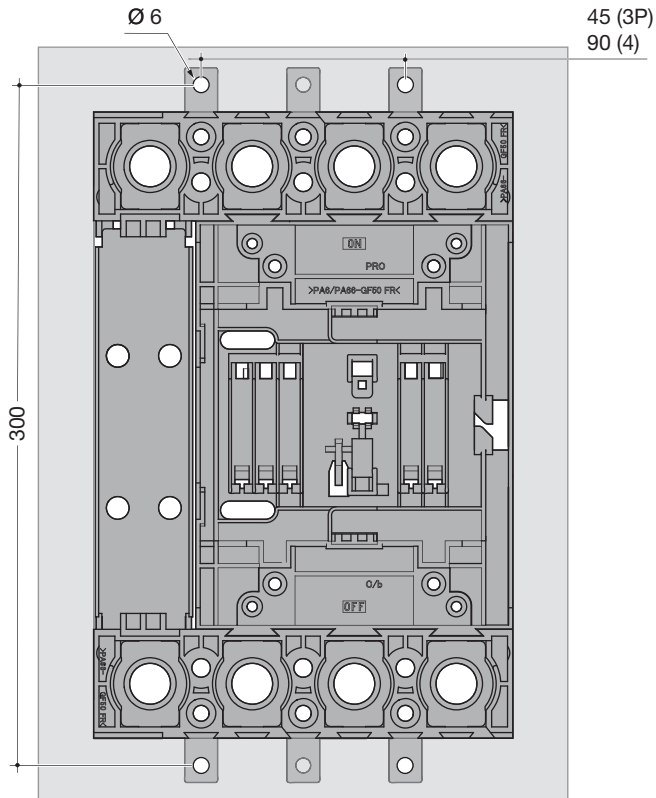

P630 circuit breaker on plug-in kit
3P + 4P

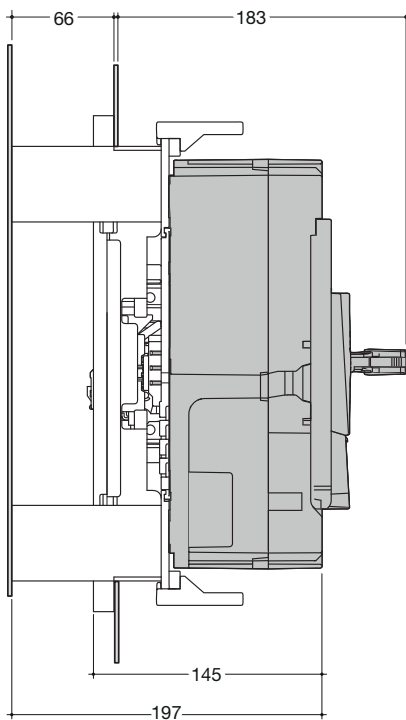

Dimensions in mm

P250 withdrawable plate drilling pattern

3P + 4P

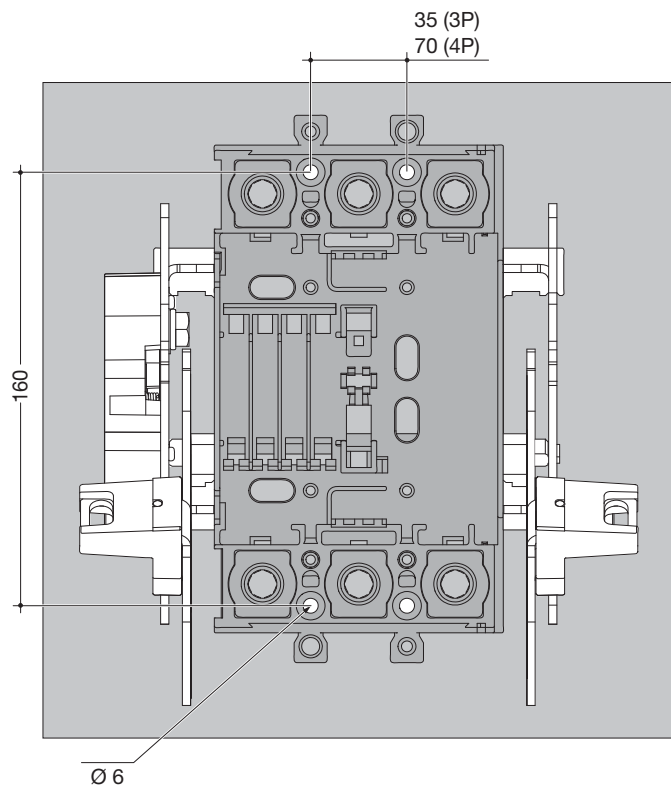

P250 circuit breaker on withdrawable plate

3P + 4P

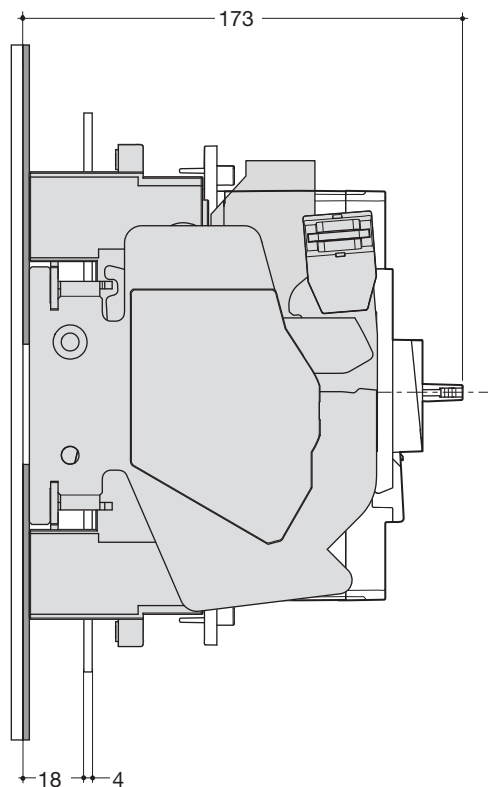

P630 withdrawable plate drilling pattern

3P + 4P

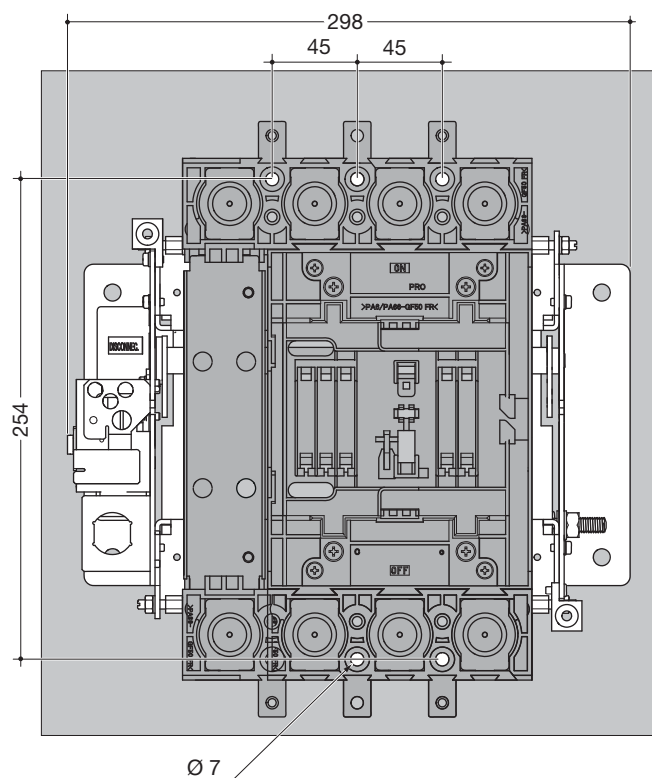

P630 circuit breaker on withdrawable plate

3P + 4P

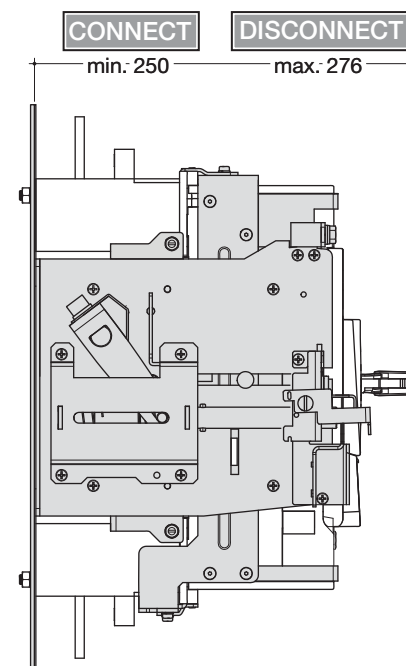

Dimensions in mm

P250 Motor operator on plug-in circuit breaker
3P + 4P

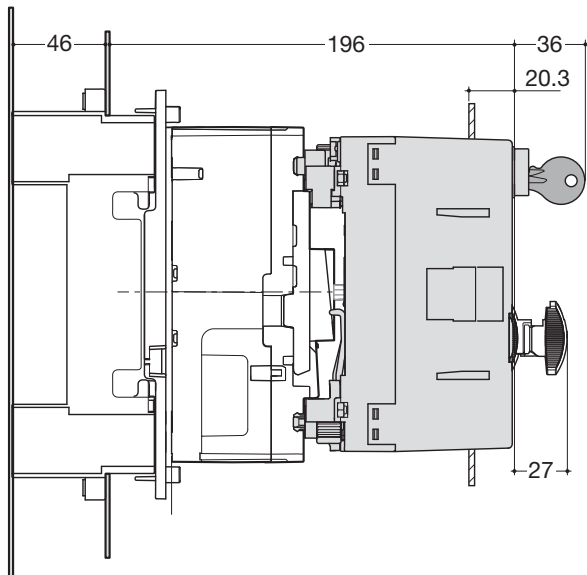

P250 Motor operator on withdrawable circuit breaker
3P + 4P

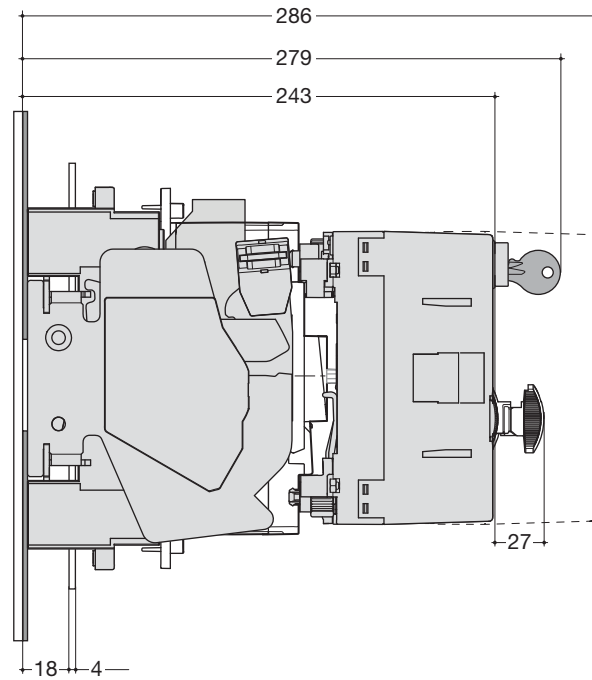

P630 Motor operator on plug-in circuit breaker
3P + 4P

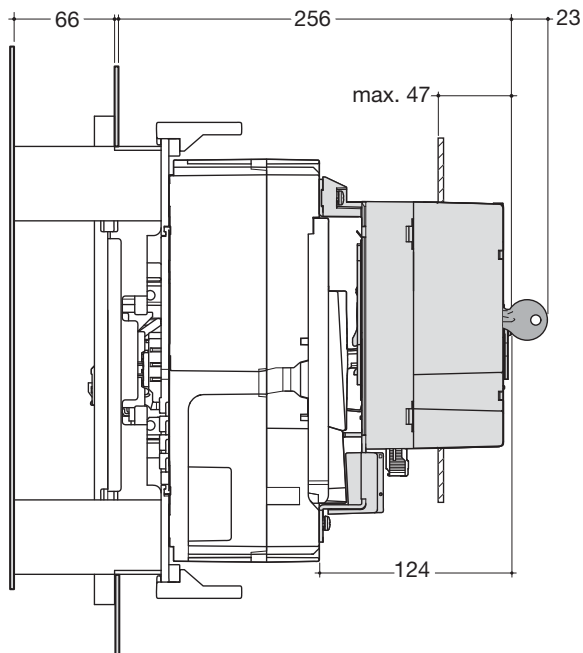

P630 Motor operator on withdrawable circuit breaker
3P + 4P

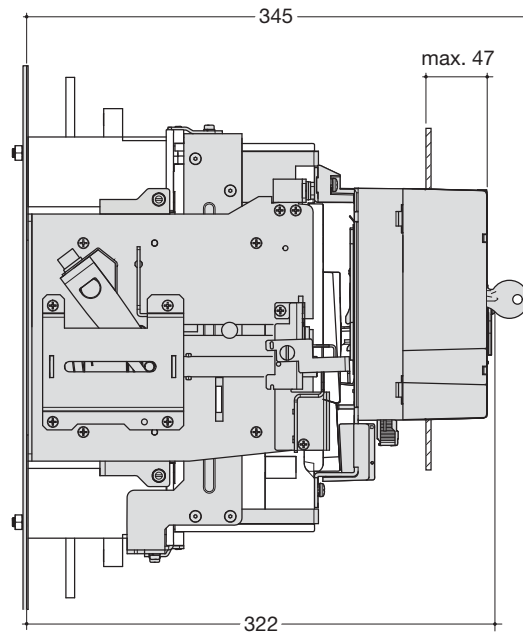

Dimensions in mm

Drawout system P630

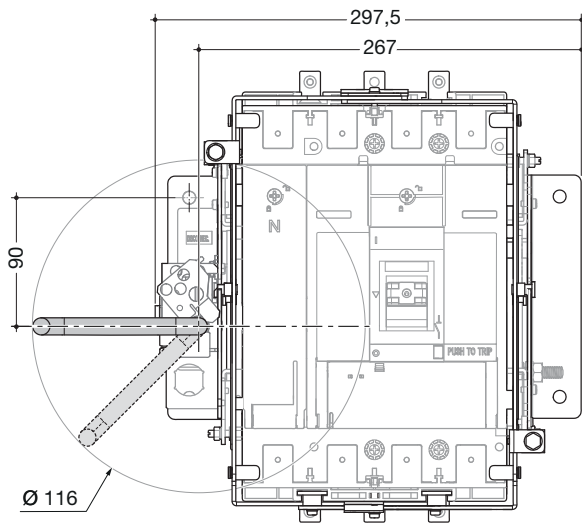

Rotary handle P160

3P

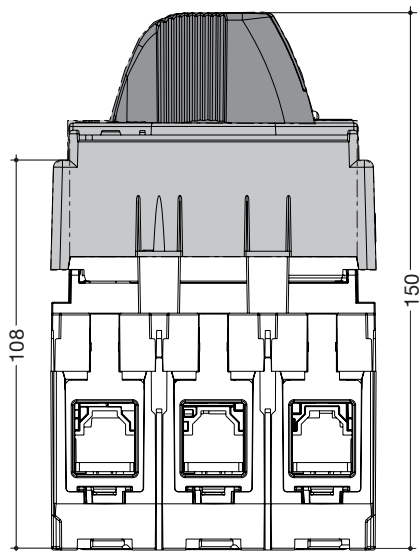

4P

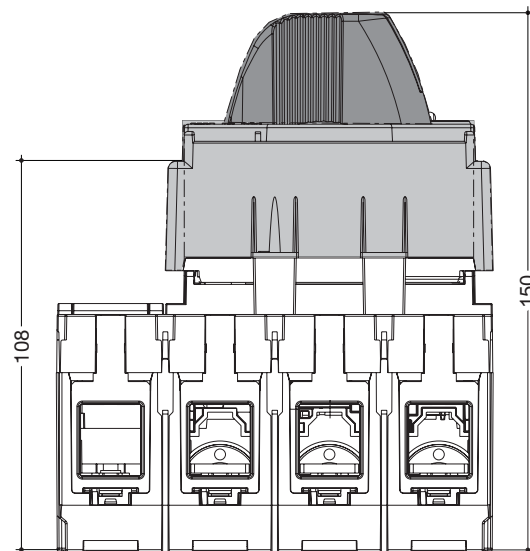

Dimensions in mm

Rotary handle P250

3P

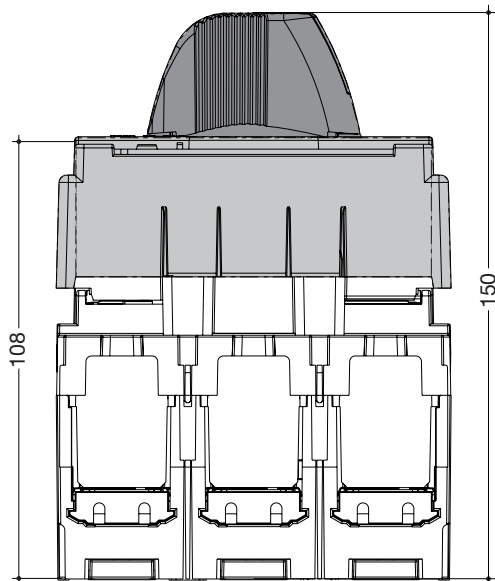

4P

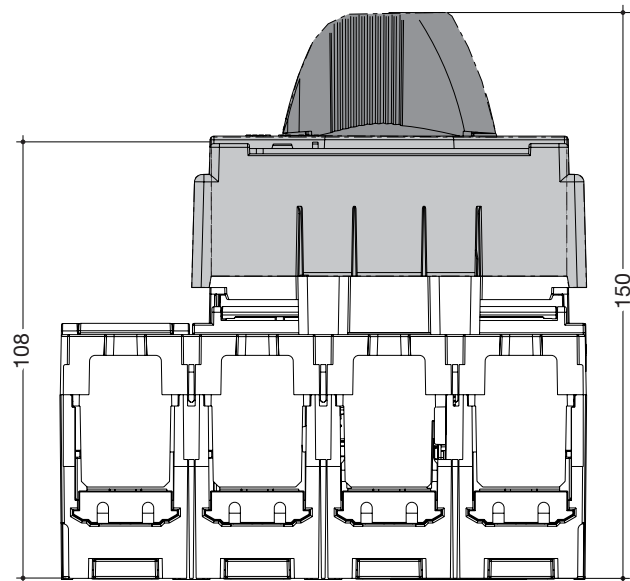

Rotary handle P630

3P

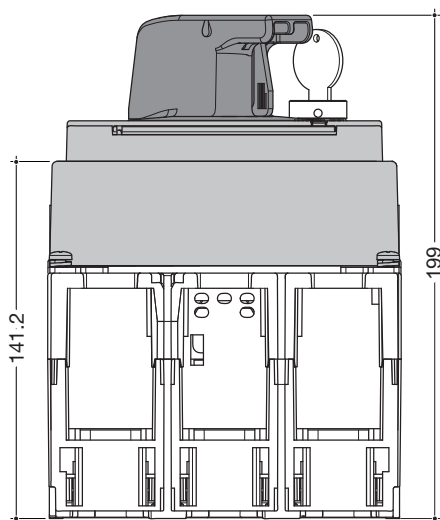

4P

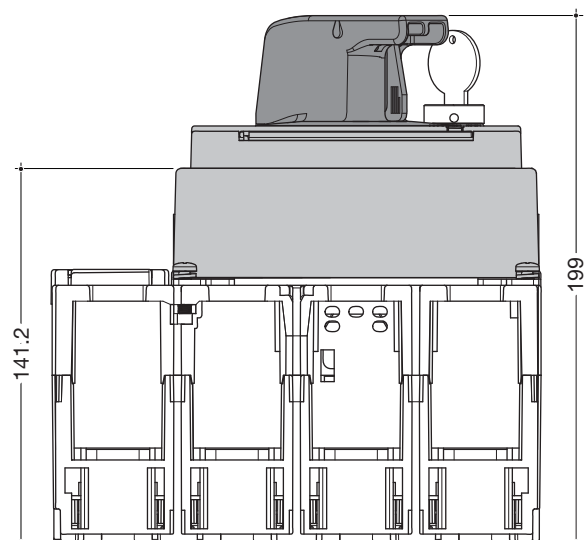

Dimensions in mm

Panel cut-out rotary handle P160

3P

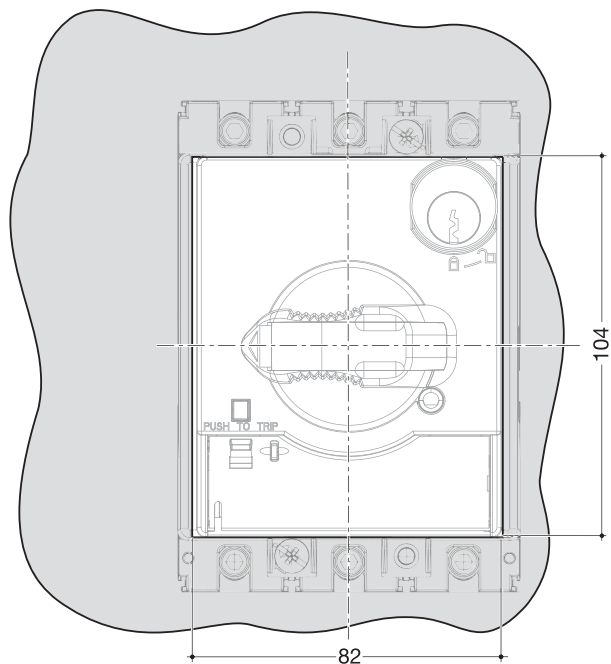

4P

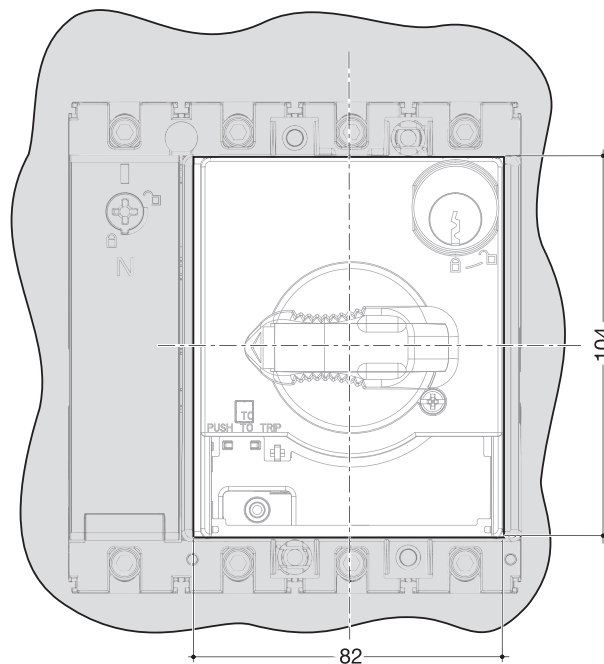

Panel cut-out rotary handle P250

3P

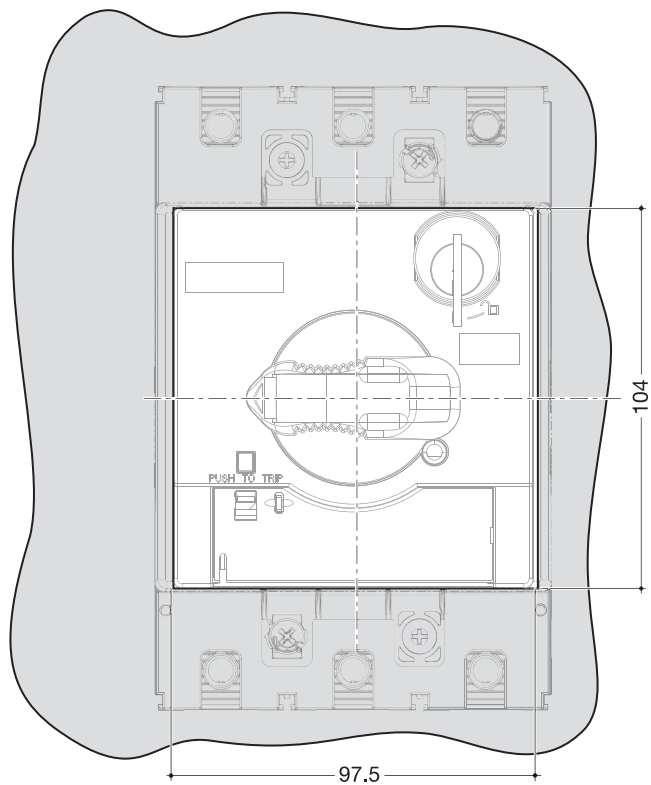

4P

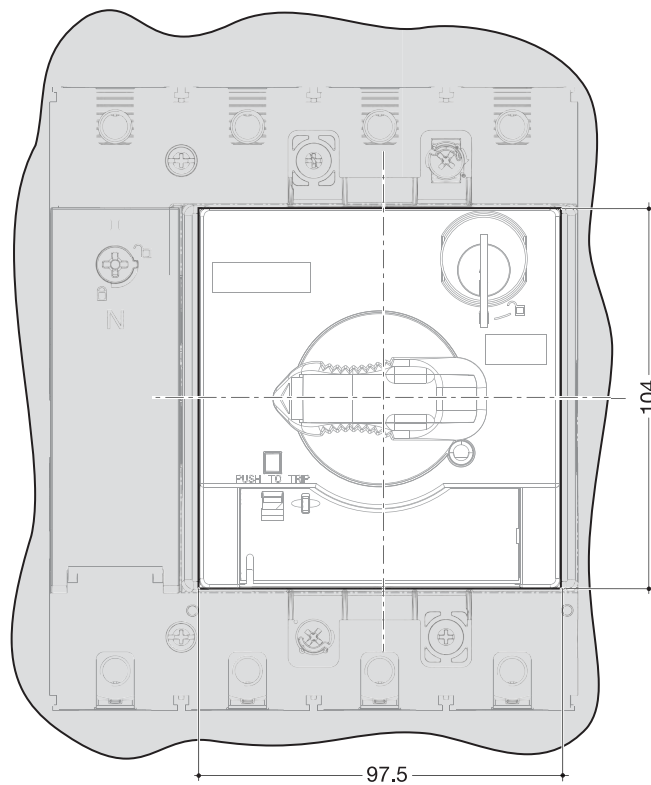

Dimensions in mm

Panel cut-out rotary handle P630

3P

4P

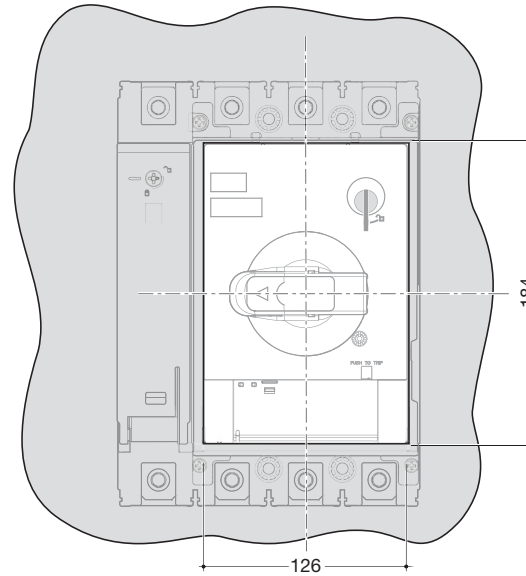
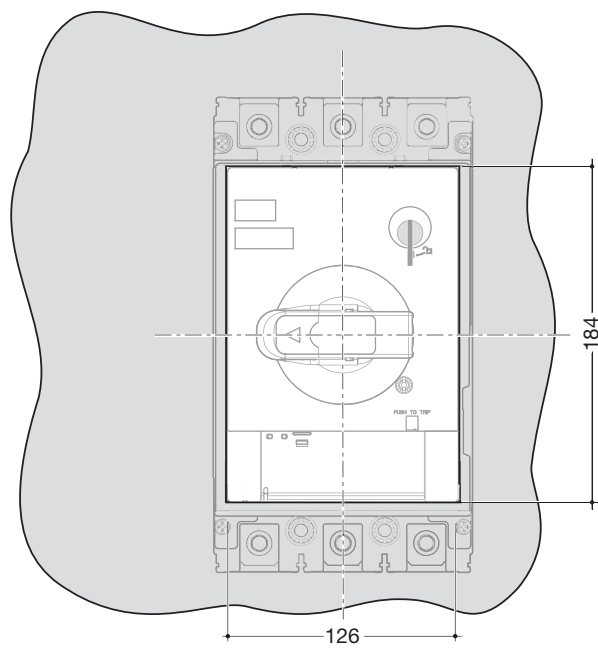

Extended rotary handle P160/P250

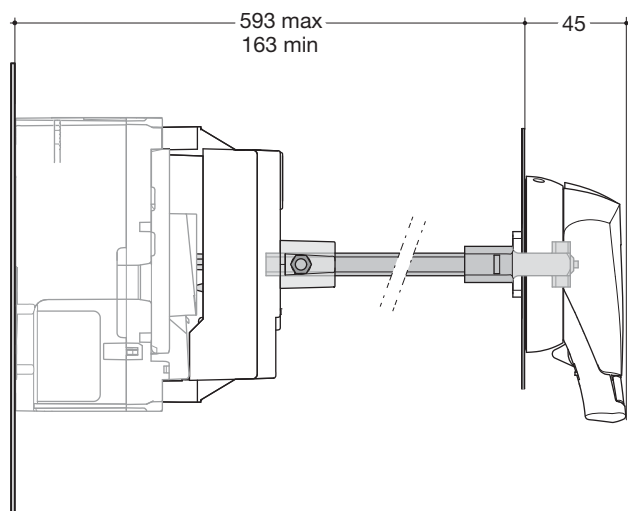

Dimensions in mm

Panel cut-out extended rotary handle P160/P250

3P

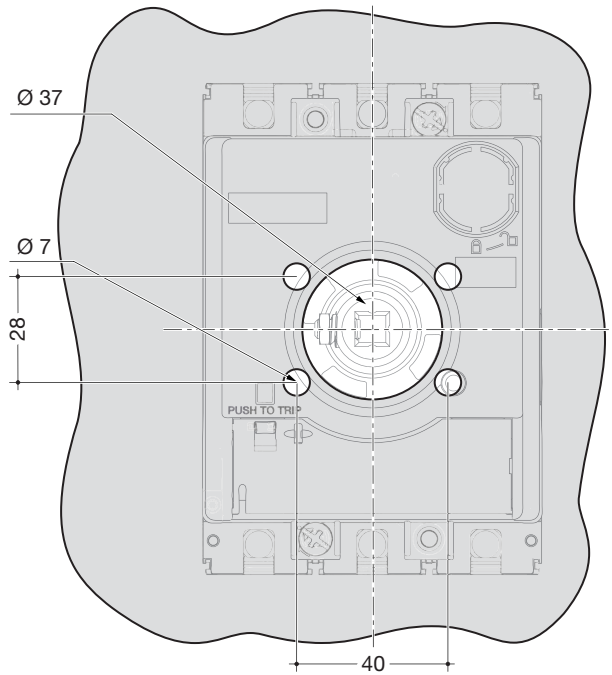

4P

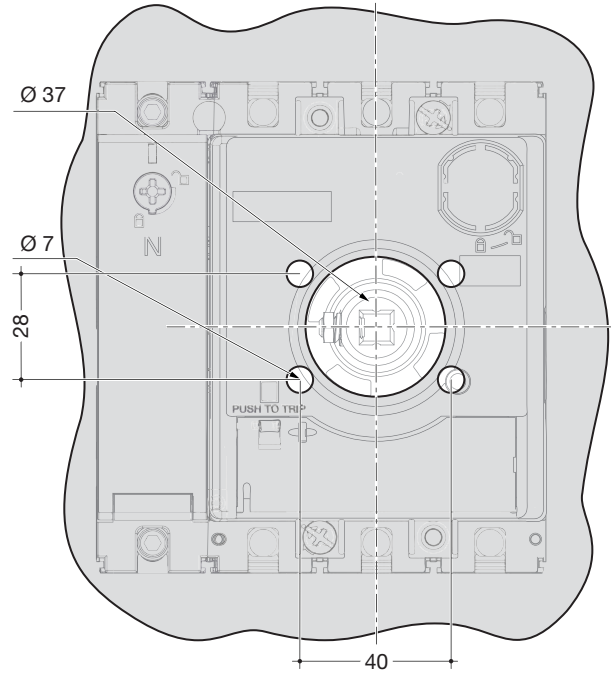

Extended rotary handle P630

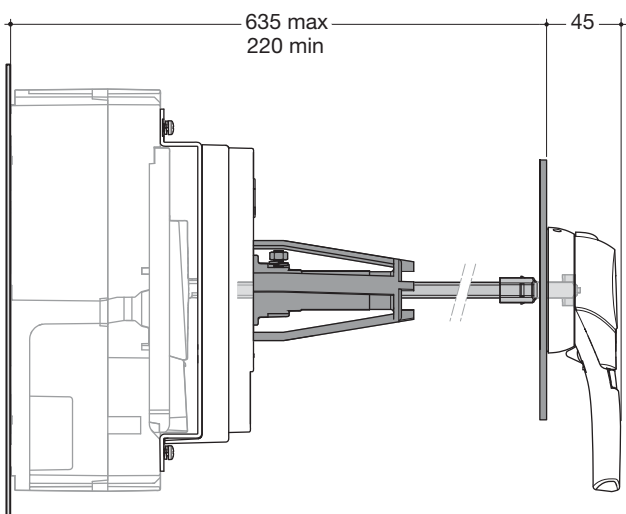

Dimensions in mm

Extended rotary handle P630 on drawout

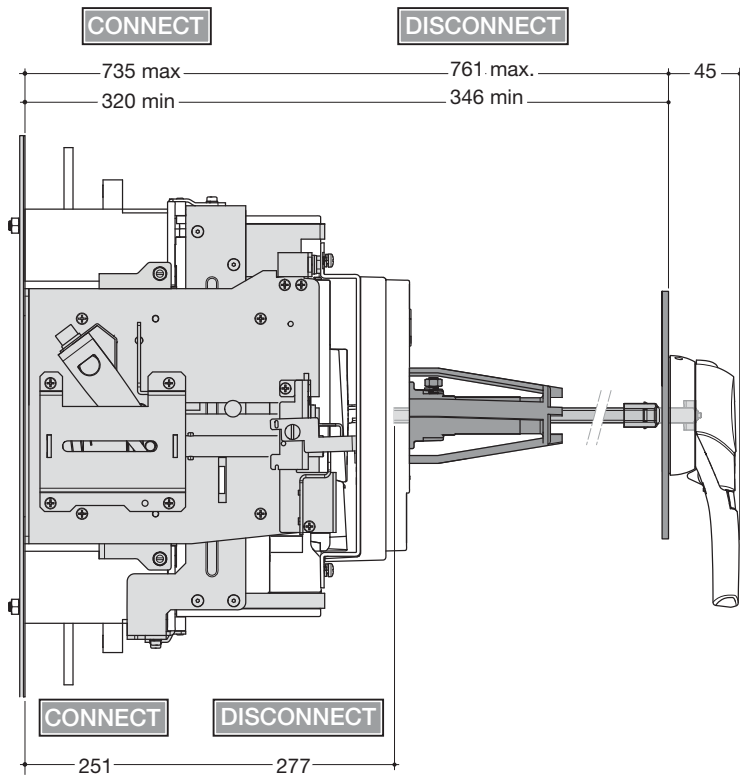

Panel cut-out extended rotary handle P630

3P

4P

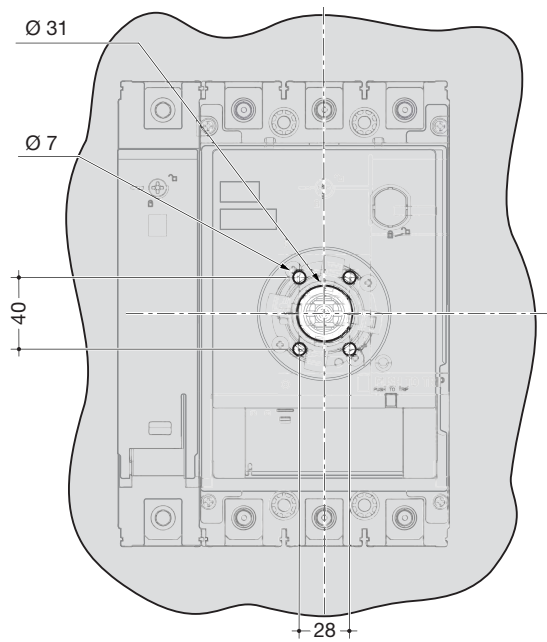
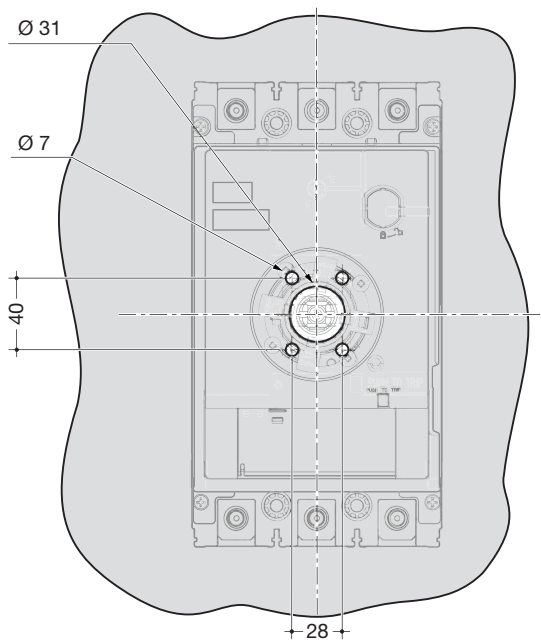

Dimensions in mm

Panel cut-out motor operator P250

3P

4P

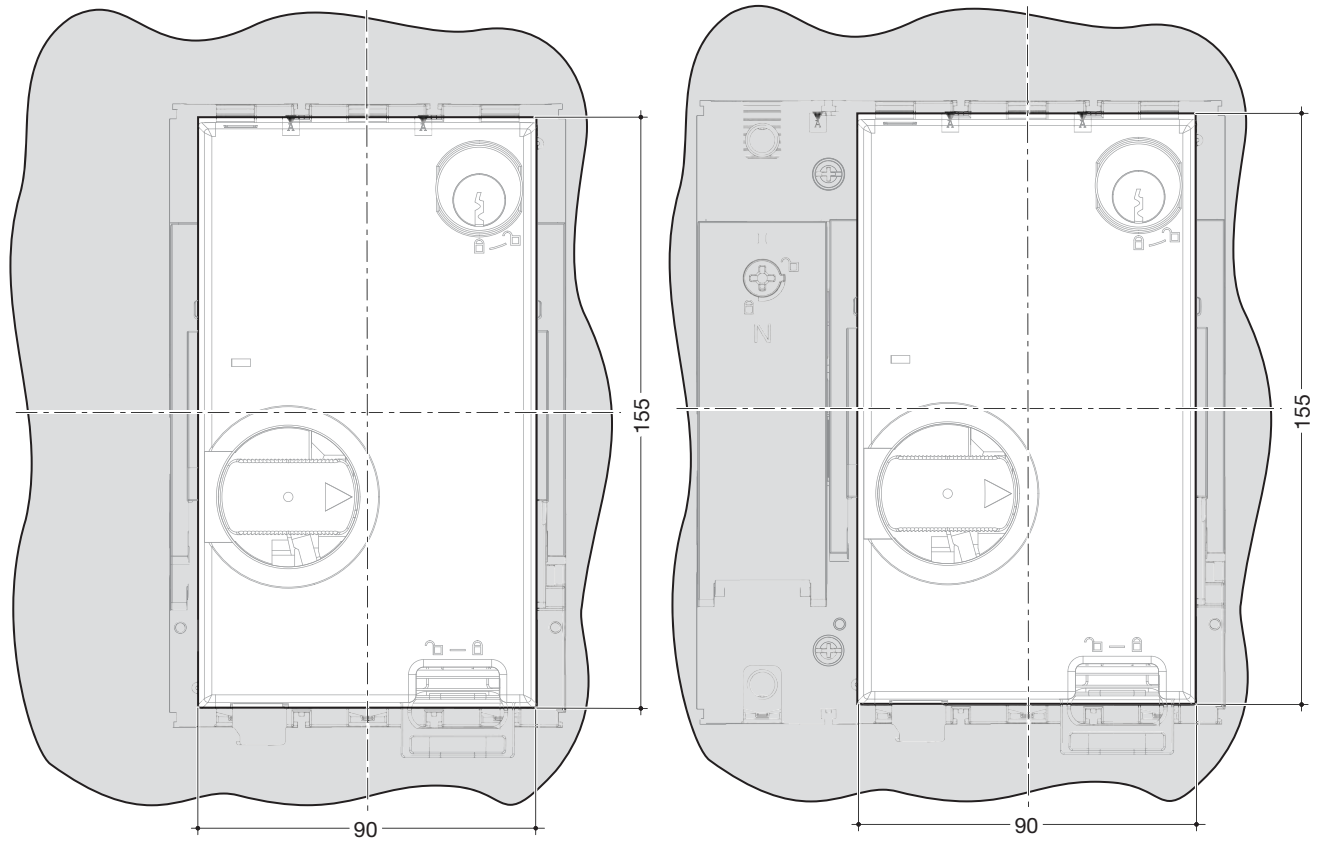

Motor operator with fixed circuit breaker P250

3P

4P

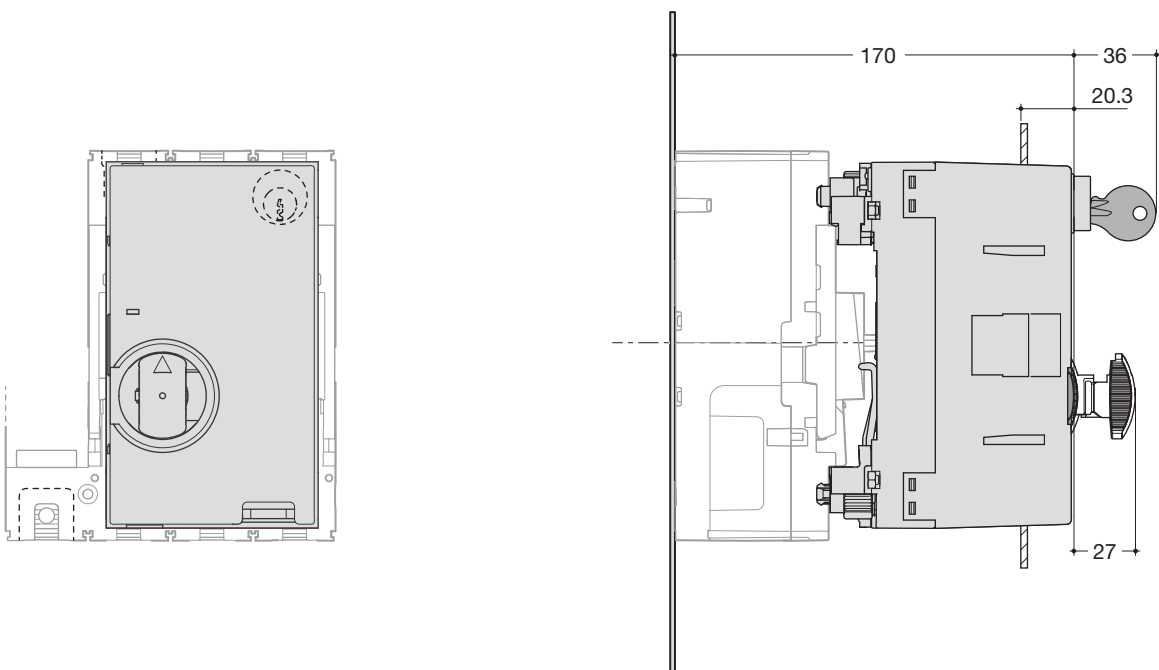

Dimensions in mm

Panel cut-out motor operator P630

3P

4P

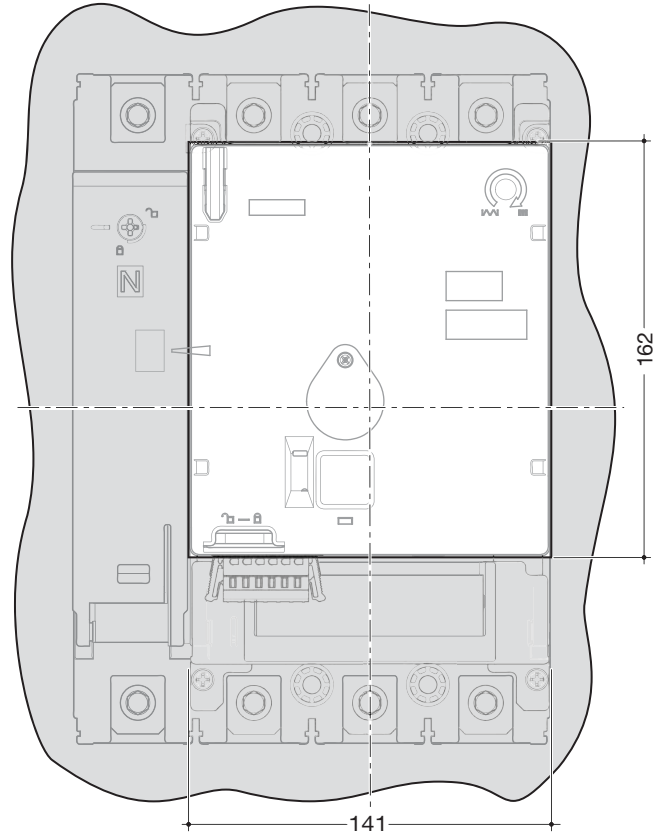
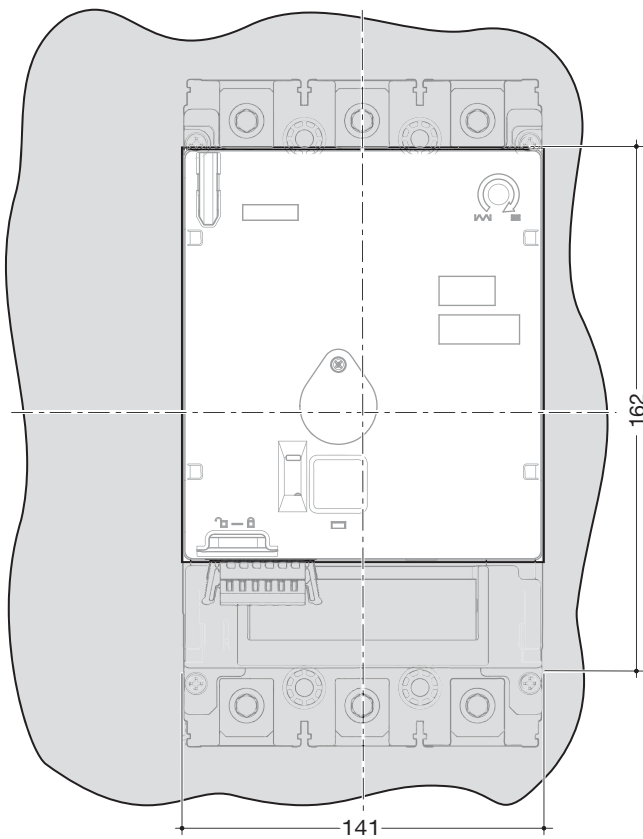

Motor operator with fixed circuit breaker P630

4P

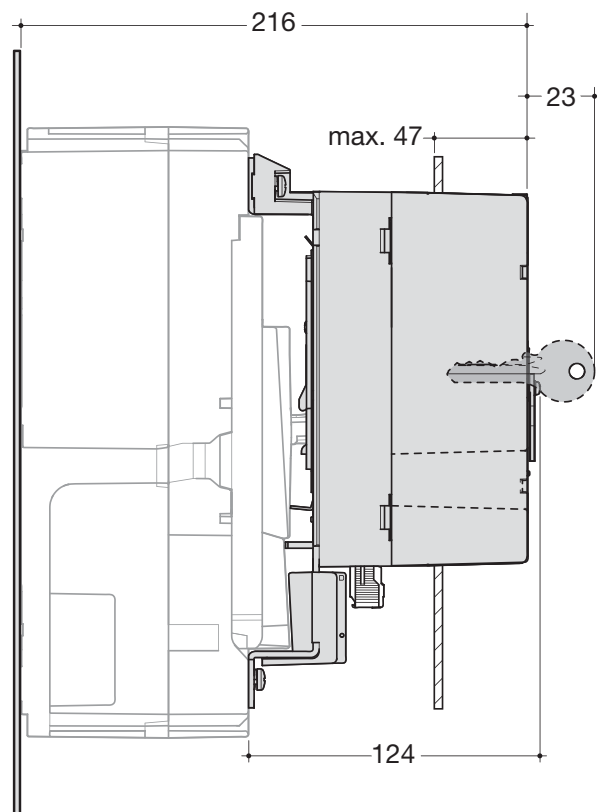
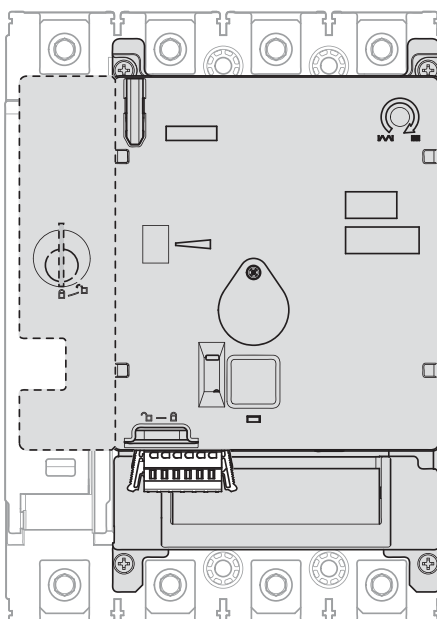

Dimensions in mm

Panel cut-out circuit breaker P160

3P

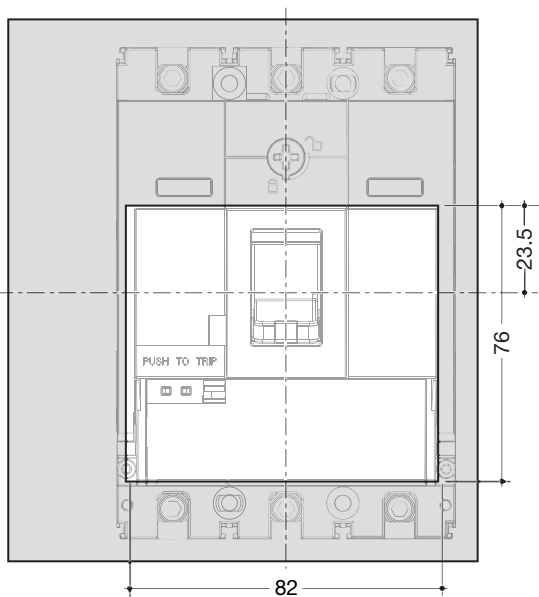

4P

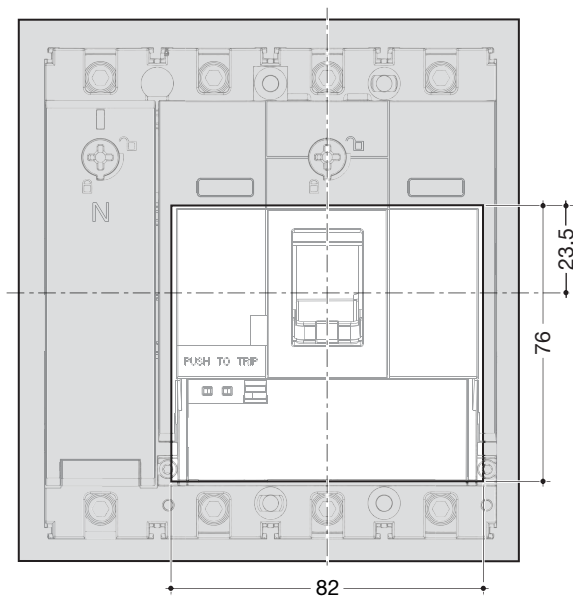

Panel cut-out circuit breaker P250

3P

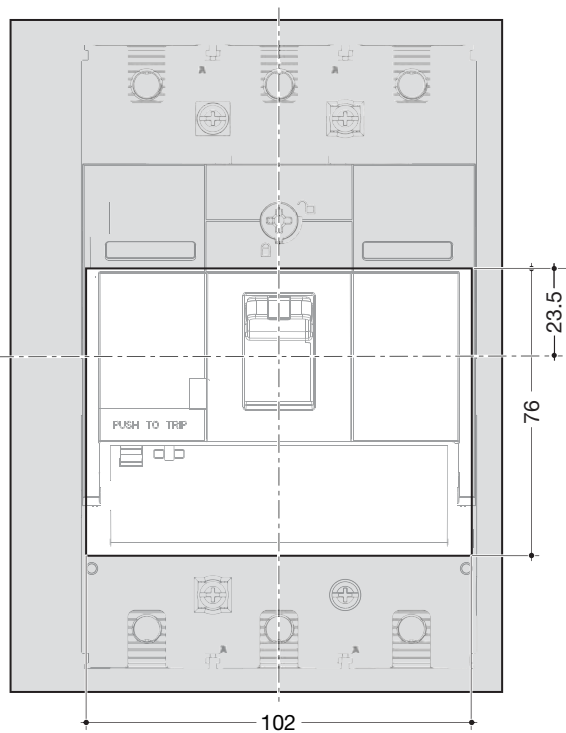

4P

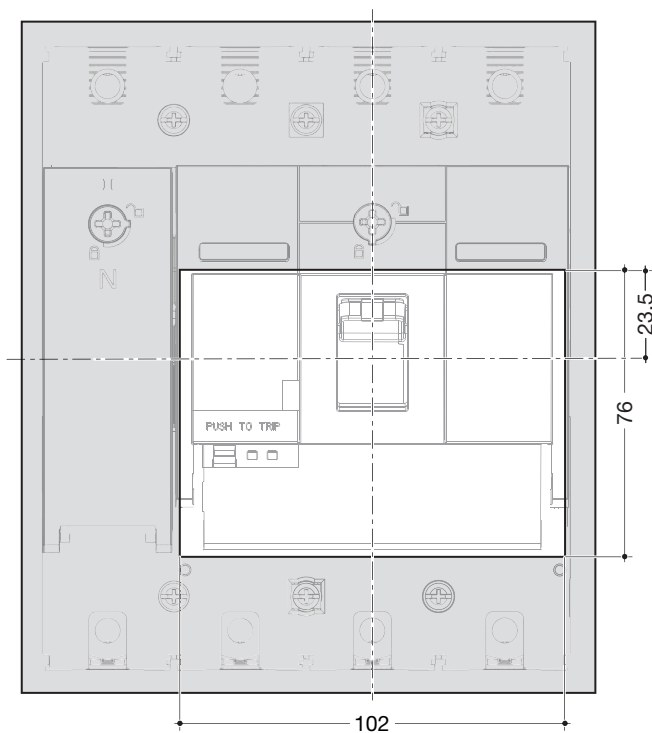

Dimensions in mm

Panel cut-out circuit breaker P630

3P

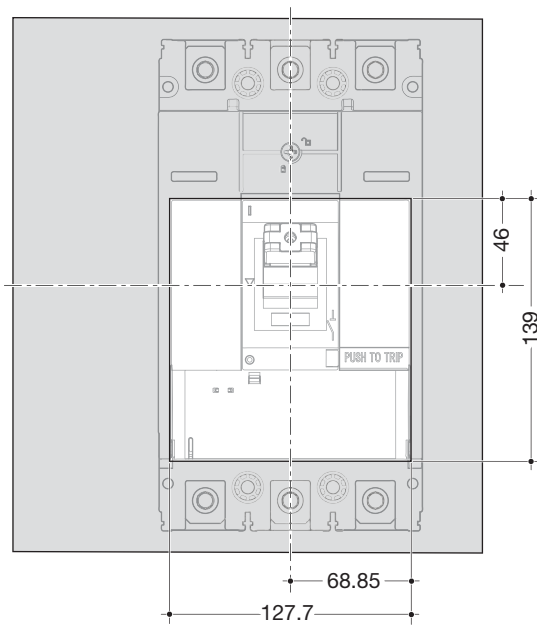

4P

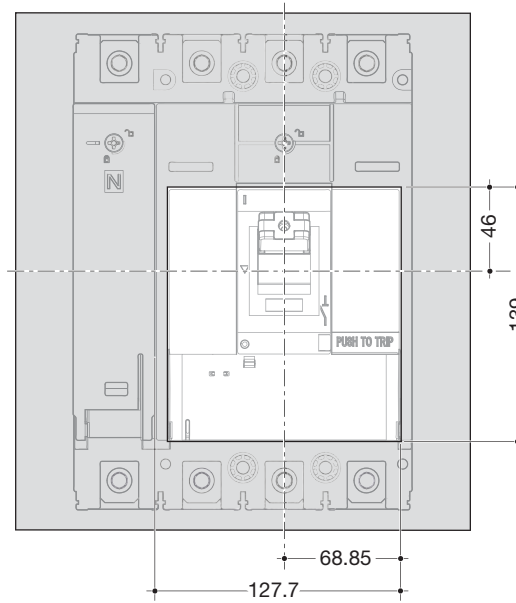

3P

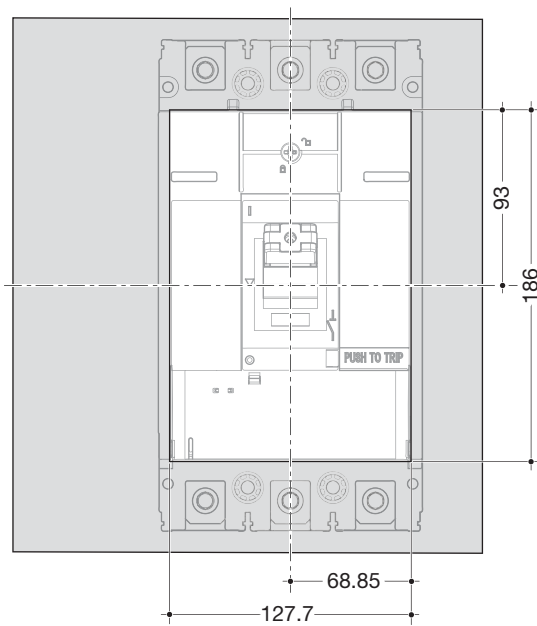

4P

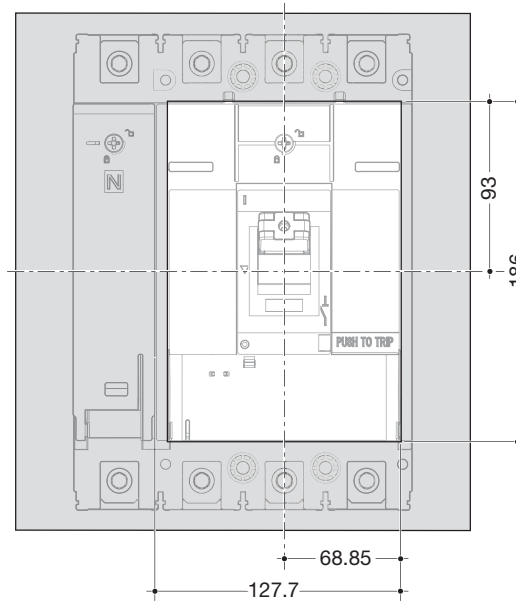

Dimensions and connections

Dimensions in mm

Al/Cu external cable terminals P160

1 wire

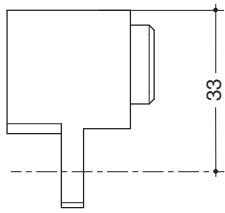

6 wires

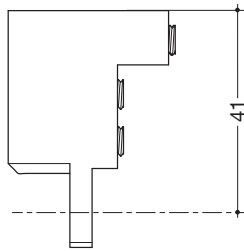

Al/Cu external cable terminals P250

1 wire

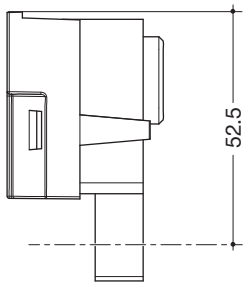

2 wires

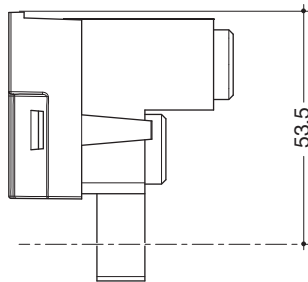

6 wires

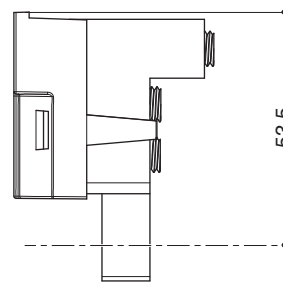

Al/Cu external cable terminals P630

1 wire

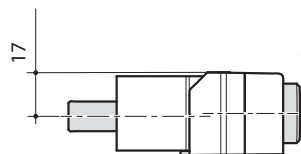

2 wires

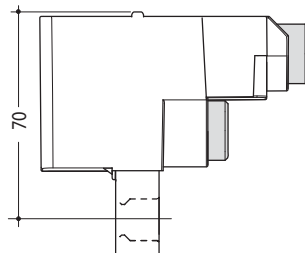

Straight terminal extensions P160

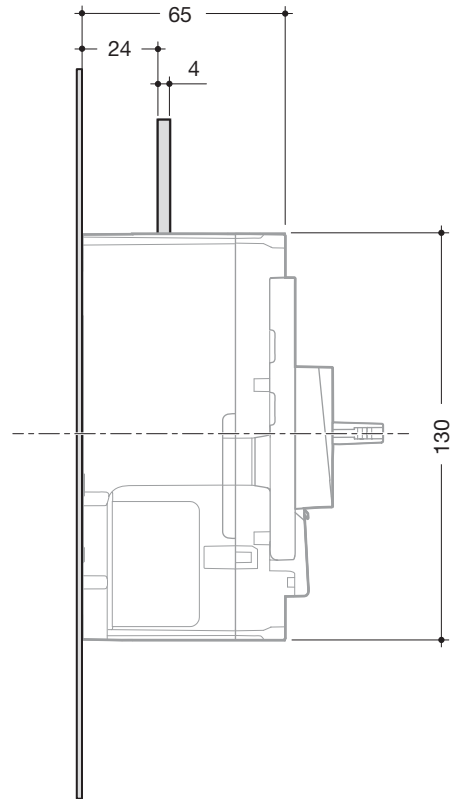
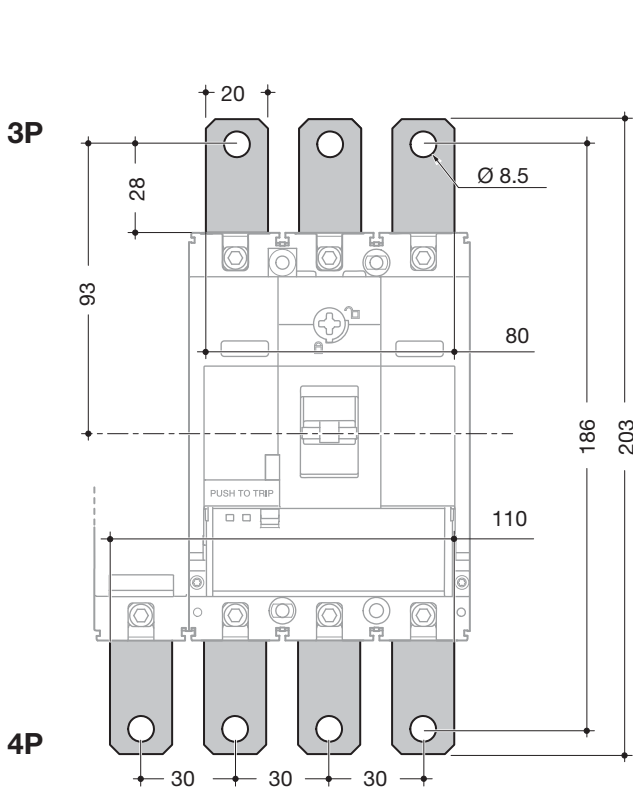

Straight terminal extensions P250

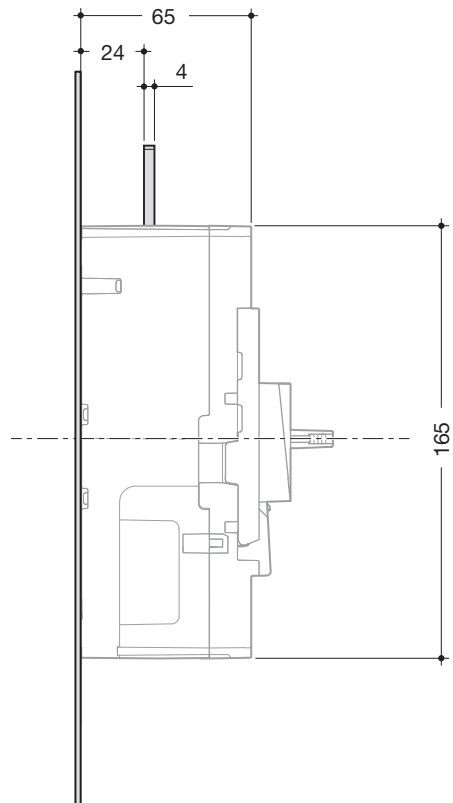
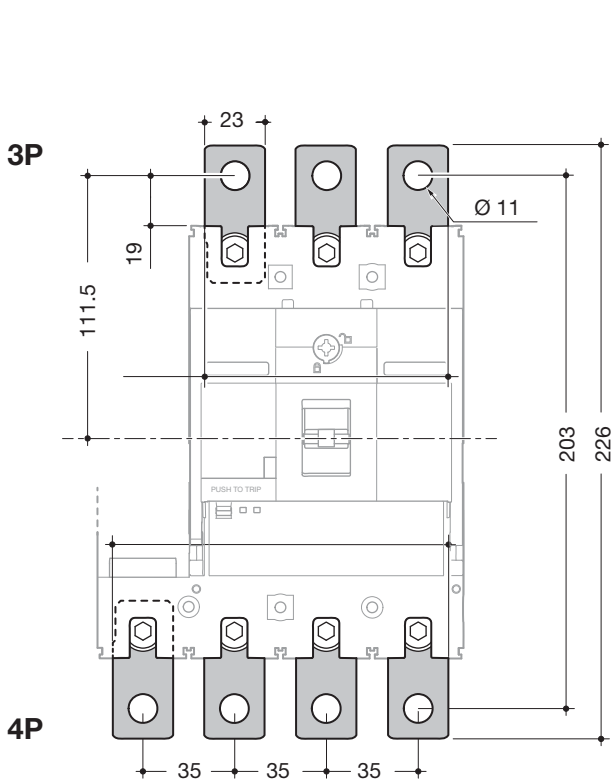

Dimensions in mm

Straight terminal extensions P630

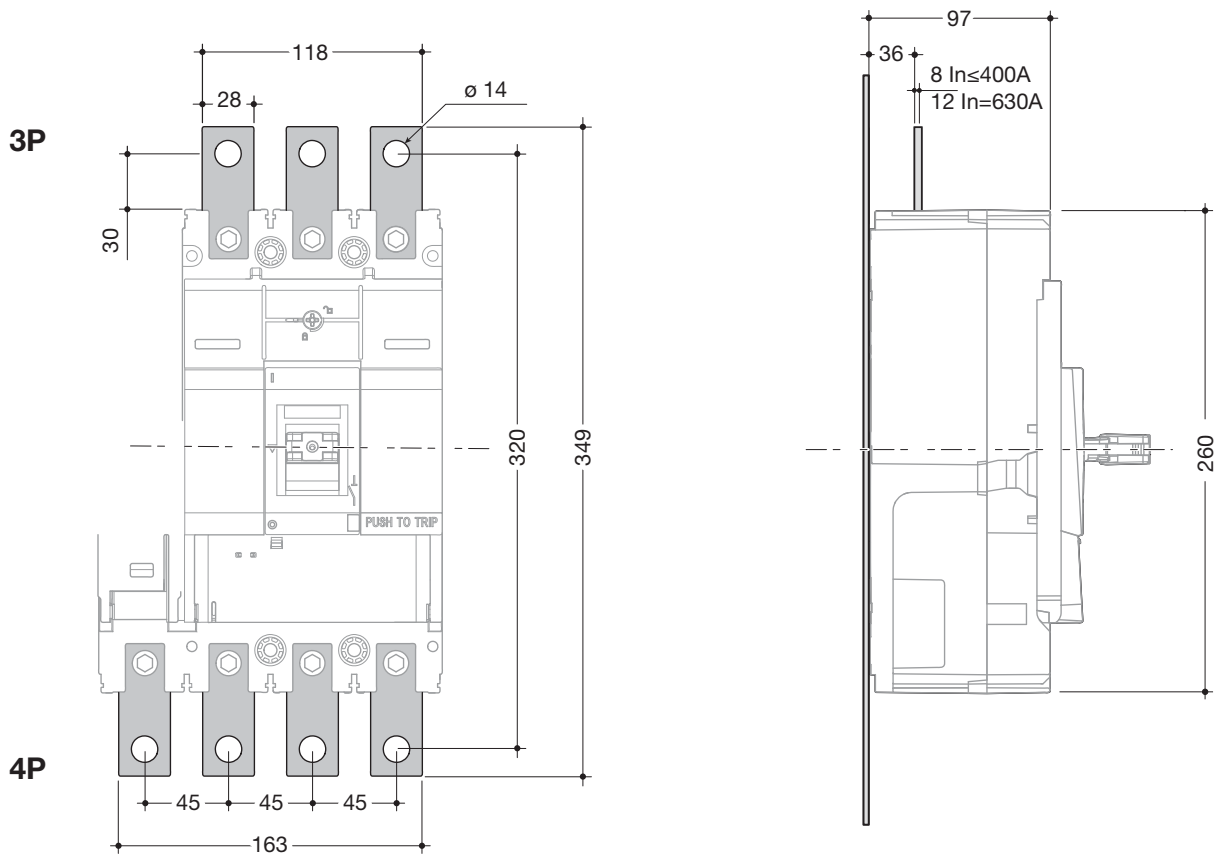

Dimensions in mm

Spreaders P160

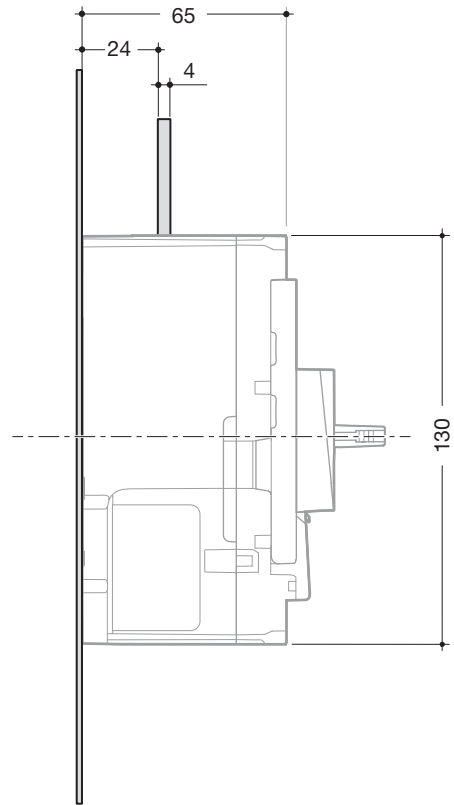
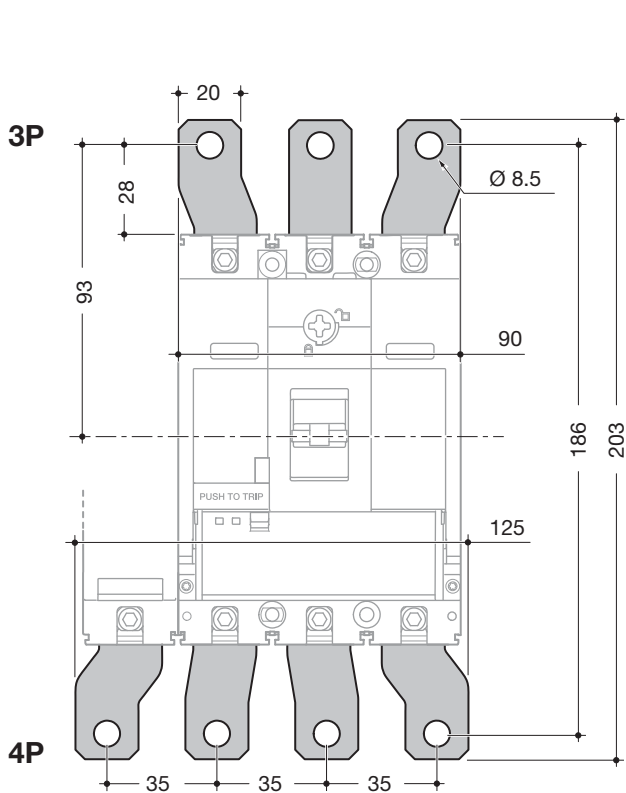

Spreaders P250

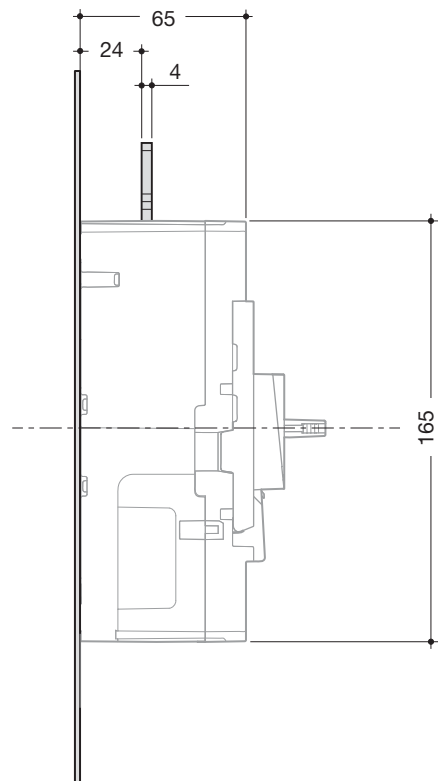
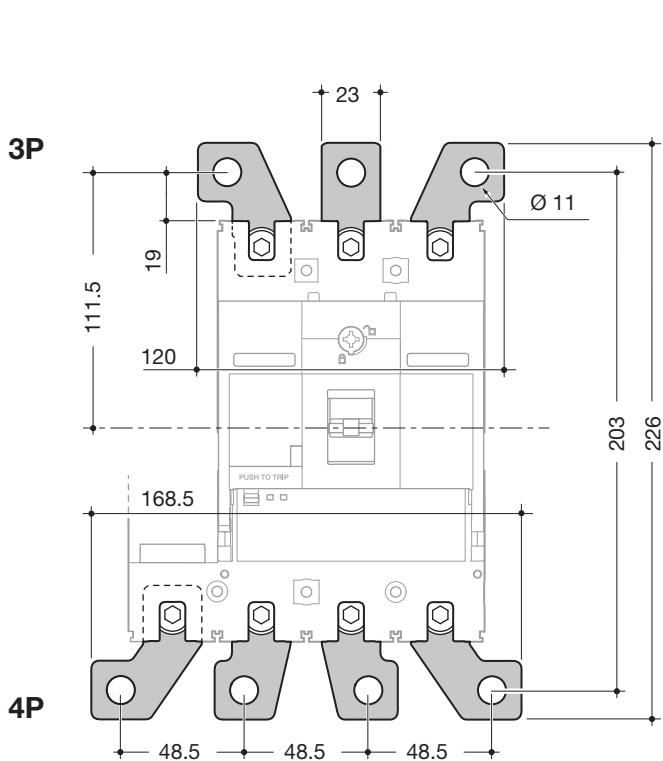

Dimensions in mm

Spreaders P630

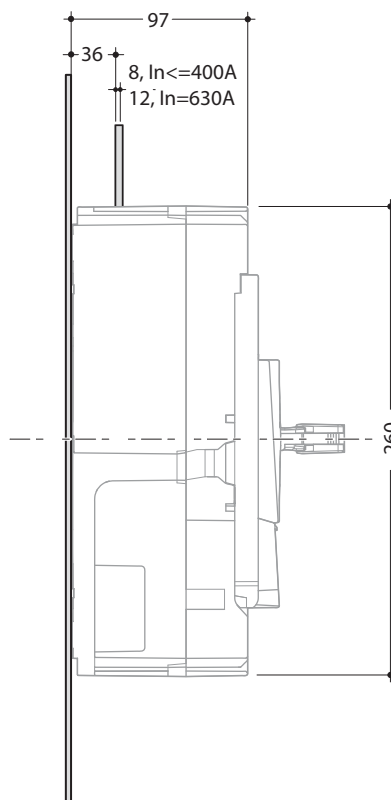
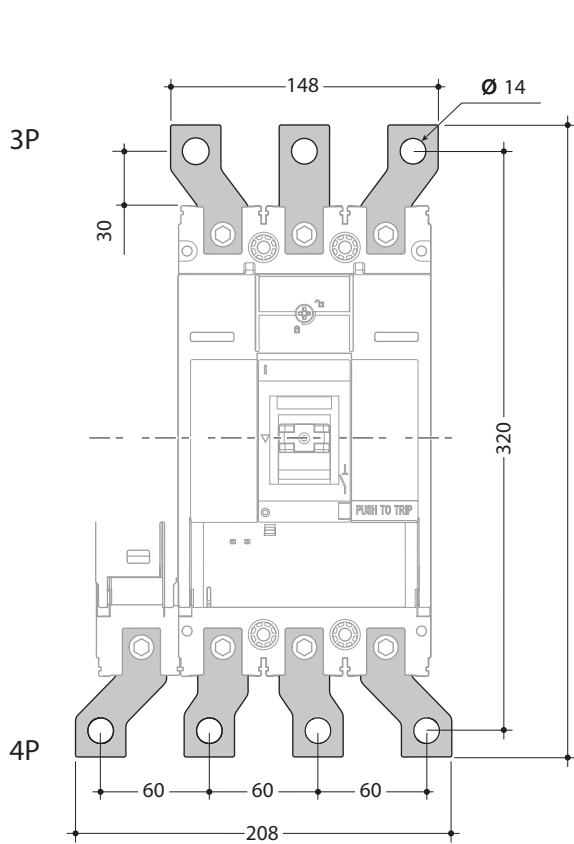

Dimensions in mm

Rear connections P160

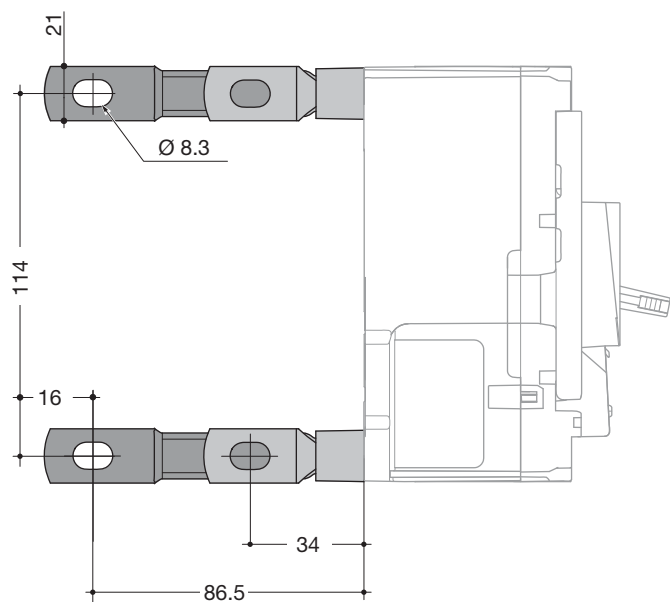

Rear connections P250

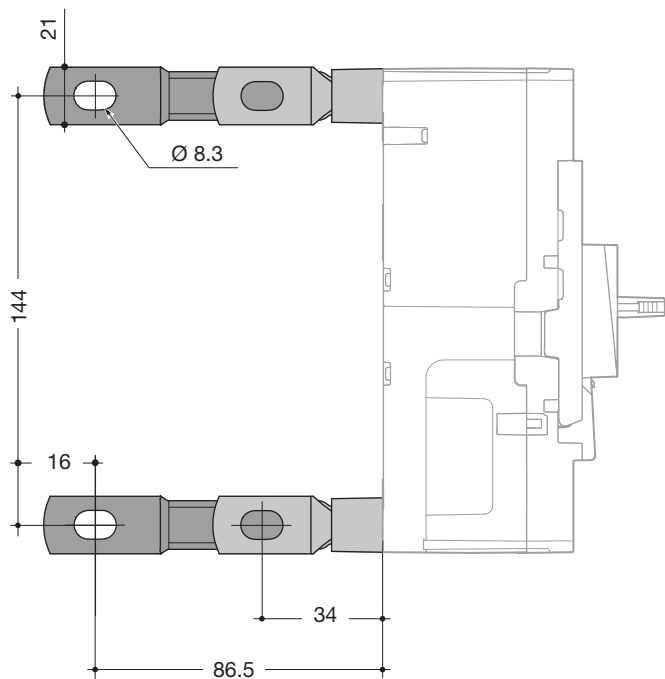

Dimensions in mm

Rear connections P630

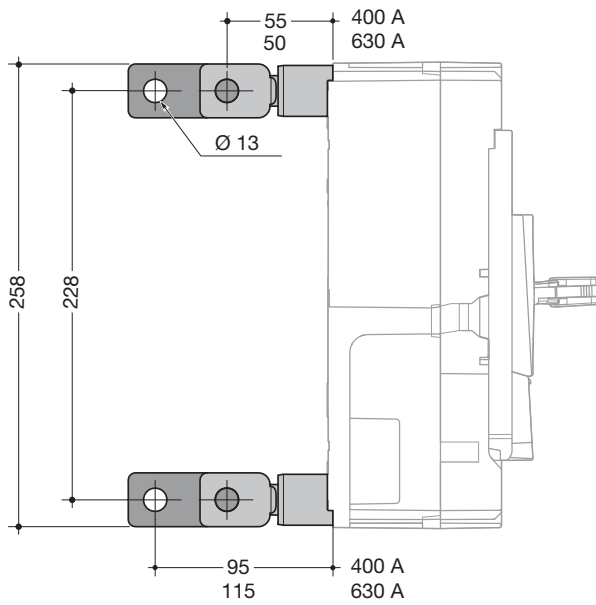

Dimensions in mm

Interphase barriers P160

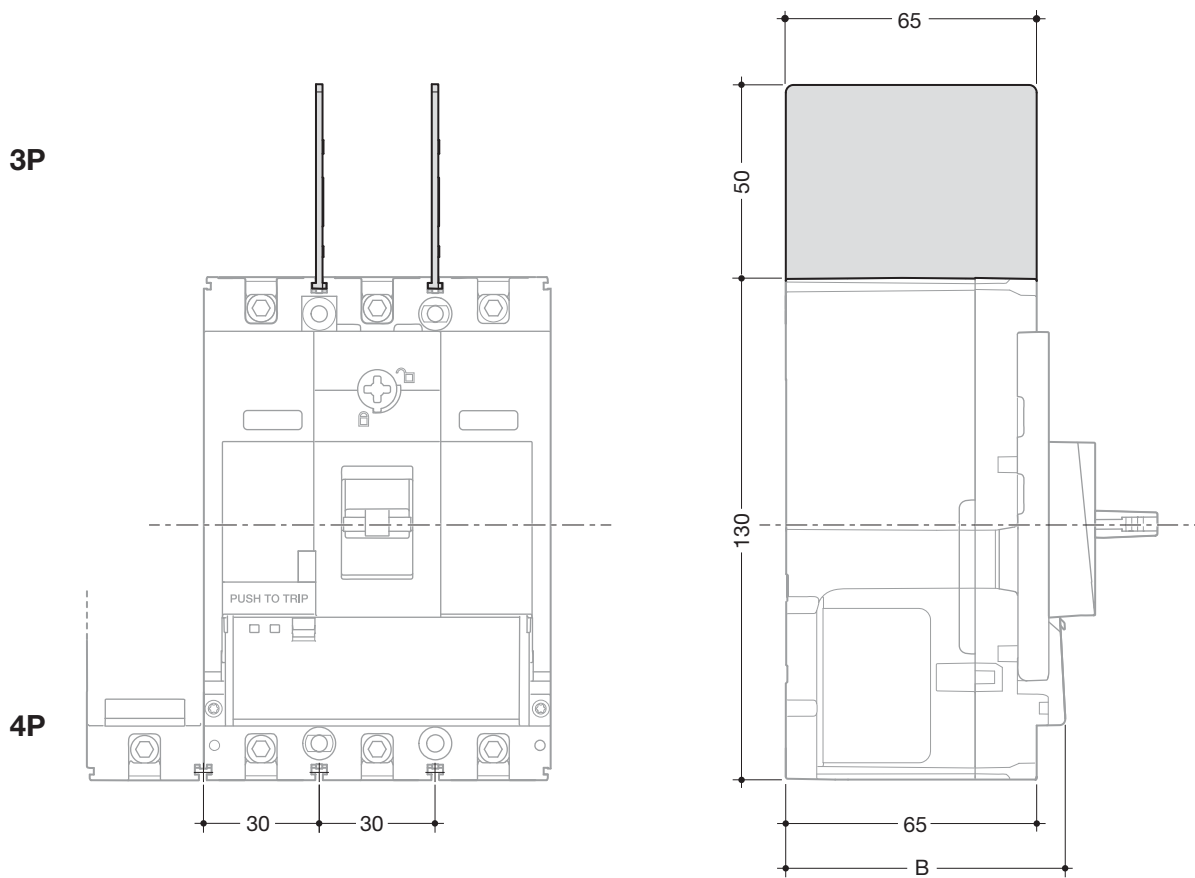

Interphase barriers P250

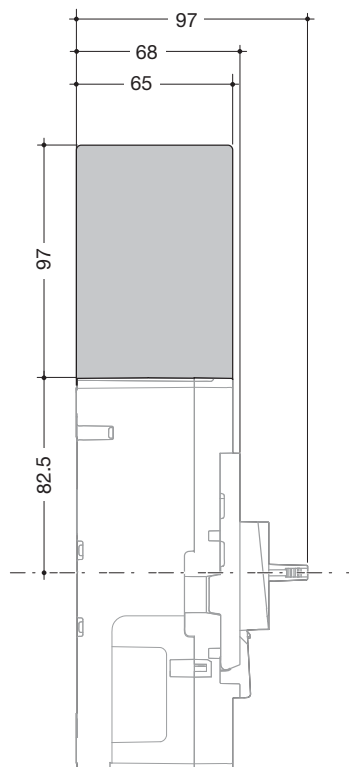

Dimensions in mm

Interphase barriers P630

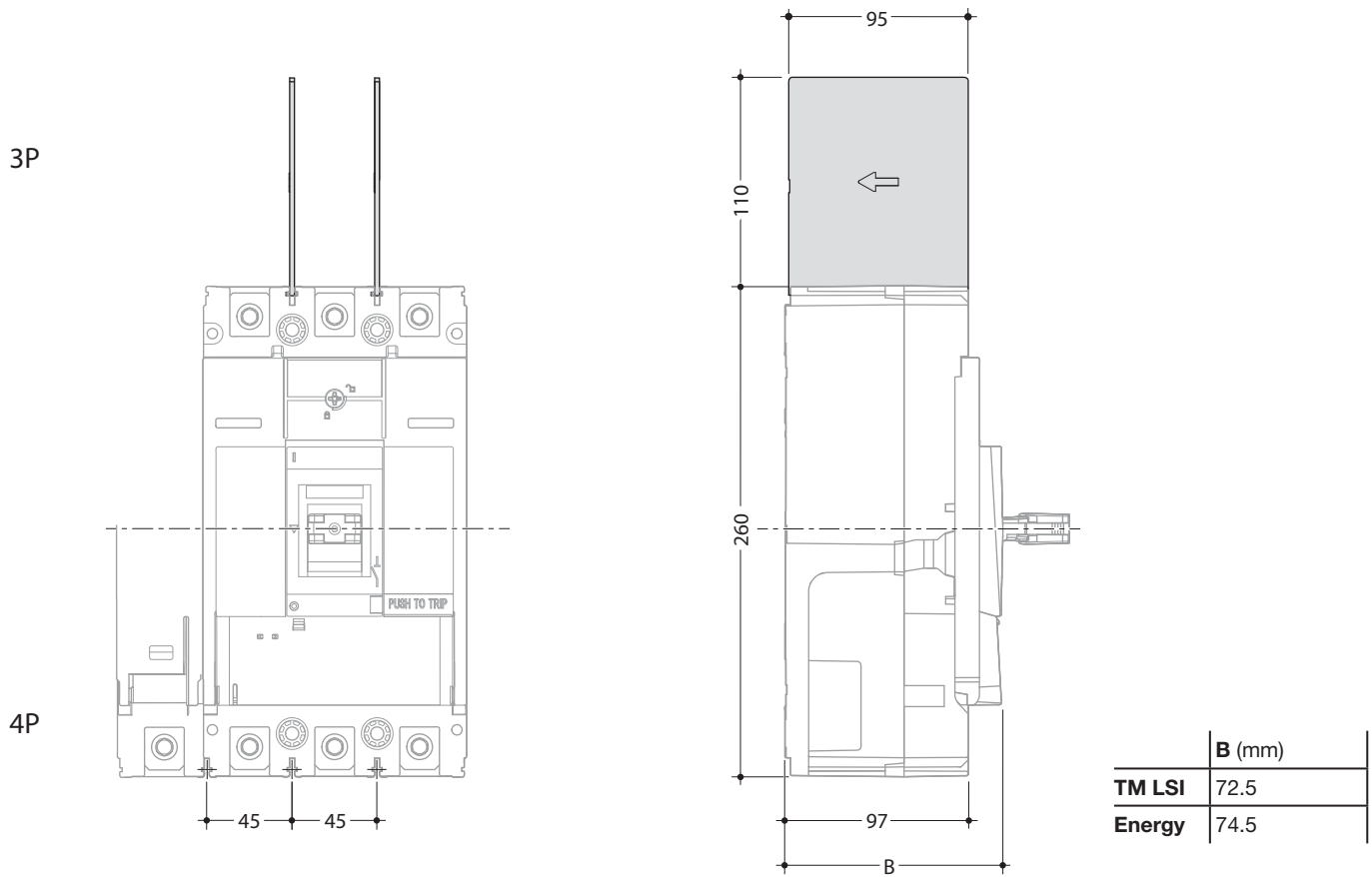

Dimensions in mm

Terminal cover P160

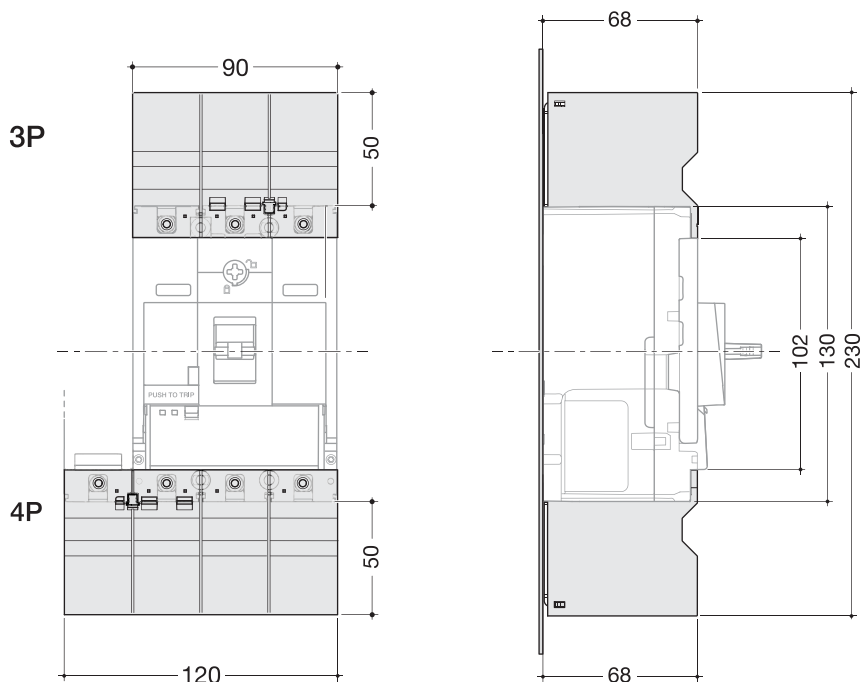

P160 Terminal cover

Terminal cover P250

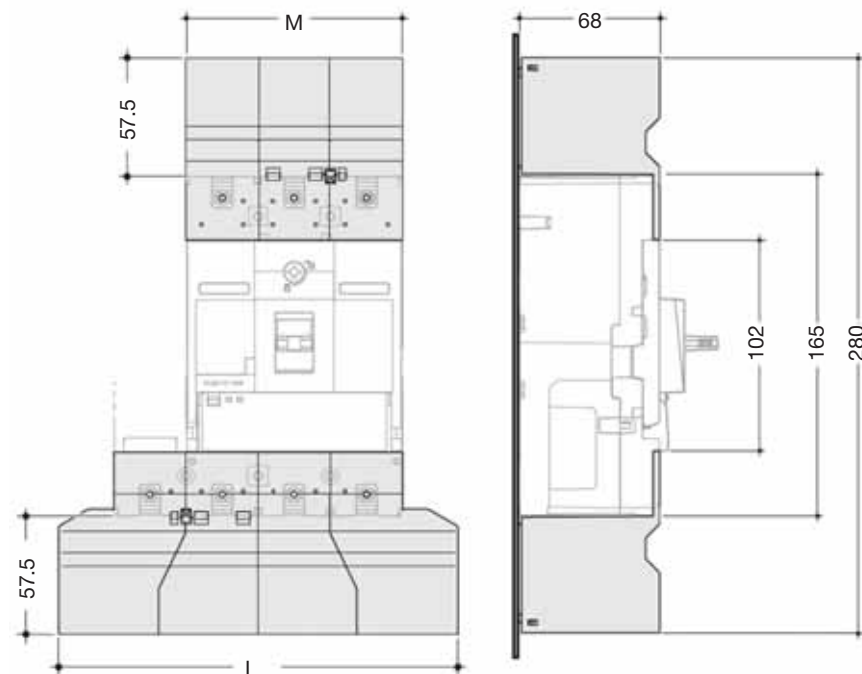

P250 Terminal cover

	L (mm)	M (mm)
3P	145.5	105
4P	193.5	140

Dimensions and connections

Terminal cover P630

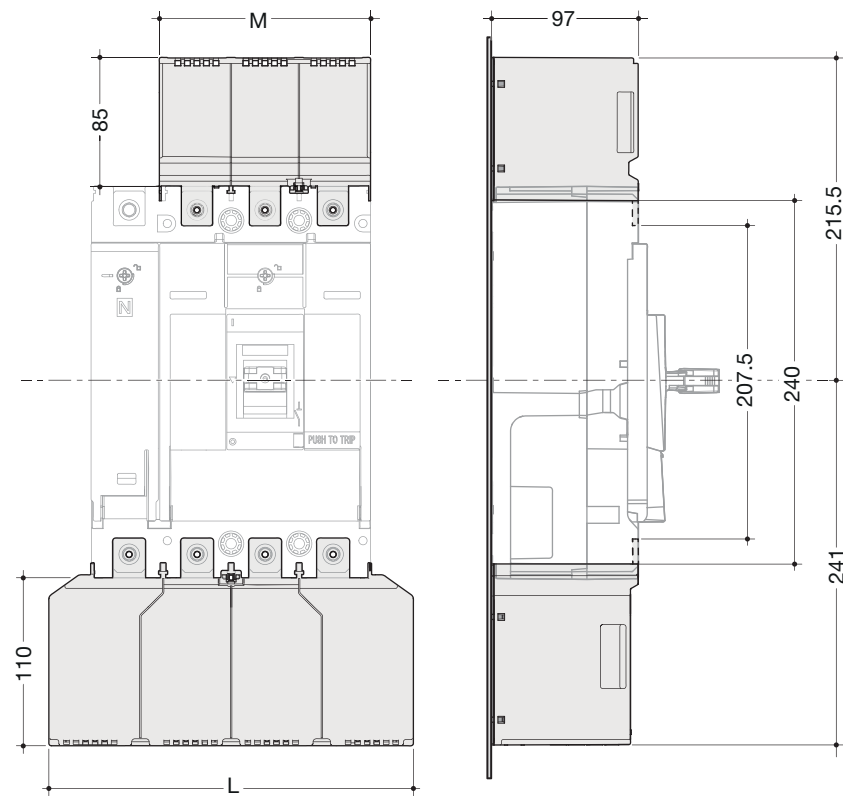

P630 Terminal cover

Panel display

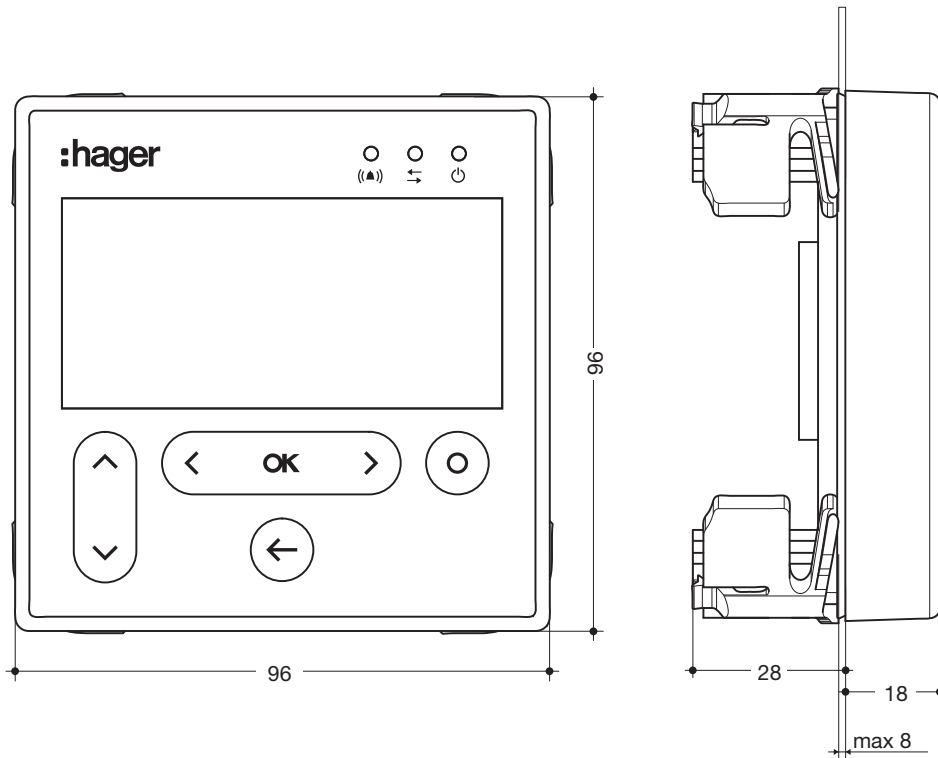

Cut-out

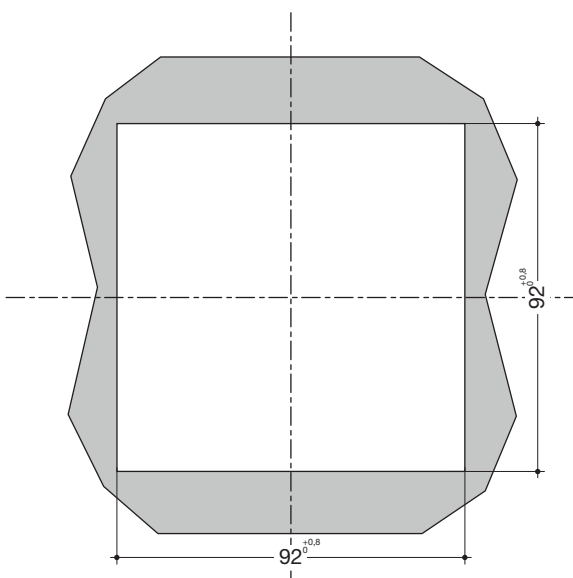

Dimensions in mm

Technical Characteristics

Page

01 Time Current Characteristics, Earth Fault Loop Impedance Data	148
02 Let-Through Energy, Peak Current Cut Off Characteristics	151
03 Electronic Trip Versions	153

Time current characteristics

P160 TM SP devices

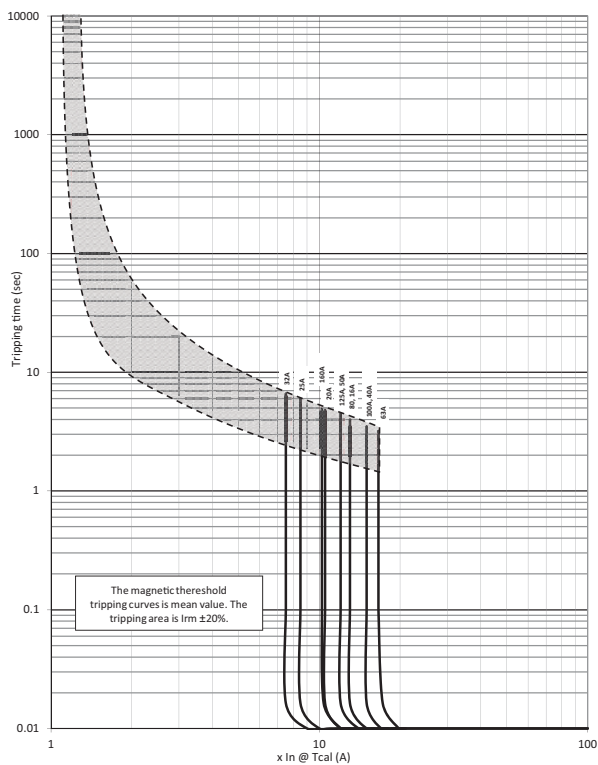

Earth Fault Loop Impedance Data BS 7671: 2018

Disconnection time 0.1s to 1s				
Device rating (A)	Instantaneous trip (xIn)	Instantaneous trip (A)	add 20% tolerance (I _a)	Z _s = 230 x C _{min} / I _a Ω
16	13.1	210.0	252.0	0.87
20	10.5	210.0	252.0	0.87
25	8.4	210.0	252.0	0.87
32	7.5	240.0	288.0	0.76
40	15.0	600.0	720.0	0.30
50	12.0	600.0	720.0	0.30
63	16.6	1045.8	1255.0	0.17
80	13.1	1048.0	1257.6	0.17
100	15.4	1540.0	1848.0	0.12
125	12.3	1537.5	1845.0	0.12

Earth Fault Loop Impedance Data BS 7671: 2018

Disconnection time 5s				
Device rating (A)	Instantaneous trip (xIn)	Instantaneous trip (A)	If Magnetic trip add 20% tolerance (I _a)	"Z _s = 230 x C _{min} / I _a Ω"
16	10.0	160.0	N/A	1.37
20	10.0	200.0	N/A	1.09
25	8.5	212.5	255.0	0.86
32	7.5	240.0	288.0	0.91
40	10.0	400.0	N/A	0.55
50	10.0	500.0	N/A	0.44
63	10.0	630.0	N/A	0.35
80	10.0	800.0	N/A	0.27
100	10.0	1000.0	N/A	0.22
125	10.0	1250.0	N/A	0.17

Time current characteristics

P160 TM TP/4P devices

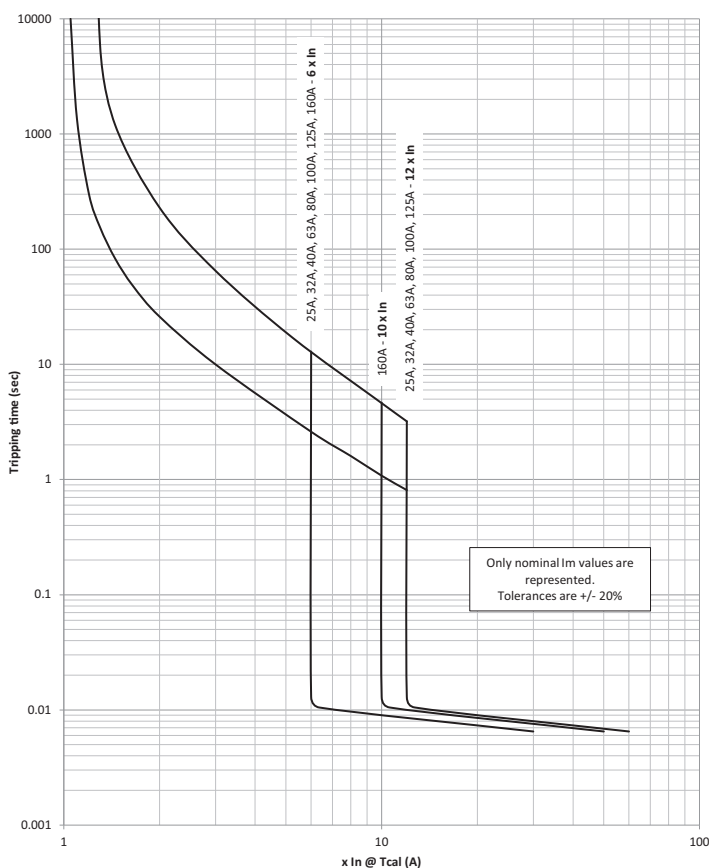

Earth Fault Loop Impedance Data BS 7671 2018

$$Z_s = \frac{230 \times C_{min}}{I_a}$$

Where $I_a = I_n \times I_j \times 1.2$

For 5s disconnection where devices I_j set to x12

$$I_a = I_n \times 10$$

Time current characteristics

P250 TM devices

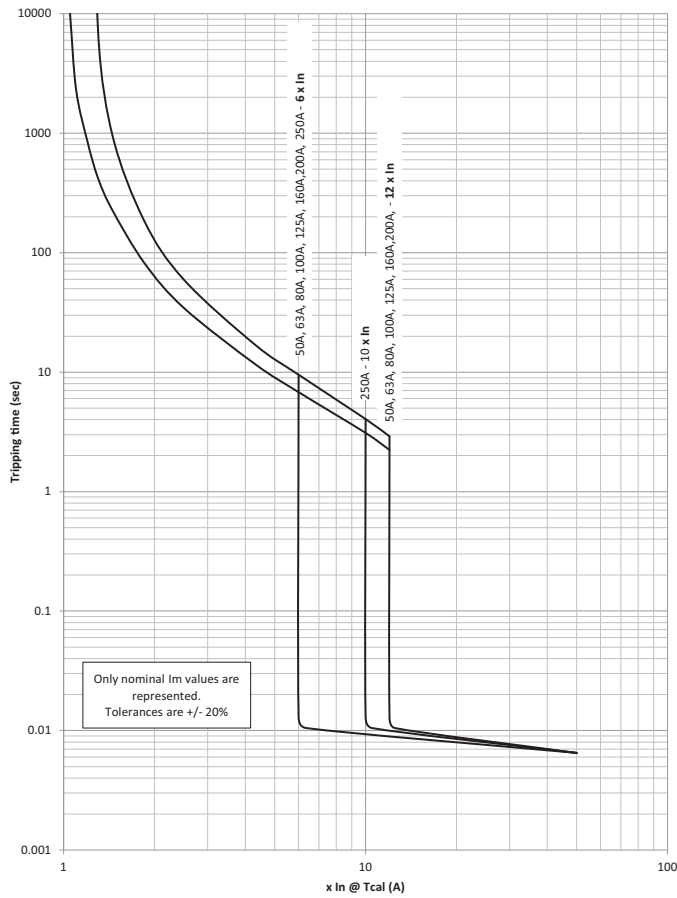

Earth Fault Loop Impedance Data BS 7671 2018

$$Z_s = \frac{230 \times C_{min}}{I_a}$$

Where $I_a = I_n \times I_f \times 1.2$

Where $I_f \geq 10$

$$I_a = I_n \times 10$$

P160 MAG (ICB)

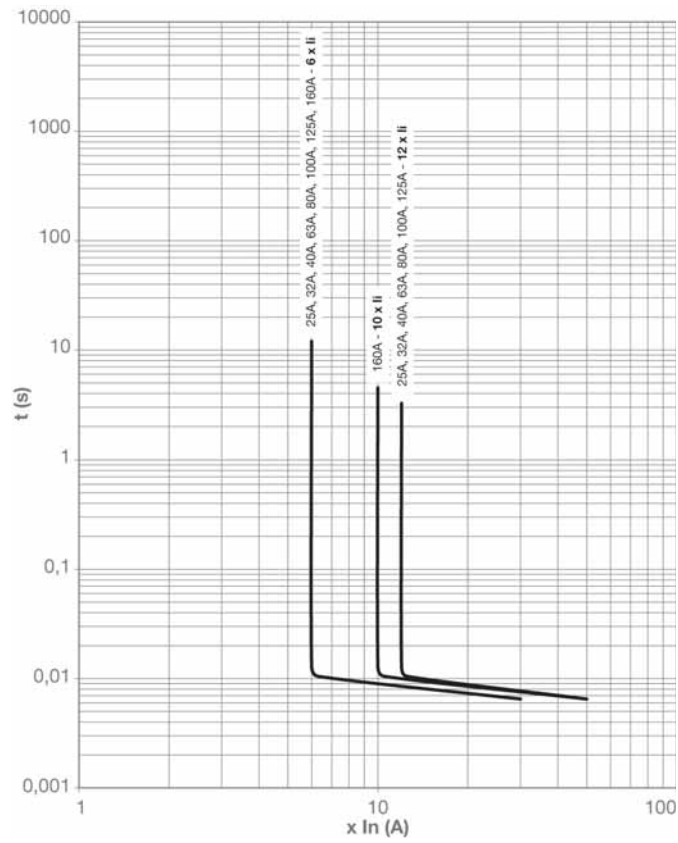

P250 MAG (ICB)

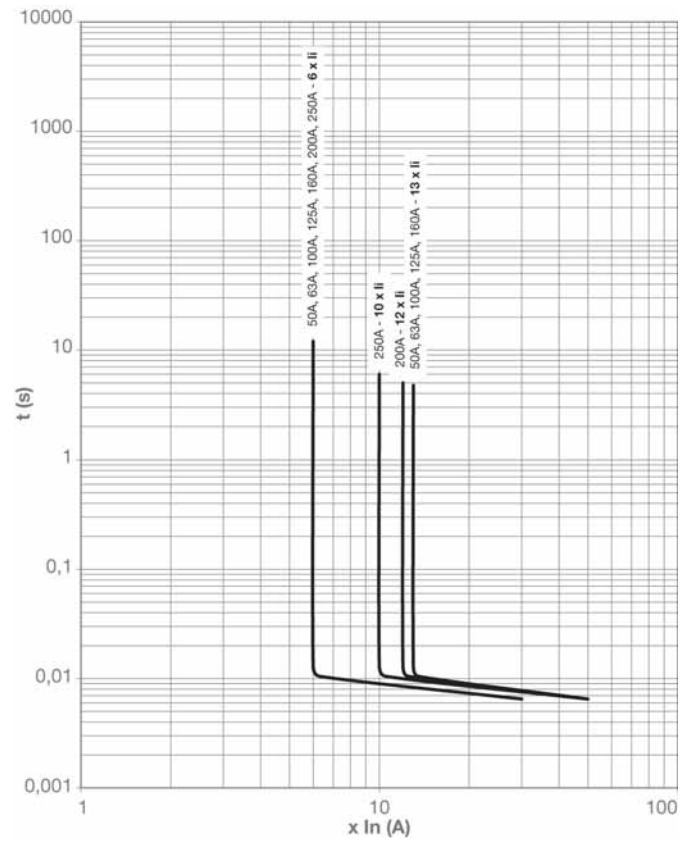

Energy limiting characteristics

P160 TM SP

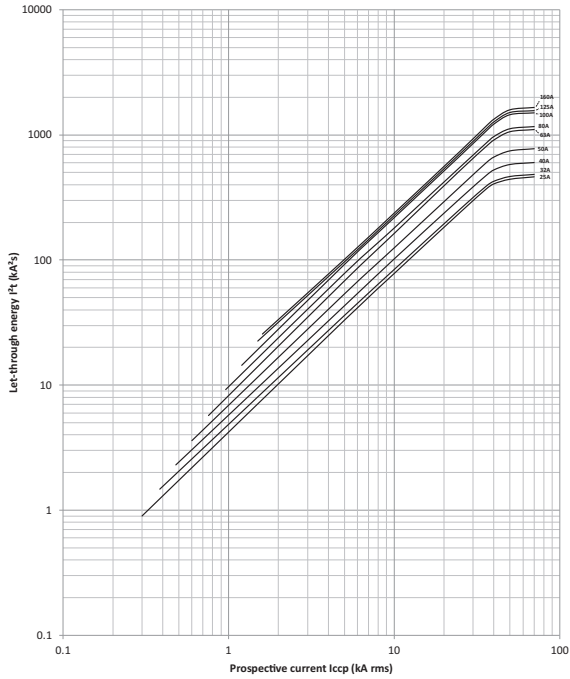

P160 TM & MAG TP 4P

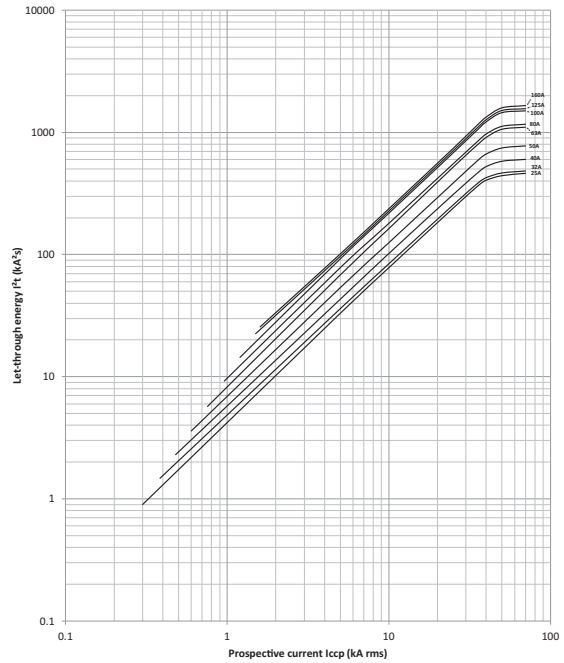

Current limiting characteristics

P160 TM SP

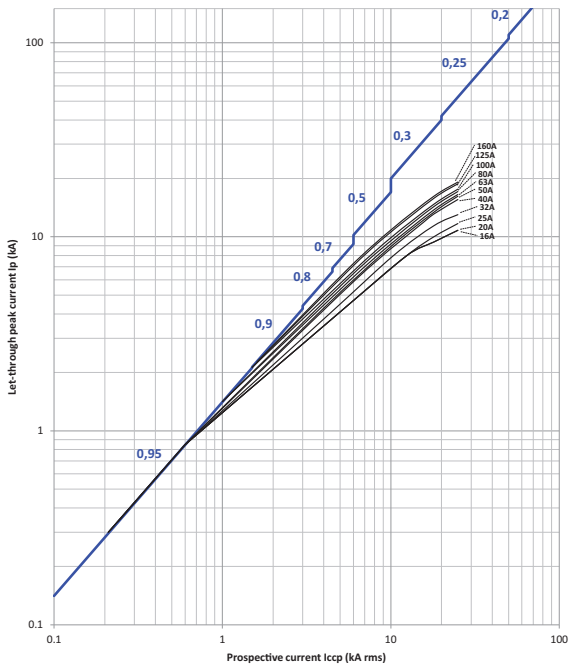

P160 TM & MAG TP 4P

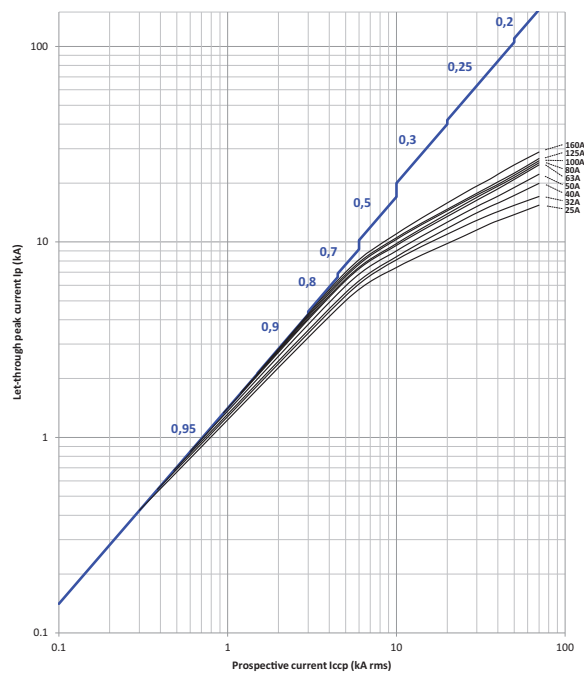

Technical Characteristics

Energy limiting characteristics

P250 TM & MAG TP 4P

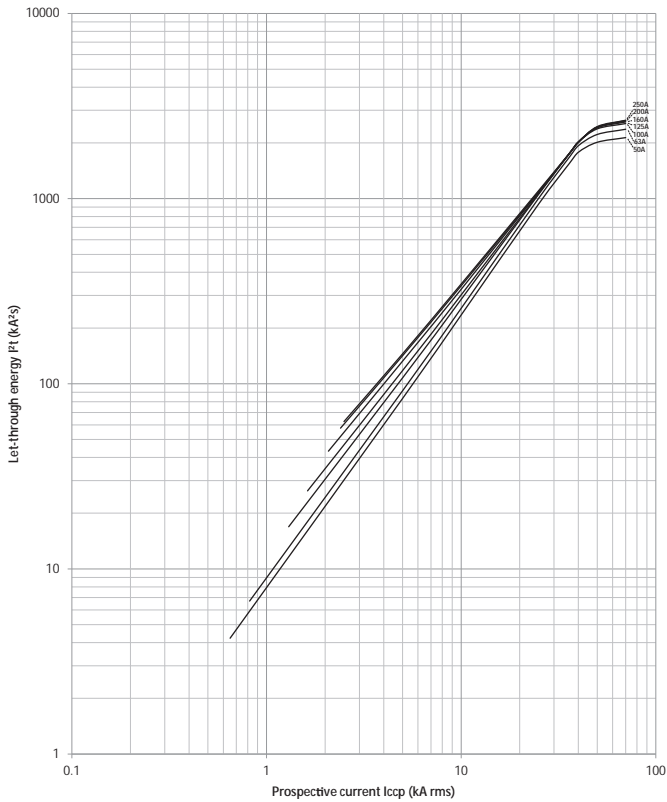

Current limiting characteristics

P250 TM & MAG TP 4P

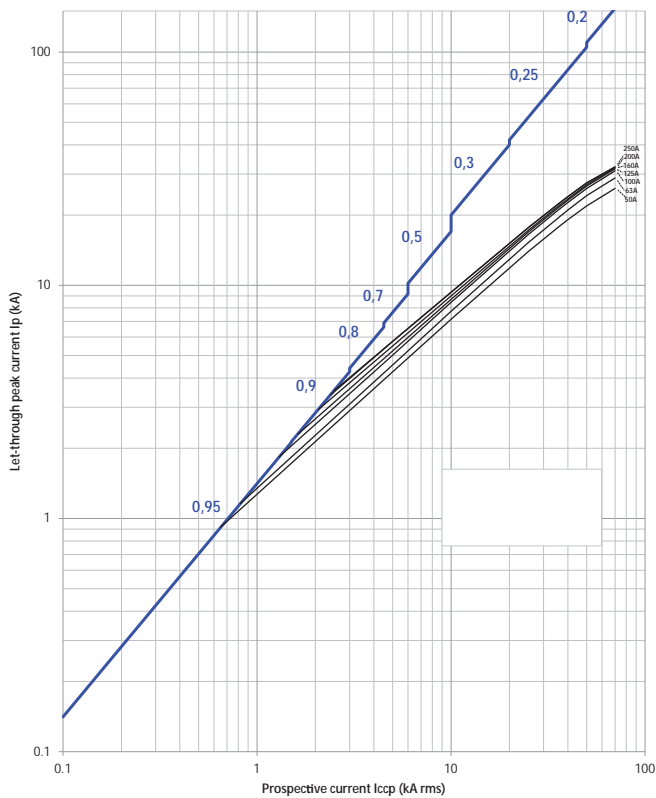

Tripping tolerance of electronic trip units

Time / current characteristic curves are not given for electronic devices due to the wide adjustments available on these devices.

Tolerances limits for tripping curves of electronic trip units are not described on tripping curve drawings.

Both following diagrams give the tolerance to take in account on further LSnl, LSI, LSIg and Energy tripping curve drawings.

Tolerance limits of LSnl, LSI, LSIg and Energy tripping curves

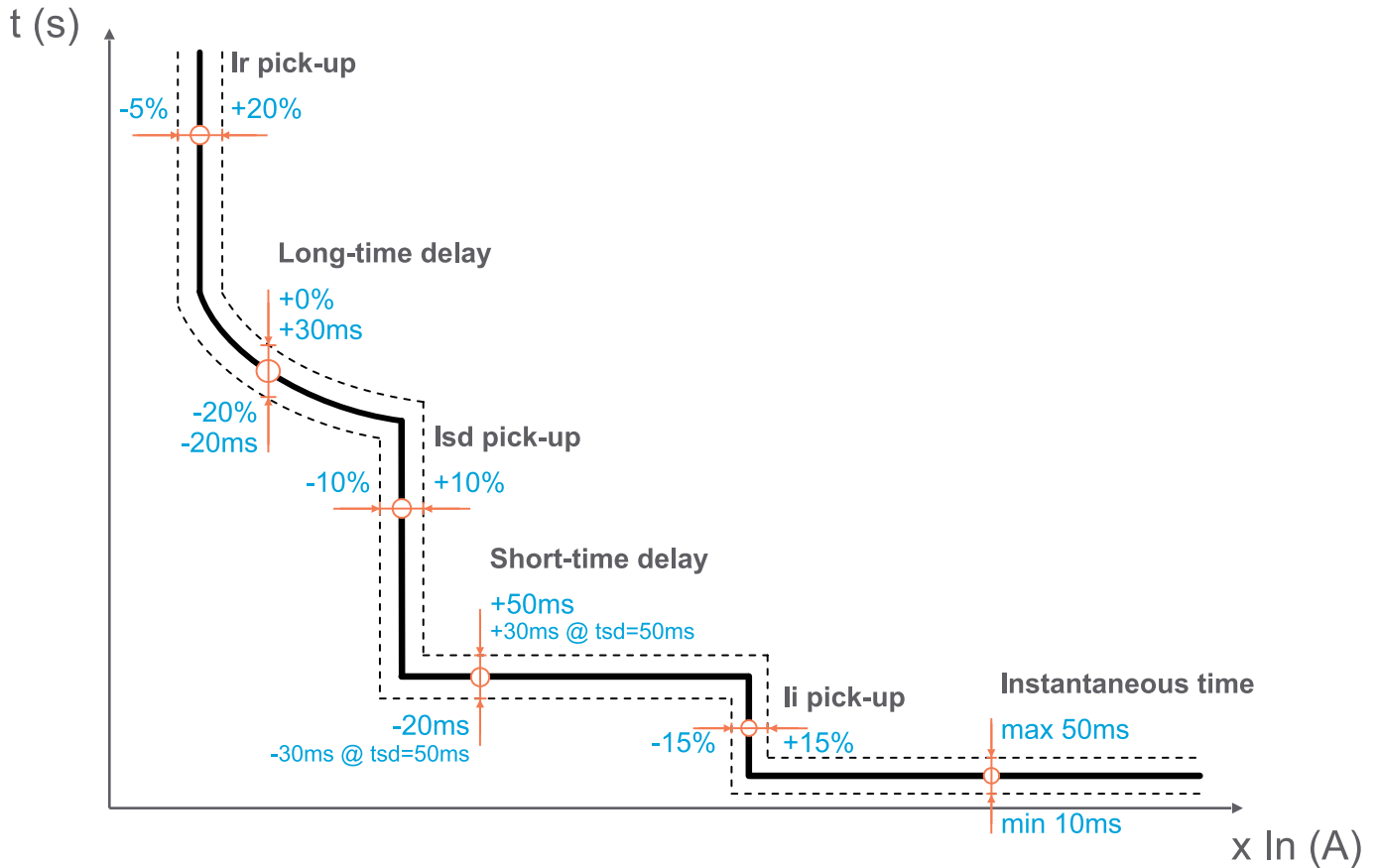

Tolerance limits of G characteristic of Energy trip unit

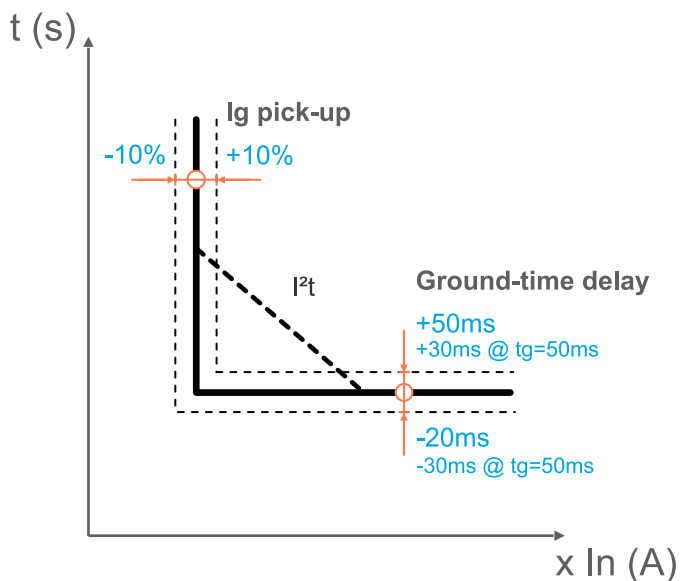

Energy limiting characteristics

P160 Electronic Trip Units - LSnl

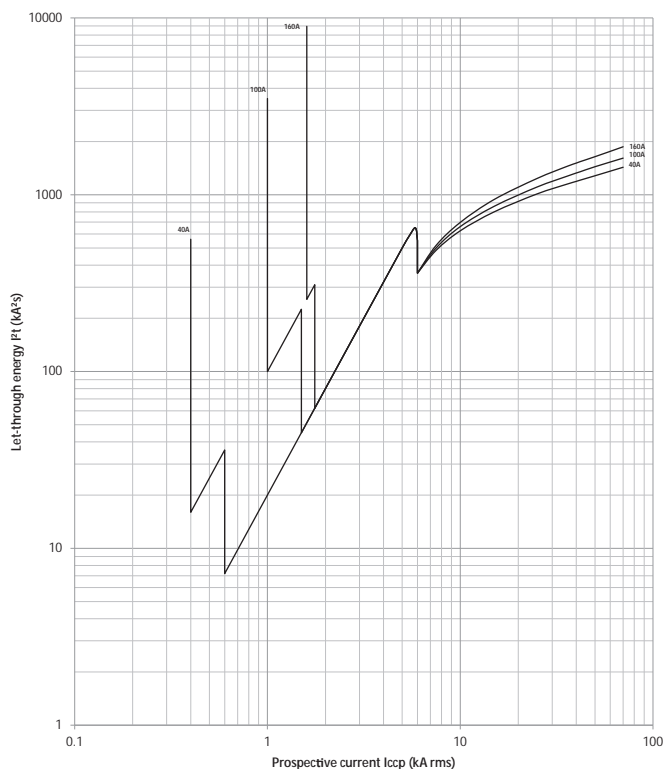

P160 Electronic Trip Units - LSI / Energy

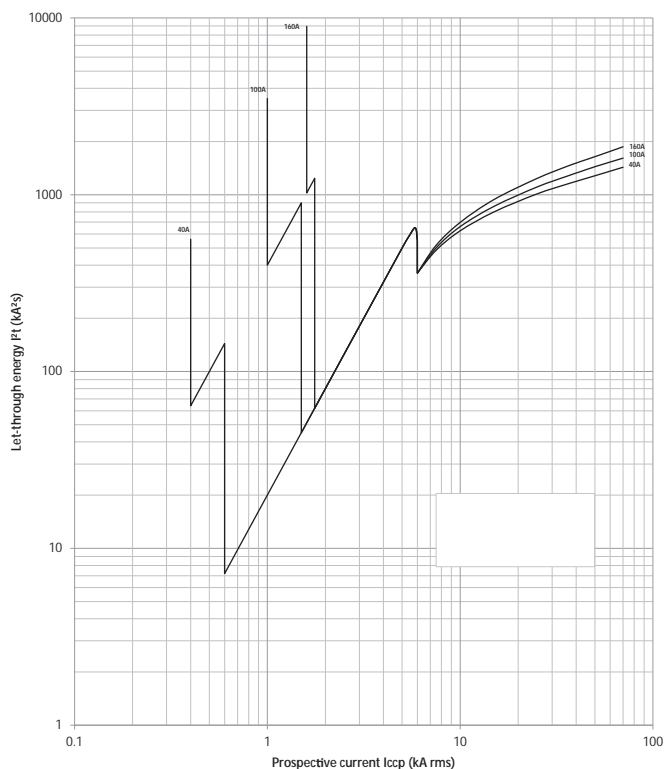

Current limiting characteristics

P160 Electronic Trip Units - LSnl / LSI / Energy

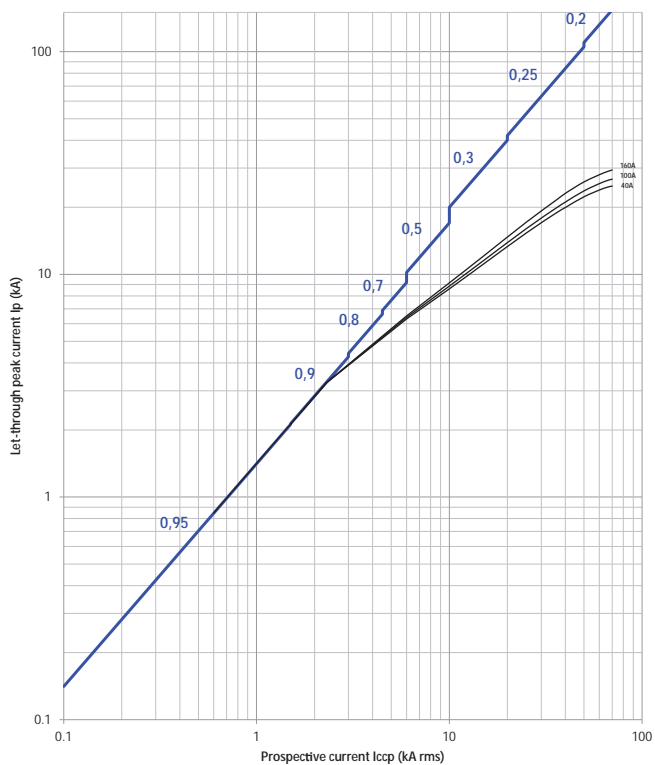

Energy limiting characteristics

P250 Electronic Trip Units - LSnl

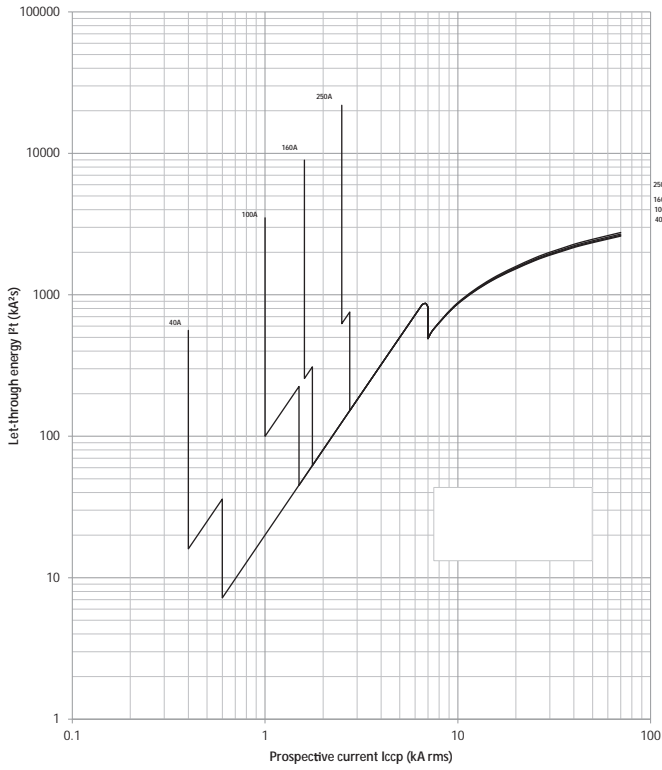

P250 Electronic Trip Units - LSI / LSIg / Energy

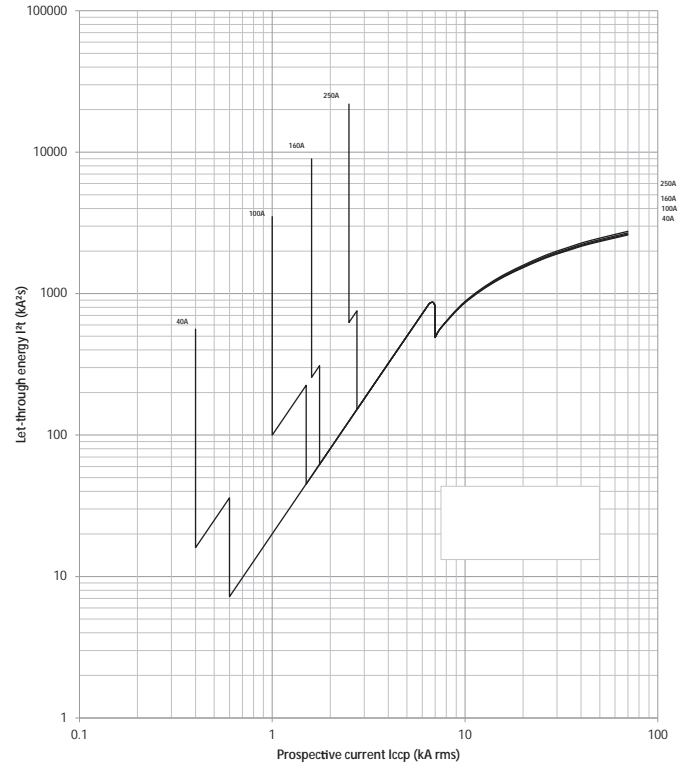

Current limiting characteristics

P250 Electronic Trip Units - LSnl / LSIg / Energy

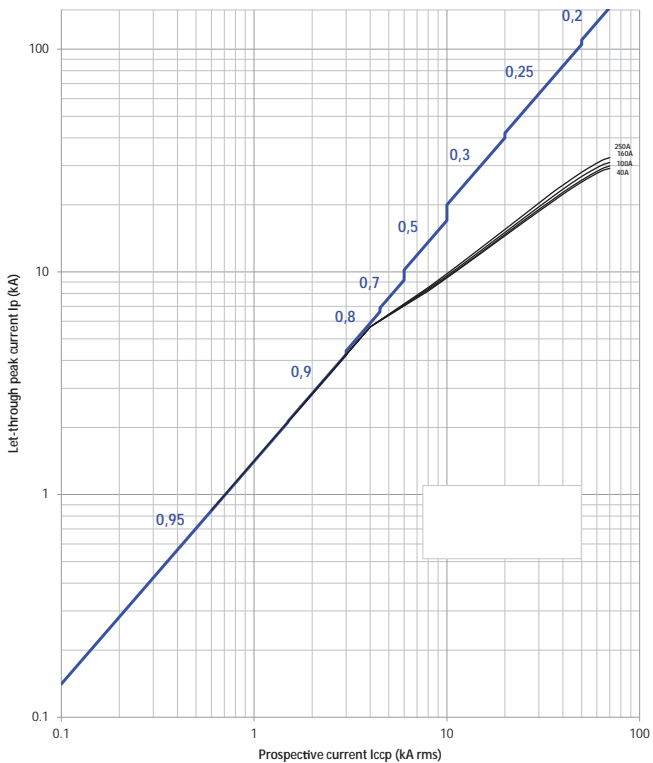

Energy limiting characteristics

P630 Electronic Trip Units - LSI / LSIG / Energy

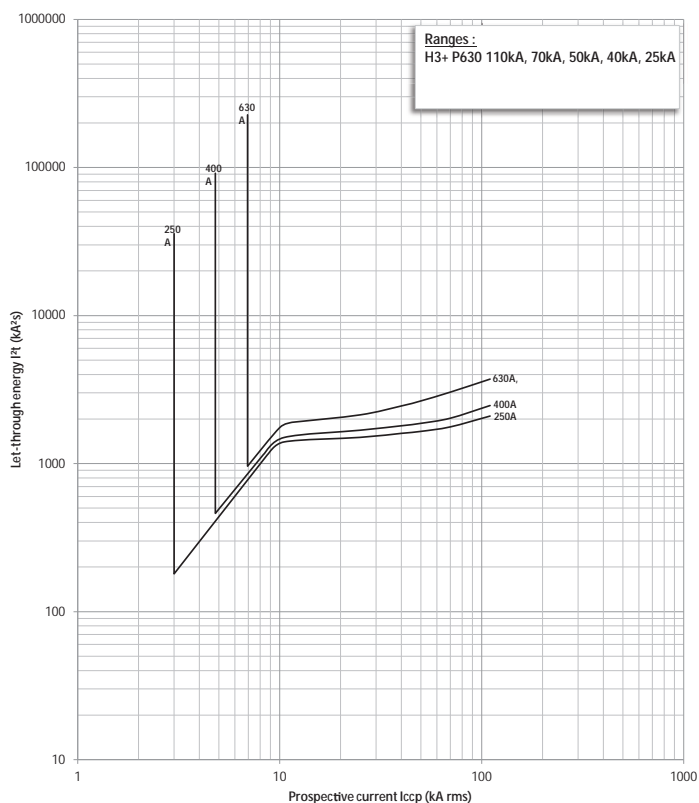

Current limiting characteristics

P630 Electronic Trip Units - LSI / LSIG / Energy

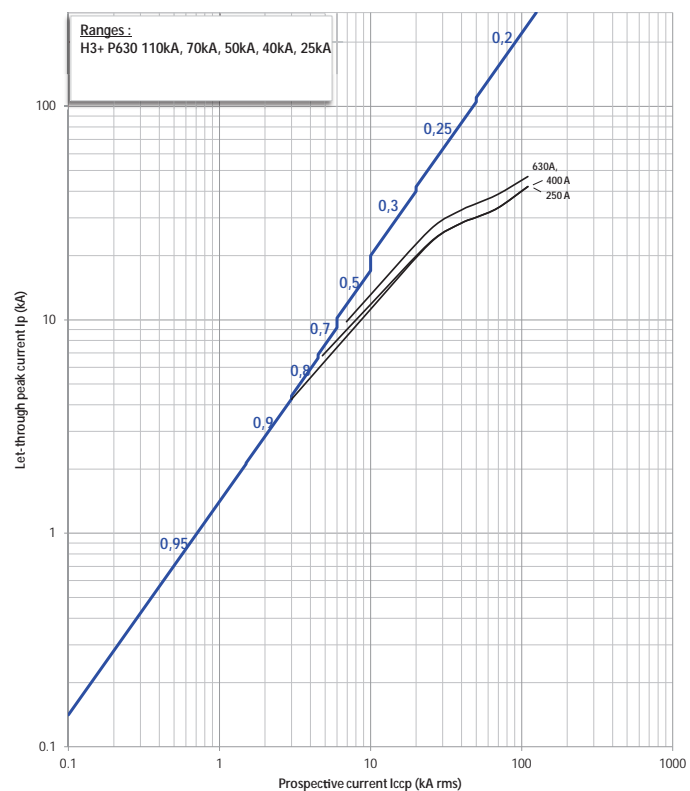

Glossary

Adjustment dial

Knob for a manual adjustment of the circuit breaker settings.

ACP

AX/AL communication port. Dedicated terminal to connect the AX/AL Energy device.

AL

Alarm switch

AX

Auxiliary switch

Breaking capacity

The value of prospective current that a switching device is capable of breaking at a stated voltage under prescribed conditions of use and behaviour. Reference is generally made to the rated ultimate short-circuit breaking capacity (Icu) and the service breaking capacity (Ics).

Cascading

Also called coordination, cascading takes into account the current-limiting capacity of a circuit breaker. There is a possibility to install downstream circuit breakers with lower Icu performance levels. The upstream circuit breaker reduces any high short-circuit currents. This makes it possible to install downstream circuit breakers with breaking capacities less than the prospective short-circuit current at their point of installation. The main advantage of cascading is to reduce the overall cost of switchgear, as the current is limited throughout the circuit downstream of the limiting circuit breaker. Cascading applies to all the devices fitted downstream.

CIP

Communication Interface Port. Terminal to connect the COM Module or the Panel display.

Circuit breaker

General term for Moulded Case Circuit Breaker or MCCB.

Delayed undervoltage release

Undervoltage release with a given delayed tripping time.

Delayed UVR

Delayed undervoltage release

Direct rotary handle

Optional handle with the same three positions I (ON), O (OFF) and TRIPPED as the MCCB handle. It maintains suitability for isolation and offers optional locking using a keylock or a padlock.

Discrimination

Also called selectivity, discrimination is ensured between upstream and downstream circuit breakers if, when a fault occurs, only the circuit breaker placed immediately upstream

of the fault trips. Discrimination is the key to ensure the continuity of service of an installation.

Energy

Name of h3+ circuit breakers fitted with measurement, alarm and communication features.

Energy trip unit

Electronic trip unit with adjustable L, S, I and G. Also fitted with measurement, alarm and communication features.

International Protection Marking (IP)

Defines protection of circuit breakers against the penetration of solid objects and liquids, using two digits according to standard IEC 60259. Each digit corresponds to a level of protection, where 0 indicates no protection.

First digit (0 to 6): protection against penetration of solid foreign objects.

1 corresponds to protection against objects with a diameter > 50 mm, 6 corresponds to total protection against dust.

Second digit (0 to 9): protection against penetration of liquids (water).

1 corresponds to protection against falling drops of water (condensation), 9 corresponds to continuous immersion.

Low level auxiliary contact

The low internal impedance of these contacts allows to switch low current levels under low voltages.

LSnl trip unit

Electronic trip unit with adjustable Ir and I_{sd} and with fixed tr and tsd. Instantaneous I_i is fixed.

LSI trip unit

Electronic trip unit with adjustable L, S and I.

LSIG trip unit

Electronic trip unit with adjustable L, S, I and with fixed G.

MAG trip unit

Magnetic trip unit

MCCB

Moulded Case Circuit Breaker

MIP

Maintenance Interface Port

Motor operator

Accessory used to remotely open, close and recharge the MCCB.

OAC

Optional Alarm Contact (digital output contact).

On door rotary handle

Rotary handle with an extended shaft to control MCCBs from the door of switchboards. It has the same characteristics as

direct rotary handles. It offers multiple locking possibilities using a keylock, a padlock or a door interlock.

Pitch

Distance between connection terminals of the circuit breakers.

Pollution degree

Conventional number based on the amount of conductive or hygroscopic dust, ionized gas or salt and on the relative humidity and its frequency of occurrence, resulting in hygroscopic absorption or condensation of moisture leading to reduction in dielectric strength and/or surface resistivity. h3+ circuit breakers are degree 3 according to Standard IEC 60947-1 (conductive pollution occurs, or dry, non-conductive pollution occurs which becomes conductive due to condensation).

PTA

Pre-trip alarm. Also name of associated output contact.

Rated service short-circuit breaking capacity (Ics)

Expressed as a percentage of Icu, it provides an indication of the robustness of the device under severe conditions. It is confirmed by a test sequence O - t - CO - t - CO at Ics. It is followed by a test to prove that the device operates correctly at its rated current and the protection system suffers from no damage.

Rated ultimate short-circuit breaking capacity (Icu)

Expressed in kA, it indicates the maximum breaking capacity of the circuit breaker. It is confirmed by a test sequence O - t - CO (according to IEC 60947-2) at Icu, followed by a test to prove that the circuit is correctly isolated. This test ensures user safety.

Safety clearance

When installing a circuit breaker, minimum distances (safety clearances) must be maintained between the device and panels, bars and other protection systems installed nearby. These distances, which depend on the ultimate breaking capacity, are defined by tests according to standard IEC 60947-2.

Shunt trip release

Release operating when supplied with current. It makes circuit breaker opening when it receives a pulse-type or maintained command.

TM trip unit

Thermal magnetic trip unit

Trip unit

Integrated underneath the handle of the circuit breaker, this part is responsible of tripping the circuit breaker depending on the protection parameters that the user sets.

Undervoltage release

Release operating when the supply voltage drops below the given level.

Withdrawable circuit breaker

Circuit breaker which can easily be disconnected from the installation thanks to a draw-out system.

ZSI

Zone Selective Interlocking



Hager Ltd.

Unit M2
Furry Park Industrial Estate
Swords Road
Santry
Dublin D09 NY19
Ireland

Tel: 0818 551502

Fax: 0818 551503

Technical Support: +353 1 5180844

hager.ie

customer.service@hager.ie

technical.service@hager.ie